

NOTES:

1. IMPEDANCE: 75 OHM
2. FREQUENCY RANGE: DC - 6 GHz
3. VSWR: 1.1 MAX
4. DIELECTRIC WITHSTANDING VOLTAGE: 1500 VRMS, MIN.
5. CRIMPED FERRULE
HEX.CRIMP SIZE 0.278"
6. CRIMPED CONTACT PIN
HEX.CRIMP SIZE 0.041" OR 0.042"

112957-11		REVISIONS			
DRAWING NO.	REV	DESCRIPTION	DATE	ECO	APPR
THIRD ANGLE PROJ.	NC	INITIAL RELEASE	19-Oct-11	XXX	--
	A	ADD BeCu RETAINER RING	27-Apr-12	2297	--
	B	MODIFY OUTER CONTACT TO IMPROVE PERFORMANCE	09-Aug-12	2355	CL
	C	ADD GEPCO CABLE CALLOUT	21-Sep-12	2377	RV
	D	ADD CONTACT PIN CRIMP OPTION	25-Apr-13	2468	MB
	E	FREQUENCY DC-6 GHz WAS DC-3 GHz	1/22/16	50654	CL

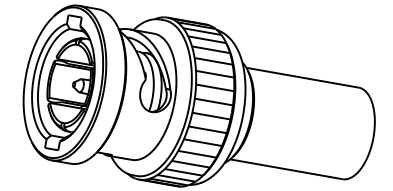
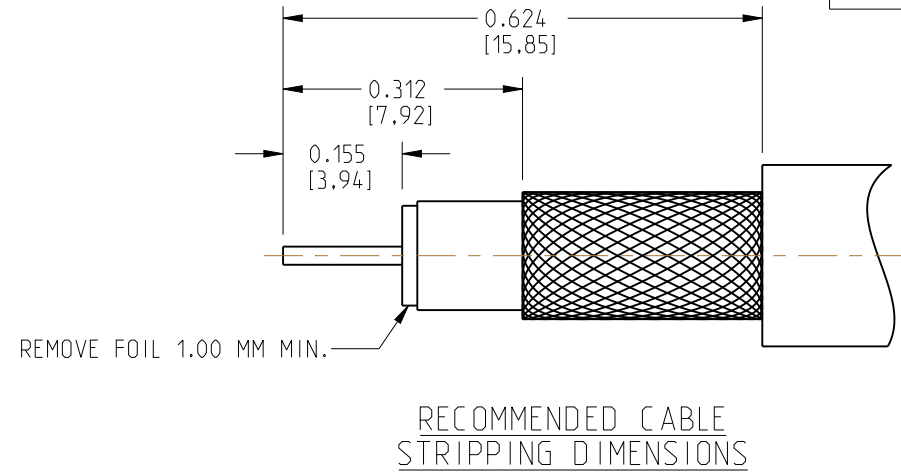

SCALE 1.500

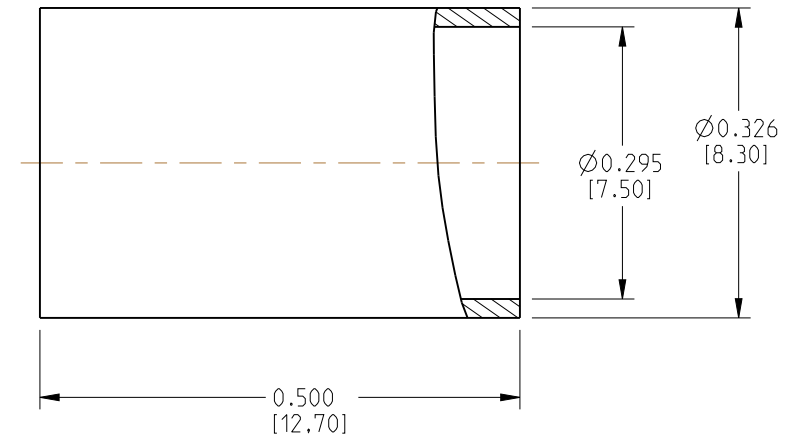
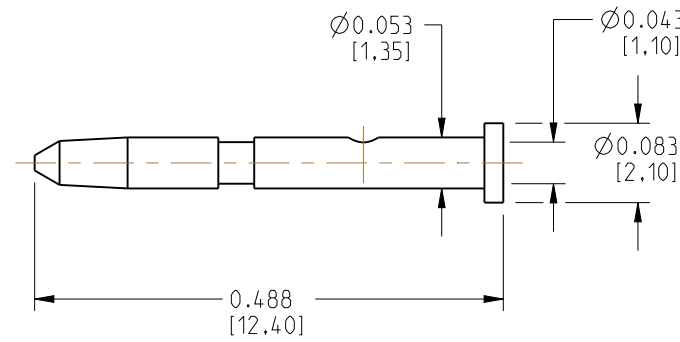
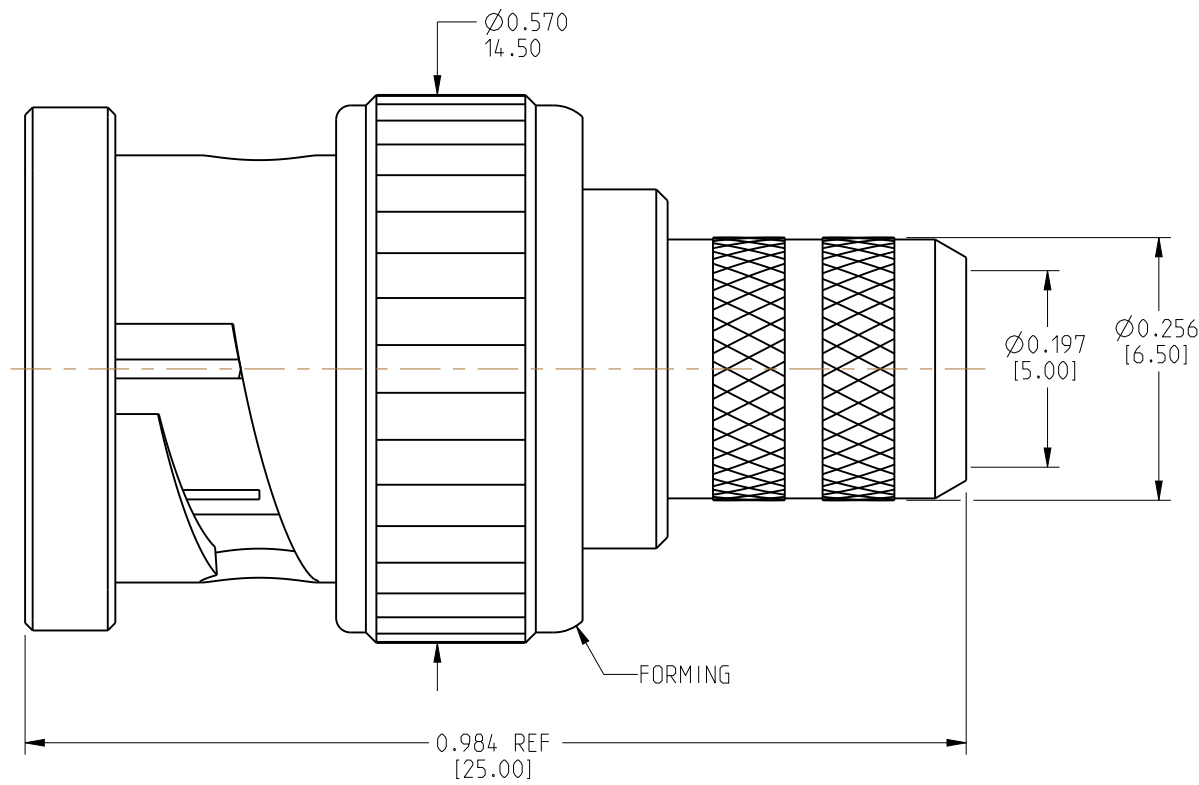

10	FERRULE	BRASS	NICKEL	1
9	CONTACT PIN	BRASS	GOLD	1
8	RING	BRASS	NICKEL	1
7	WASHER	BRASS	NICKEL	1
6	SPRING	SK5	NICKEL	1
5	GASKET	RUBBER	RED	1
4	OUTER CONTACT	BERYLLIUM COPPER	NICKEL	1
3	INSULATOR	PTFE	NATURAL	1
2	BODY	BRASS	NICKEL	1
1	SHELL	BRASS	NICKEL	1
S.NO	DESCRIPTION	MATERIAL	FINISH	QTY.

UNLESS OTHERWISE SPECIFIED, DIMENSIONS ARE IN INCHES AND TOLERANCES ARE:
 2 PLACE DECIMAL ±.015 (0,381 mm) 3 PLACE DECIMAL ±.005 (0,127 mm) ANGLES ± 1°

NOTICE - These drawings, specifications, or other data (1) are, and remain the property of Amphenol Corp. (2) must be returned upon request; and (3) are confidential and not to be disclosed to any person other than those to whom they are given by Amphenol Corp. The furnishing of these drawings, specifications, or other data by Amphenol Corp., or to any other person to anyone for any purpose is not to be regarded by implication or otherwise in any manner licensing, granting rights or permitting such holder or any other person to manufacture, use or sell any product, process or design, patented or otherwise, that may in any way be related to or disclosed by said drawings, specifications, or other data.

MATERIAL	SEE BOM TABLE
REFERENCE	

DRAWN	CLEMENT	DATE	25-Apr-13
ENGINEER	CLEMENT	DATE	25-Apr-13
APPROVED		DATE	
CAD FILE			

TITLE
 BNC CRIMP PLUG - 75 OHM
 FOR BELDEN 1694A AND
 GEPCO VSD2001 CABLE

Amphenol Connex	
SCALE: 4.0:1	SHEET 1 OF 1
DWG SIZE B	DRAWING NO. 112957-11
	REV E