

| | | | | | | | |
|-----|------|-----------|-----|-------------|---------|-----|------|
| LOC | DIST | REVISIONS | | | | | |
| DW | | P | LTR | DESCRIPTION | DATE | DWN | APVD |
| | | A | | RELEASED | 18MAR10 | SC | WK |

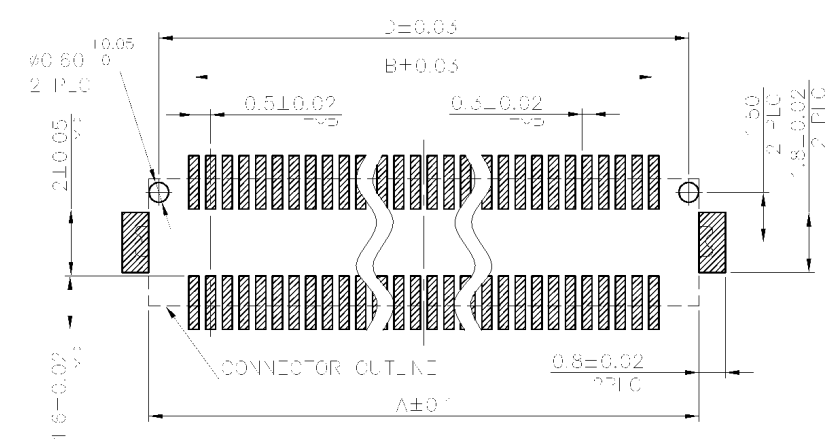

RECOMMENDED P.C. BOARD LAYOUT
 (COMPONENT SIDE) TOLERANCE: ±0.05

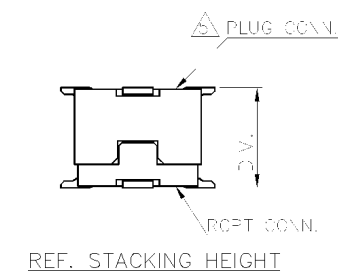
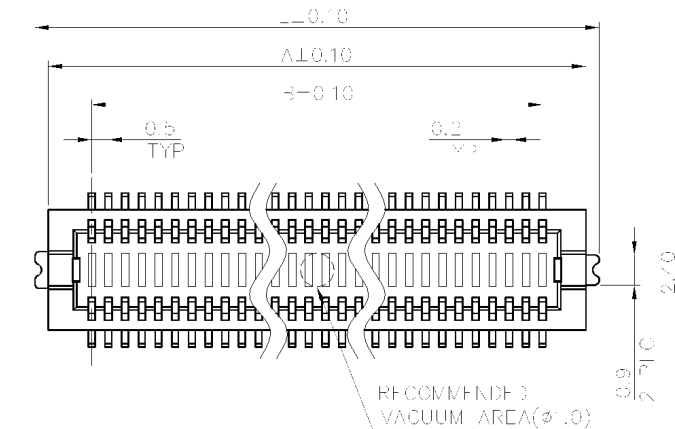
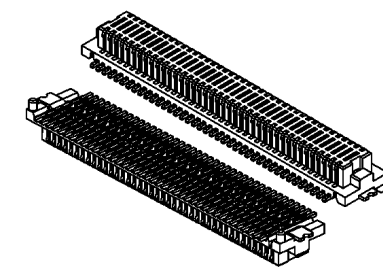
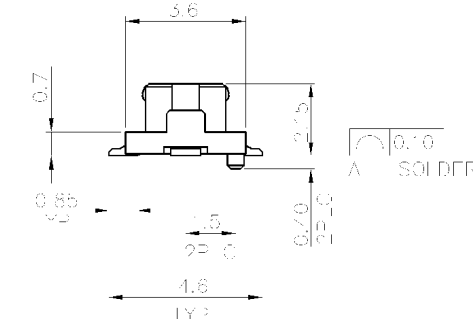
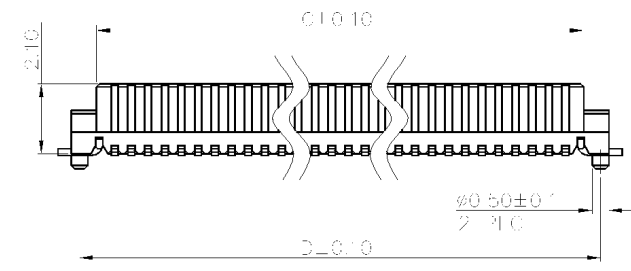

- NOTE:
- MATERIAL:
 HOUSING: THERMOPLASTIC (LCP) WITH 30% GF, UL 94V-0, BLACK COLOR.
 CONTACTS: PHOSPHOR BRONZE.
 PEGS: BRASS.
 - FINISH:
 CONTACTS: 0.254µm [10µ"] MIN. GOLD PLATED ON CONTACT AREA, GOLD FLASH ON SOLDER TAIL, WITH 1.27µm [50µ"] MIN. NICKEL UNDERPLATING.
 PEGS: 2.54µm [100µ"] MIN. MATTE-TIN OVER 1.27µm [50µ"] MIN NICKEL.
 - REFLOW SOLDER CAPABLE TO 260°C AS PER TE SPEC. TEC-109-201, CONDITION B.
 - NO TE LOGO AND DATE CODE ON THE PRODUCT.
 - PLUG PART NUMBERS (BASE NO.#):
 5.1. DIM.H=3MM: 1775167 THRU 1775185, AND 2041250.
 5.2. DIM.H=5MM: 1775186
 - LOW HALOGEN SPECIFICATION:
 CHLORINE(Cl): 900ppm MAX.
 BROMINE(Br): 900ppm MAX.

| | | | | | | | |
|--------|------------|-------|-------|-------|-------|-----------------|-------------|
| 0.33g | 22.90 | 21.60 | 20.60 | 19.50 | 22.10 | 80 | 8-2041251-0 |
| 0.10g | 7.90 | 6.60 | 5.60 | 4.50 | 7.10 | 20 | 2-2041251-0 |
| WEIGHT | DIMENSIONS | | | | | NO. OF CONTACTS | PART NUMBER |

| | | | | | | | |
|---|--|------------------|-----------|------------------|--|---|-----------|
| THIS DRAWING IS A CONTROLLED DOCUMENT. | | DWN | S. CHIEN | 18MAR2010 | Tyco Electronics Corporation Taipei, Taiwan | | |
| DIMENSIONS: MM | | CHK | S. CHIEN | 18MAR2010 | NAME | | |
| TOLERANCES UNLESS OTHERWISE SPECIFIED: | | APVD | W. KODAMA | 18MAR2010 | PRODUCT SPEC | | |
| 0 PLC ± - 1 PLC ± 0.3 2 PLC ± 0.2 3 PLC ± 0.15 4 PLC ± - ANGLES ± ± 3° | | APPLICATION SPEC | | 108-57578 | | BOARD TO BOARD CONNECTOR, 0.5mm PITCH, FINE-MATE, RECEPTACLE, WITH BOSSES & PEG | |
| MATERIAL SEE NOTE | | FINISH SEE NOTE | | WEIGHT | SEE TABLE | SIZE | A3 |
| | | | | W. KODAMA | 108-57578 | CAGE CODE | 000779 |
| | | | | CUSTOMER DRAWING | | DRAWING NO | C=2041251 |
| | | | | | | RESTRICTED TO | - |
| | | | | | | SCALE | - |
| | | | | | | SHEET | 1 OF 2 |
| | | | | | | REV | A |

| | | | | | | | |
|-----|------|-----------|-----|--------------|------|-----|------|
| LOC | DIST | REVISIONS | | | | | |
| DW | | P | LTR | DESCRIPTION | DATE | DWN | APVD |
| | | | | SEE SHEET 1. | | | |

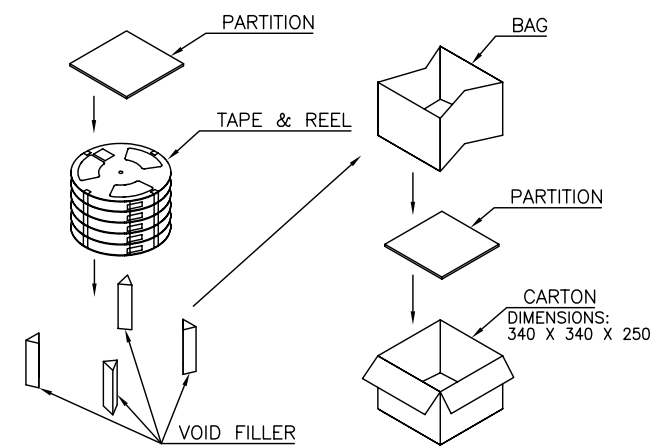
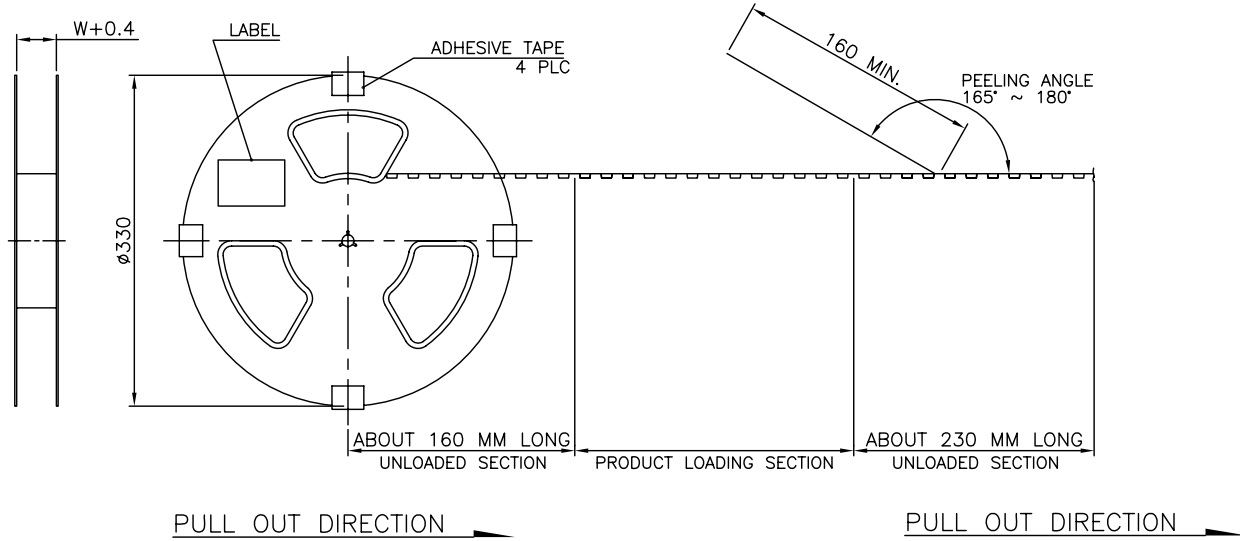

- NOTE:
- PACKAGING MATERIAL IN PLASTIC, RUBBER, INK, PIGMENT AND PAINT MUST MEET CONTROLLED SUBSTANCES BELOW.
 * CADMIUM AND CADMIUM COMPOUNDS NOT TO EXCEED: 5 PPM.
 * LEAD, CADMIUM, CHROM VI AND MERCURY NOT TO EXCEED :100 PPM (COMBINED).
 - EACH BAG SHALL BE INCLUDED:
 * DESICCANT
 - CARRIER TAPES, COVER TAPES, REELS AND TAPED COMPONENTS MUST MEET THE REQUIREMENTS DEFINED PER EIA-481-B.
 - CARRIER TAPES & COVER TAPES MATERIAL: P.S.
 - PEELING FORCE: 10g ~ 130g.

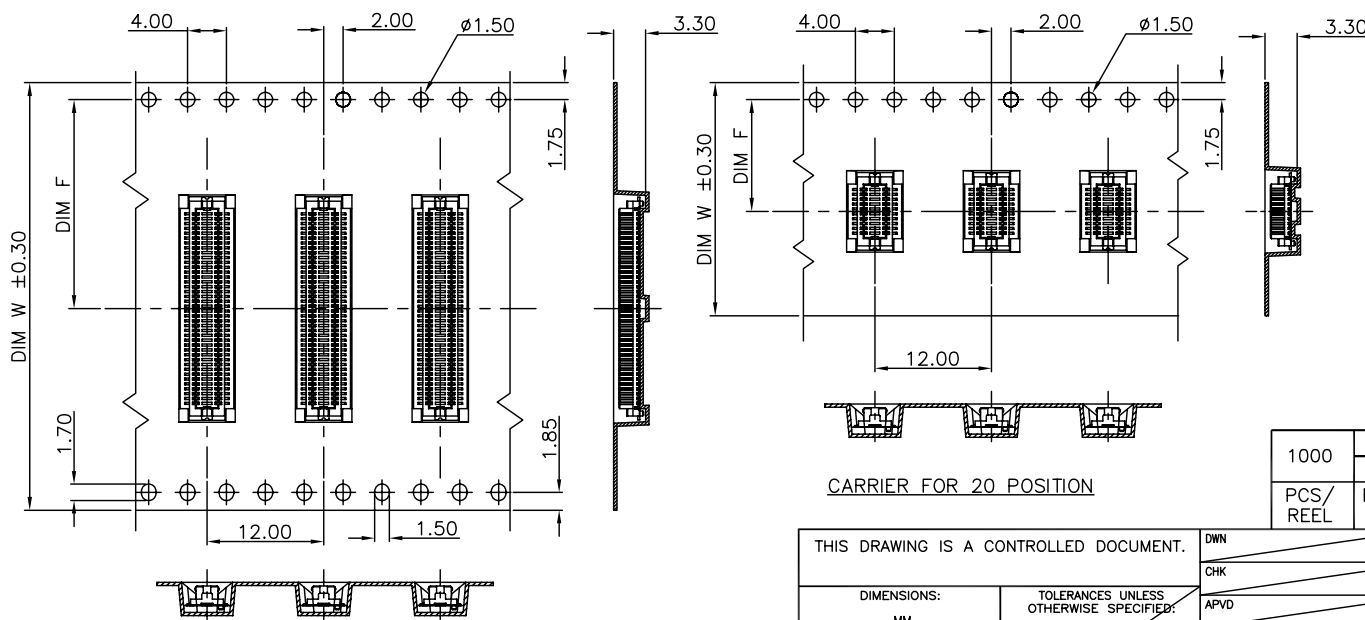

| | | | | | | | |
|-----------|------------|----------|-------|-------|----------|----------|-------------|
| 1000 | 4 | 4000 | 20.2 | 44 | 4.58 | 1.32 | 8-2041251-0 |
| | 10 | 10000 | 7.5 | 16 | 6.89 | 0.99 | 2-2041251-0 |
| PCS/ REEL | REELS/ BOX | QUANTITY | DIM F | DIM W | G/W (KG) | N/W (KG) | PART NUMBER |

THIS DRAWING IS A CONTROLLED DOCUMENT.

Tyco Electronics Tyco Electronics Corporation
Taipei, Taiwan

NAME: BOARD TO BOARD CONNECTOR, 0.5mm PITCH, FINE-MATE, RECEPTACLE, WITH BOSSES & PEG

SIZE: A3 CAGE CODE: 00779 DRAWING NO: G=2041251 RESTRICTED TO: []

WEIGHT: SEE TABLE

CUSTOMER DRAWING SCALE: [] SHEET: 2 OF 2 REV: A

| | |
|----------------|--|
| DIMENSIONS: MM | TOLERANCES UNLESS OTHERWISE SPECIFIED: |
| | 0 PLC ± - |
| | 1 PLC ± - |
| | 2 PLC ± - |
| | 3 PLC ± - |
| | 4 PLC ± - |
| | ANGLES ± - |
| MATERIAL | FINISH |