

PROPER USE GUIDELINES

Cumulative Trauma Disorders can result from the prolonged use of manually powered hand tools. Hand tools are intended for occasional use and low volume applications. A wide selection of powered application equipment for extended-use, production operations is available.

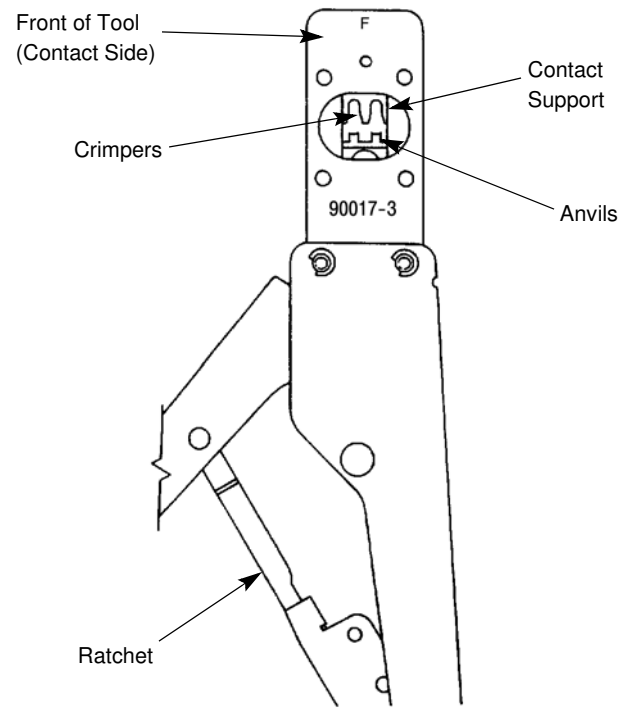

Figure 1

1. INTRODUCTION

Hand Crimping Tool 90017-3 is designed to crimp the AMP-LEAF* loose-piece (LP) contacts listed in Figure 2. Contacts with the anti-tangling feature **MUST** be crimped in this tool. Read these instructions thoroughly before crimping any contacts.

NOTE *Measurements are in millimeters [followed by inch equivalents in brackets]. Figures and illustrations are for identification only and are not drawn to scale.*

Reasons for reissue of this instruction sheet are provided in Section 6, REVISION SUMMARY.

2. DESCRIPTION

This tool features two fixed dies (crimpers), two movable dies (anvils), a contact locator, a contact support, a wire stop, two green color code dots, and a tool ratchet.

The contact locator positions the contact between the crimping dies. In use, it rests in the contact locator slot. See Figures 2 and 3.

The contact support prevents the contact from bending during the crimping procedure. The wire stop aids in locating the wire in the contact.

The green color code dots on the **BACK** of the tool indicate the wire range of the tool crimp sections. Notice that the applicable loose-piece contacts have a green color dot on the bottom side. See Figures 2 and 3.

The ratchet ensures full crimping of the contact. Once engaged, the ratchet will not release until the tool handles have been fully closed.

CAUTION *The crimping dies bottom before the ratchet releases. This is a design feature that ensures maximum electrical and tensile performance of the crimp. Do NOT re-adjust the ratchet.*

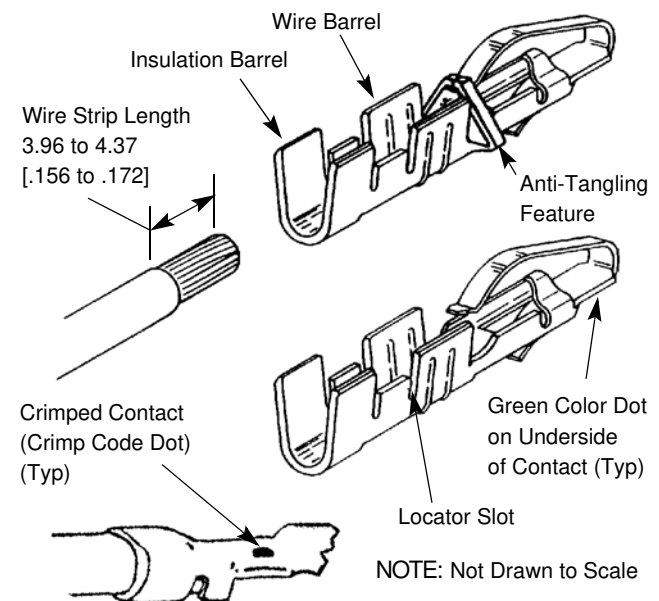

WIRE		CONTACT NO.		CRIMP SECTION (Wire Size Marking and Crimp Code)
SIZE (AWG)	INSUL DIA	LP	STRIP	
22 to 20	1.40 to 2.03 [.055 to .080]	42840 583989†	42717 --	22-20 1 Dot
(2) 22	3.05 [.120] Max Total	60082	60030	2-22 1-18 2 Dots
(1) 18	1.63 to 2.03 [.064 to .080]	583272 583994†	583271- -	

† Contacts with anti-tangling feature.

Figure 2

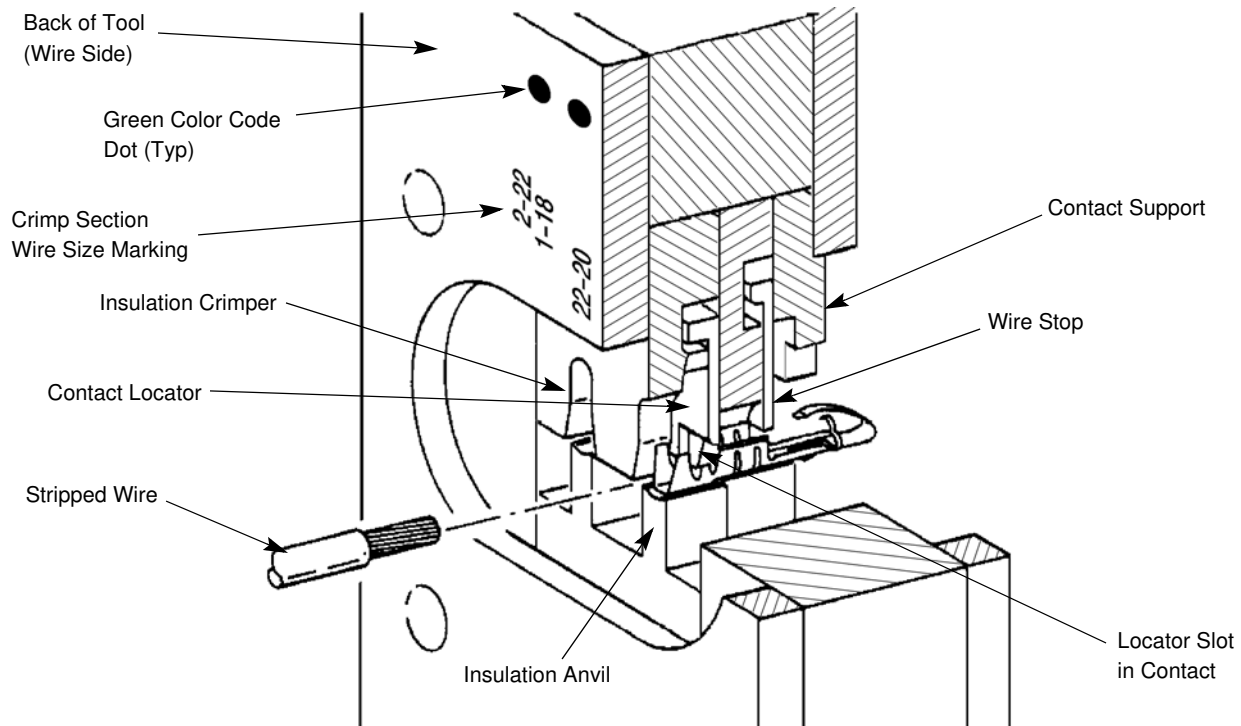

Figure 3

3. CRIMPING PROCEDURE

Refer to Figure 2 and select wire within the specified wire size and insulation diameter. If using two wires, note that the combined insulation diameter must not exceed 3.05 [.120]. Strip the wire(s) to the length indicated - do not cut or nick the wire strands.

Notice that each crimp section has the applicable wire size stamped above it. Use this marking and the wire size that you are using to determine the proper crimp section.

Select the applicable loose-piece contact with a green color dot and proceed as follows:

1. Hold the tool so that the back (wire side) is facing you.
2. Make sure that the ratchet is released. Squeeze the tool handles together and allow them to open fully.
3. Looking straight into the back of the tool, insert the contact (insulation barrel first) into the front of the appropriate crimp section. See Figure 3.
4. Position the contact in the crimpers so that the locator enters the locator slot in the contact.
5. Hold the contact in this position and squeeze the tool handles together until the insulation anvil starts entry into the insulation crimper. Do NOT deform the insulation barrel or wire barrel.
6. Insert a properly-stripped wire through the wire slot of the locator and into the wire barrel of the contact until the wire butts against the wire stop.

7. While holding the wire in place, squeeze the tool handles together until the ratchet releases.

8. Allow the tool handles to open fully and remove the crimped contact.

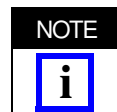

Check that the proper crimp code dot(s) appear on the bottom of the wire barrel. See Figure 2.

4. MAINTENANCE/INSPECTION

4.1. Daily Maintenance

Remove all foreign particles with a clean, soft brush or a clean, soft, lint-free cloth. Make sure the proper retaining pins are in place and are secured with the proper retaining rings. If foreign matter cannot be removed easily, or if the proper replacement parts are not available, return the tool to your supervisor.

Make sure all pivot points and bearing surfaces are protected with a thin coat of any good SAE 20 motor oil. Do NOT oil excessively. When the tool is not in use, keep the handles closed to prevent objects from becoming lodged between the dies, and store the tool in a clean, dry area.

4.2. Periodic Inspection

Regular inspection should be performed by quality control personnel. A record of scheduled inspections should remain with the tool and/or be supplied to the supervisory personnel responsible for the tool. Though recommendations call for at least one inspection a

month, the inspection frequency should be based on the amount of use, ambient working conditions, operator training and skill, and established company standards. These inspections should be performed in the following sequence:

A. Visual Inspection

1. Remove all lubrication and accumulated film by immersing the tool (handles partially closed) into a suitable degreaser that will not affect paint or plastic material.
2. Make certain all retaining pins are in place and are secured with the proper retaining rings. If replacements are necessary, refer to Figure 5.
3. Close the tool handles until the ratchet releases, and then allow the handles to open freely. If they do not open quickly and fully, then the spring is defective and must be replaced (see Section 5, REPLACEMENT AND REPAIR).
4. Inspect the tool, with special emphasis on checking for worn, cracked, or broken crimping dies. If damage to any part of the head is evident, return the tool for evaluation and repair (see Section 5, REPLACEMENT AND REPAIR).

B. Crimp Height Inspection

Crimp height inspection is performed through the use of a micrometer with a modified anvil, commonly referred to as a crimp height comparator. TE does not market crimp height comparators. Refer to Instruction Sheet 408-7424 for detailed information on obtaining and using a crimp height comparator.

Proceed as follows:

1. Refer to the chart in Figure 4 and select a contact and a wire (maximum size) for each crimp section.
2. Refer to Section 3, CRIMPING PROCEDURE, and crimp the contact(s) accordingly.
3. Using a crimp height comparator, measure the wire barrel crimp height as shown in Figure 4. If the crimp height conforms to that shown in the chart, the tool is considered dimensionally correct. If not, return the tool for evaluation and repair (refer to Section 5, REPLACEMENT AND REPAIR).

C. Ratchet Inspection

Obtain a 0.025-mm [.001-in.] shim that is suitable for checking the clearance between the bottoming surfaces of the crimping dies. Proceed as follows:

1. Select a contact and maximum size wire for the hand tool.
2. Position the contact and wire between the crimping dies, as described in Section 3, CRIMPING PROCEDURE.

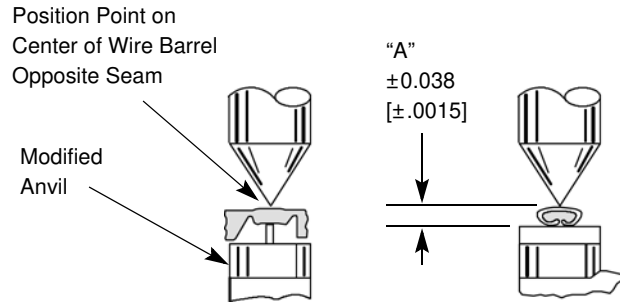

CONTACT NUMBER (LP)	WIRE SIZE AWG (Max)	CRIMP SECT (Wire Size Marking)	CRIMP HEIGHT DIM. "A"
42840 583989	20	22-20	0.978 [.0385]
60082	(2) 22	2-22 1-18	1.130 [.0445]
583272 583994	18		

Figure 4

3. Holding the wire in place, squeeze the tool handles together until the CERTI-CRIMP ratchet releases. Hold the handles in this position, maintaining just enough tension to keep the dies closed.

4. Check the clearance between the bottoming surfaces of the crimping dies. If the clearance is 0.025 [.001] or less, the ratchet is satisfactory. If the clearance exceeds 0.025 [.001], the ratchet is out of adjustment and must be repaired.

If the tool conforms to these inspection procedures, lubricate it with a thin coat of any good SAE 20 motor oil and return it to service.

5. REPLACEMENT AND REPAIR

The parts listed in Figure 5 are customer-replaceable. A complete inventory can be stocked and controlled to prevent lost time when replacement of parts is necessary. Order replacement parts through your TE Connectivity, or call 1-800-526-5142, or send a facsimile of your purchase order to 1-717-986-7605, or write to:

CUSTOMER SERVICE (038-035)
 TYCO ELECTRONICS CORPORATION
 PO BOX 3608
 HARRISBURG PA 17105-3608

For customer repair service, call 1-800-526-5136.

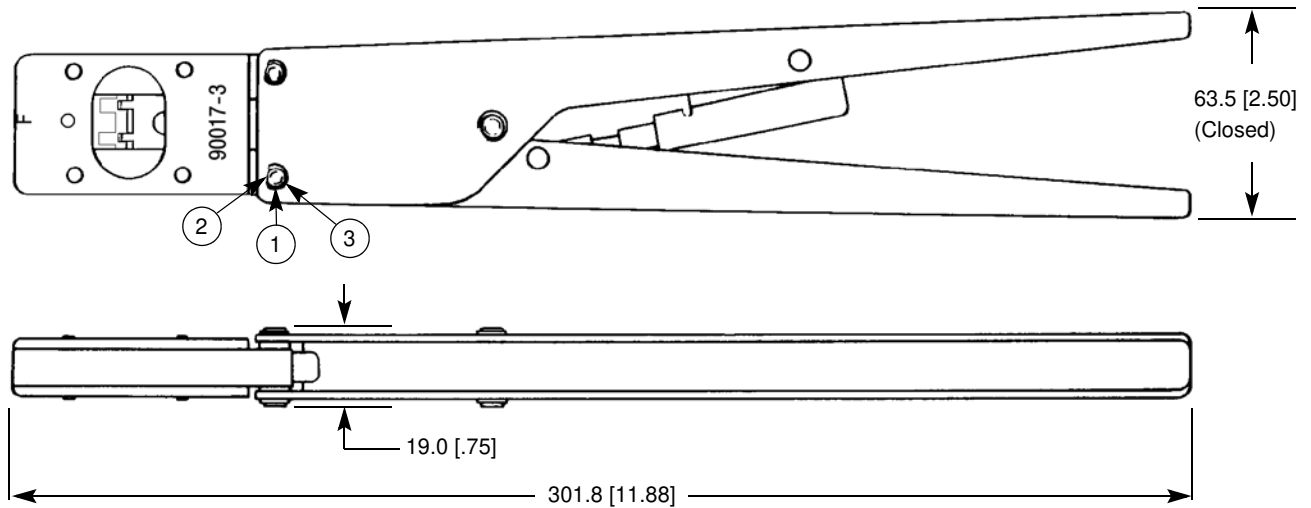

WEIGHT: 567 g [1 lb 4 oz]

REPLACEMENT PARTS			
ITEM	PART NUMBER	DESCRIPTION	QTY PER TOOL
1	21045-3	Ring, Retaining	4
2	125077-3	Pin, Retaining (.187 D x .661 L)	2
3	125115-1	Spacer	4

Figure 5

6. REVISION SUMMARY

Since the previous version of this document, the following changes were made:

- Updated trademark references for tool and ratchet (throughout).
- Revised crimp height comparator sourcing information in Paragraph 4.2.B.
- Updated document to corporate requirements.