

Absolute maximum ratings

($T_a=25^\circ\text{C}$)

Symbol	Ratings	Unit
V_{CB0}	120	V
V_{CEO}	100	V
V_{EBO}	6	V
I_c	4	A
I_{cP}	6 (PW \leq 1ms, Du \leq 50%)	A
I_B	0.5	A
P_T	5 ($T_a=25^\circ\text{C}$)	W
	25 ($T_c=25^\circ\text{C}$)	
V_{ISO}	1000 (Between fin and lead pin, AC)	V _{rms}
T_j	150	$^\circ\text{C}$
T_{stg}	-40 to +150	$^\circ\text{C}$
θ_{j-c}	5	$^\circ\text{C}/\text{W}$

Electrical characteristics

($T_a=25^\circ\text{C}$)

Symbol	Specification			Unit	Conditions
	min	typ	max		
I_{CBO}			10	μA	$V_{CB}=120\text{V}$
I_{EBO}			10	mA	$V_{EB}=6\text{V}$
V_{CEO}	100			V	$I_c=10\text{mA}$
hFE	2000				$V_{CE}=4\text{V}$, $I_c=2\text{A}$
$V_{CE(sat)}$			1.5	V	$I_c=2\text{A}$, $I_B=10\text{mA}$

Equivalent circuit diagram

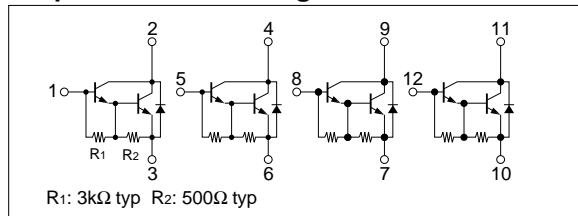

Ic-VCE Characteristics (Typical)

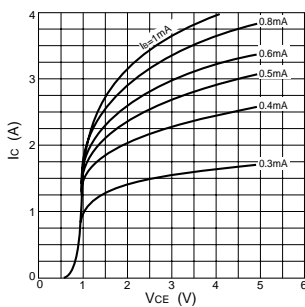

hFE-Ic Characteristics (Typical)

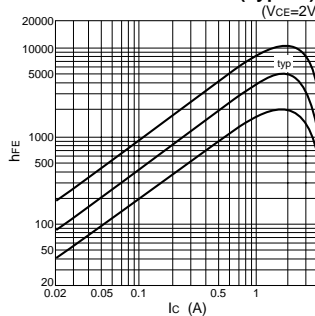

hFE-Ic Temperature Characteristics (Typical)

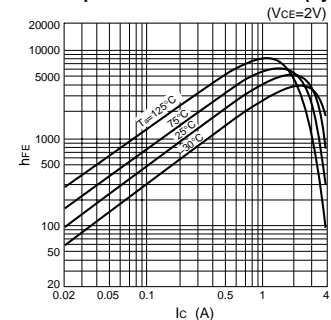

VCE(sat)-Ic Temperature Characteristics (Typical)

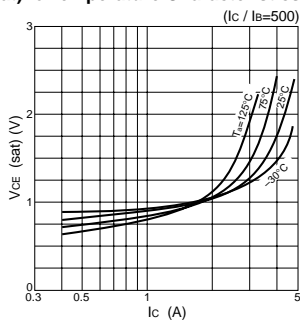

VCE(sat)-Ib Characteristics (Typical)

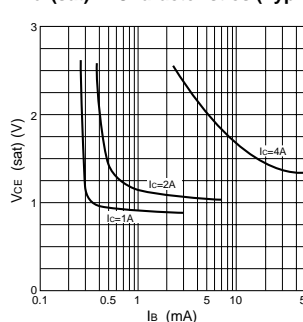

Ic-VBE Temperature Characteristics (Typical)

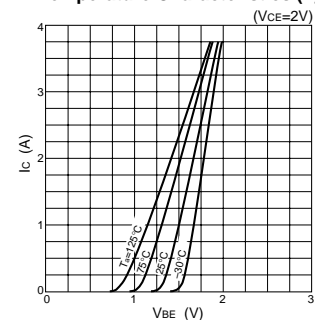

θ_{j-a} -PW Characteristics

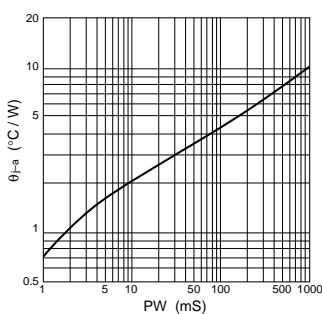

Pr-Ta Characteristics

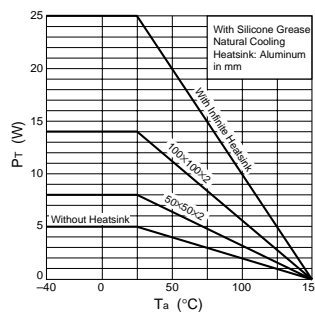

Safe Operating Area (SOA)

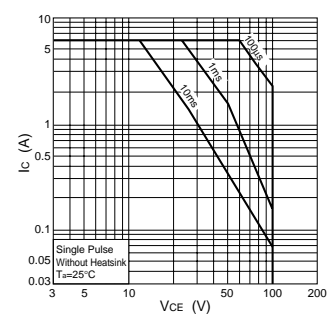

• SIP 8 (STA8Pin)

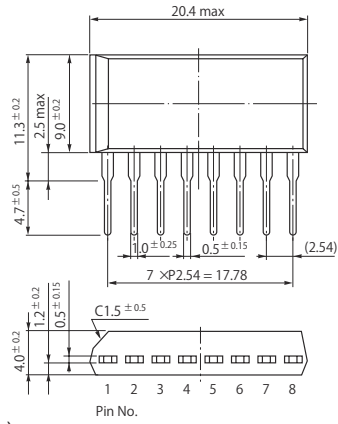

• SIP 10 (STA10Pin)

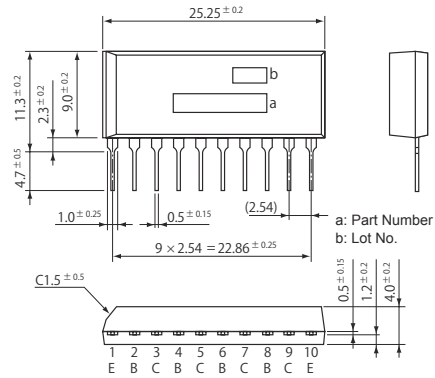

• SIP 12 (SMA12Pin)

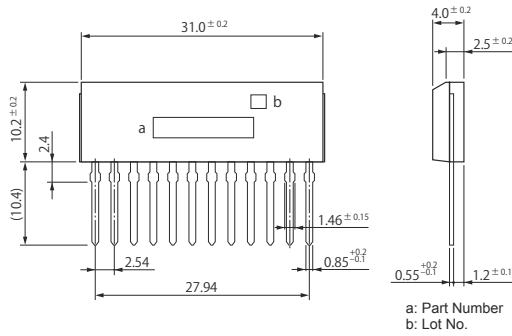

• SIP 15 (SMA15Pin)

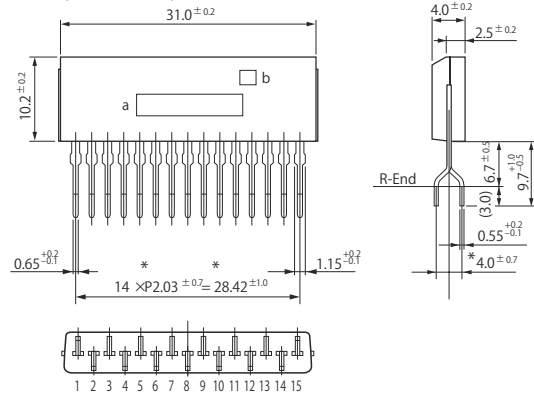

• SIP 12 with Fin (SLA12Pin)

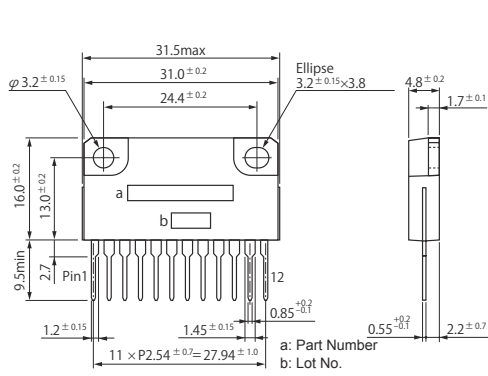

• SIP 15 with Fin (SLA15Pin)

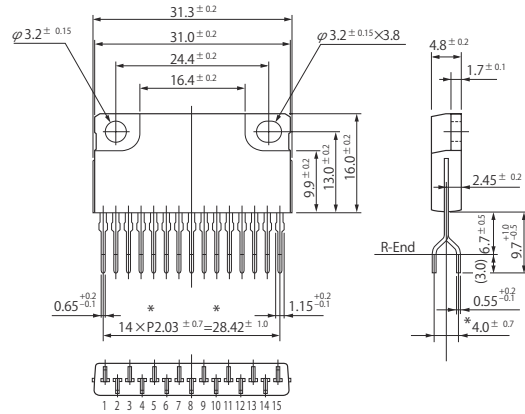

• SIP 21 with Fin (SLA21Pin)

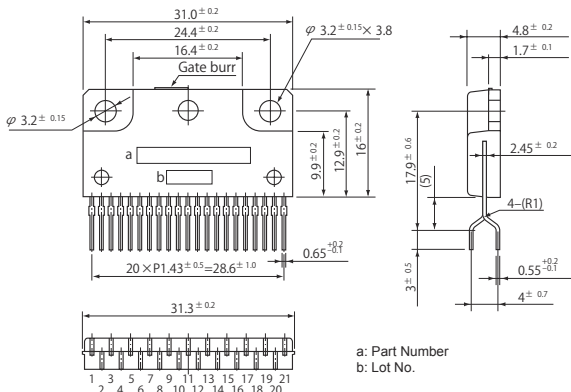

(Unit:mm)