

## General Description

The ICS874003-05 is a high performance Differential-to-LVDS Jitter Attenuator designed for use in PCI Express systems. In some PCI Express systems, such as those found in desktop PCs, the PCI Express clocks are generated from a low bandwidth, high phase noise PLL frequency synthesizer. In these systems, a jitter attenuator may be required to attenuate high frequency random and deterministic jitter components from the PLL synthesizer and from the system board. The ICS874003-05 has a bandwidth of 6.2MHz with <1dB peaking, easily meeting PCI Express Gen2 PLL requirements.

The ICS874003-05 uses IDT's 3<sup>rd</sup> Generation FemtoClock™ PLL technology to achieve the lowest possible phase noise. The device is packaged in a 20-Lead TSSOP package, making it ideal for use in space constrained applications such as PCI Express add-in cards.

## Features

- Three differential LVDS output pairs
- One differential clock input
- CLK/nCLK can accept the following differential input levels: LVPECL, LVDS, LVHSTL, HCSL, SSTL
- Input frequency range: 98MHz to 128MHz
- Output frequency range: 98MHz to 320MHz
- VCO range: 490MHz - 640MHz
- Supports PCI-Express Spread-Spectrum Clocking
- High PLL bandwidth allows for better input tracking
- PCI Express (2.5 Gb/s) and Gen 2 (5 Gb/S) jitter compliant
- 0°C to 70°C ambient operating temperature
- Full 3.3V operating supply
- Available in lead-free (RoHS 6) packages

F\_SEL[2:0] Function Table

Inputs			Outputs	
F_SEL2	F_SEL1	F_SEL0	QA[0:1], nQA[0:1]	QB0, nQB0
0 (default)	0 (default)	0 (default)	÷2	÷2
1	0	0	÷5	÷2
0	1	0	÷4	÷2
1	1	0	÷2	÷4
0	0	1	÷2	÷5
1	0	1	÷5	÷4
0	1	1	÷4	÷5
1	1	1	÷4	÷4

## Pin Assignment

QA1	1	20	nQA1
VDDO	2	19	VDDO
QA0	3	18	QB0
nQA0	4	17	nQB0
MR	5	16	F_SEL2
F_SEL0	6	15	OEB
nc	7	14	GND
VDDA	8	13	nCLK
F_SEL1	9	12	CLK
VDD	10	11	OEA

**ICS874003-05**  
**20-Lead TSSOP**  
**6.5mm x 4.4mm x 0.925mm package body**  
**G Package**  
**Top View**

## Block Diagram

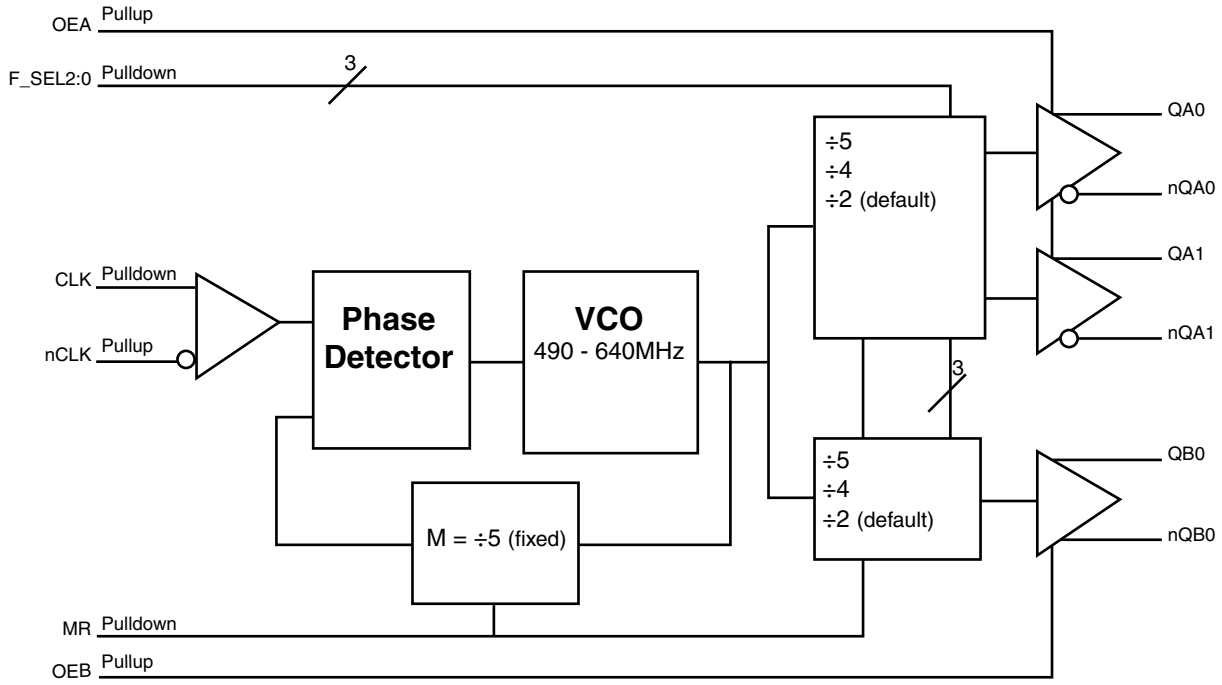

## Pin Descriptions and Characteristics

**Table 1. Pin Descriptions**

Number	Name	Type		Description
1, 20	QA1, nQA1	Output		Bank A differential output pair. LVDS interface levels.
2, 19	V <sub>DDO</sub>	Power		Output supply pins.
3, 4	QA0, nQA0	Output		Bank A differential output pair. LVDS interface levels.
5	MR	Input	Pulldown	Active HIGH Master Reset. When logic HIGH, the internal dividers are reset causing the true outputs (nQx) to go low and the inverted outputs (Qx) to go high. When logic LOW, the internal dividers and the outputs are enabled. LVCMOS/LVTTL interface levels.
6, 9, 16	F_SEL0, F_SEL1, F_SEL2	Input	Pulldown	Frequency select pin for QAx/nQAx and QB0/nQB0 outputs. LVCMOS/LVTTL interface levels.
7	nc	Unused		No connect.
8	V <sub>DDA</sub>	Power		Analog supply pin.
10	V <sub>DD</sub>	Power		Core supply pin.
11	OEA	Input	Pullup	Output enable pin for QA pins. When HIGH, the QAx/nQAx outputs are active. When LOW, the QAx/nQAx outputs are in a high-impedance state. LVCMOS/LVTTL interface levels.
12	CLK	Input	Pulldown	Non-inverting differential clock input.
13	nCLK	Input	Pullup	Inverting differential clock input.
14	GND	Power		Power supply ground.
15	OEB	Input	Pullup	Output enable pin for QB0 pins. When HIGH, the QB0/nQB0 outputs are active. When LOW, the QB0/nQB0 outputs are in a high-impedance state. LVCMOS/LVTTL interface levels.
17, 18	nQB0, QB0	Output		Bank B differential output pair. LVDS interface levels.

NOTE: *Pullup* and *Pulldown* refer to internal input resistors. See Table 2, *Pin Characteristics*, for typical values.

**Table 2. Pin Characteristics**

Symbol	Parameter	Test Conditions	Minimum	Typical	Maximum	Units
C <sub>IN</sub>	Input Capacitance			4		pF
R <sub>PULLUP</sub>	Input Pullup Resistor			51		kΩ
R <sub>PULLDOWN</sub>	Input Pulldown Resistor			51		kΩ

**Table 3. Output Enable Function Table**

Inputs		Outputs	
OEA	OEB	QA[0:1], nQA[0:1]	QB0, nQB0
0	0	High Impedance	High Impedance
1 (default)	1 (default)	Enabled	Enabled

## Absolute Maximum Ratings

NOTE: Stresses beyond those listed under *Absolute Maximum Ratings* may cause permanent damage to the device. These ratings are stress specifications only. Functional operation of the product at these conditions or any conditions beyond those listed in the *DC Characteristics* or *AC Characteristics* is not implied. Exposure to absolute maximum rating conditions for extended periods may affect product reliability.

Item	Rating
Supply Voltage, $V_{DD}$	4.6V
Inputs, $V_I$	-0.5V to $V_{DD} + 0.5V$
Outputs, $I_O$ (LVDS) Continuous Current Surge Current	10mA 15mA
Package Thermal Impedance, $\theta_{JA}$	86.7°C/W (0 mps)
Storage Temperature, $T_{STG}$	-65°C to 150°C

## DC Electrical Characteristics

**Table 4A. LVDS Power Supply DC Characteristics,  $V_{DD} = V_{DDO} = 3.3V \pm 5\%$ ,  $T_A = 0^\circ C$  to  $70^\circ C$**

Symbol	Parameter	Test Conditions	Minimum	Typical	Maximum	Units
$V_{DD}$	Positive Supply Voltage		3.135	3.3	3.465	V
$V_{DDA}$	Analog Supply Voltage		$V_{DD} - 0.16$	3.3	$V_{DD}$	V
$V_{DDO}$	Output Supply Voltage		3.135	3.3	3.465	V
$I_{DD}$	Power Supply Current				75	mA
$I_{DDA}$	Analog Supply Current				16	mA
$I_{DDO}$	Output Supply Current				75	mA

**Table 4B. LVCMOS/LVTTL DC Characteristics,  $V_{DD} = V_{DDO} = 3.3V \pm 5\%$ ,  $T_A = 0^\circ C$  to  $70^\circ C$**

Symbol	Parameter	Test Conditions	Minimum	Typical	Maximum	Units
$V_{IH}$	Input High Voltage		2		$V_{DD} + 0.3$	V
$V_{IL}$	Input Low Voltage		-0.3		0.8	V
$I_{IH}$	Input High Current	OEA, OEB	$V_{DD} = V_{IN} = 3.465V$		5	$\mu A$
		F_SEL0, F_SEL1, F_SEL2, MR	$V_{DD} = V_{IN} = 3.465V$		150	$\mu A$
$I_{IL}$	Input Low Current	OEA, OEB	$V_{DD} = 3.465V, V_{IN} = 0V$	-150		$\mu A$
		F_SEL0, F_SEL1, F_SEL2, MR	$V_{DD} = 3.465V, V_{IN} = 0V$	-5		$\mu A$

**Table 4C. Differential DC Characteristics,  $V_{DD} = V_{DDO} = 3.3V \pm 5\%$ ,  $T_A = 0^\circ\text{C}$  to  $70^\circ\text{C}$** 

Symbol	Parameter	Test Conditions	Minimum	Typical	Maximum	Units
$I_{IH}$	Input High Current	CLK	$V_{DD} = V_{IN} = 3.465V$		150	$\mu\text{A}$
		nCLK	$V_{DD} = V_{IN} = 3.465V$		5	$\mu\text{A}$
$I_{IL}$	Input Low Current	CLK	$V_{DD} = 3.465V, V_{IN} = 0V$	-5		$\mu\text{A}$
		nCLK	$V_{DD} = 3.465V, V_{IN} = 0V$	-150		$\mu\text{A}$
$V_{PP}$	Peak-to-Peak Voltage; NOTE 1		0.15		1.3	V
$V_{CMR}$	Common Mode Input Voltage; NOTE 1, 2		GND + 0.5		$V_{DD} - 0.85$	V

NOTE 1:  $V_{IL}$  should not be less than -0.3V.

NOTE 2: Common mode input voltage is defined as  $V_{IH}$ .

**Table 4D. LVDS DC Characteristics,  $V_{DD} = V_{DDO} = 3.3V \pm 5\%$ ,  $T_A = 0^\circ\text{C}$  to  $70^\circ\text{C}$** 

Symbol	Parameter	Test Conditions	Minimum	Typical	Maximum	Units
$V_{OD}$	Differential Output Voltage		275	375	485	mV
$\Delta V_{OD}$	$V_{OD}$ Magnitude Change				50	mV
$V_{OS}$	Offset Voltage		1.20	1.35	1.50	V
$\Delta V_{OS}$	$V_{OS}$ Magnitude Change				50	mV

**Table 5. AC Characteristics,  $V_{DD} = V_{DDO} = 3.3V \pm 5\%$ ,  $T_A = 0^\circ C$  to  $70^\circ C$** 

Symbol	Parameter	Test Conditions	Minimum	Typical	Maximum	Units
$f_{MAX}$	Output Frequency		98		320	MHz
$t_{jit(cc)}$	Cycle-to-Cycle Jitter; NOTE 4				35	ps
$t_{sk(o)}$	Output Skew; NOTE 4, 5				145	ps
$t_{sk(b)}$	Bank Skew; NOTE 4, 6	Bank A			55	ps
$t_R / t_F$	Output Rise/Fall Time	20% to 80%	200		600	ps
odc	Output Duty Cycle		47		53	%
$t_j$	Phase Jitter Peak-to-Peak; NOTE 1, 3	100MHz output, Evaluation Band: 0Hz - Nyquist (clock frequency/2)		13.54		ps
		125MHz output, Evaluation Band: 0Hz - Nyquist (clock frequency/2)		13.13		ps
		250MHz output, Evaluation Band: 0Hz - Nyquist (clock frequency/2)		12.87		ps
$t_{REFCLK\_HF\_RMS}$	Phase Jitter RMS; NOTE 2, 3	100MHz output, High Band: 1.5MHz - Nyquist (clock frequency/2)		1.22		ps
		125MHz output, High Band: 1.5MHz - Nyquist (clock frequency/2)		1.17		ps
		250MHz output, High Band: 1.5MHz - Nyquist (clock frequency/2)		1.11		ps
$t_{REFCLK\_LF\_RMS}$	Phase Jitter RMS; NOTE 2, 3	100MHz output, Low Band: 10kHz - 1.5MHz		0.25		ps
		125MHz output, Low Band: 10kHz - 1.5MHz		0.22		ps
		250MHz output, Low Band: 10kHz - 1.5MHz		0.22		ps

NOTE: Electrical parameters are guaranteed over the specified ambient operating temperature range, which is established when the device is mounted in a test socket with maintained transverse airflow greater than 500 lpm. The device will meet specifications after thermal equilibrium has been reached under these conditions.

NOTE 1: Peak-to-peak jitter after applying system transfer function for the Common Clock Architecture. Maximum limit for PCI Express Gen 1 is 86ps peak-to-peak for a sample size of  $10^5$  clock periods. See IDT Application Note *PCI Express Reference Clock Requirements*, and also the *PCI Express Application section* of this datasheet which show each individual transfer function and the overall composite transfer function.

NOTE 2: RMS jitter after applying the two evaluation bands to the two transfer functions defined in the Common Clock Architecture and reporting the worst case results for each evaluation band. Maximum limit for PCI Express Generation 2 is 3.1ps rms for  $t_{REFCLK\_HF\_RMS}$  (High Band) and 3.0 ps RMS for  $t_{REFCLK\_LF\_RMS}$  (Low Band). See IDT Application Note *PCI Express Reference Clock Requirements* and also the *PCI Express Application section* of this datasheet which show each individual transfer function and the overall composite transfer function.

NOTE 3: Guaranteed only when input clock source is PCI Express Gen 2 compliant.

NOTE 4: This parameter is defined in accordance with JEDEC Standard 65.

NOTE 5: Defined as skew between outputs at the same supply voltage and with equal load conditions. Measured at the differential cross points.

NOTE 6: Defined as skew within a bank of outputs at the same supply voltage and with equal load conditions.

## Parameter Measurement Information

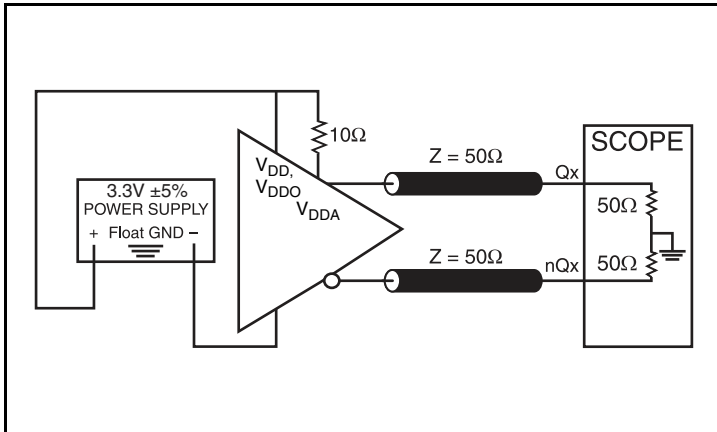

3.3V LVDS Output Load AC Test Circuit

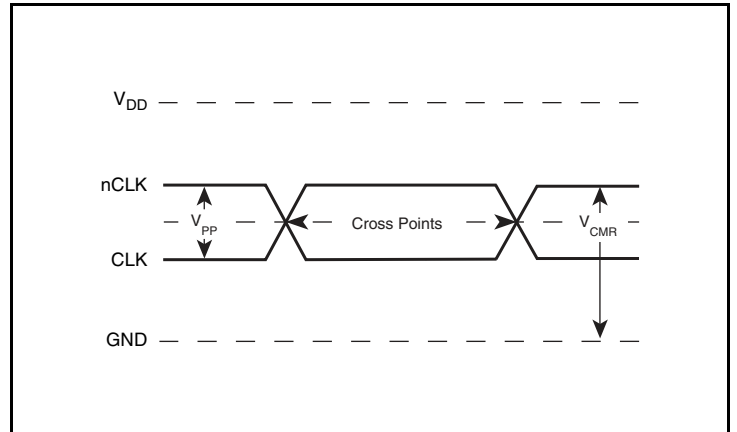

Differential Input Level

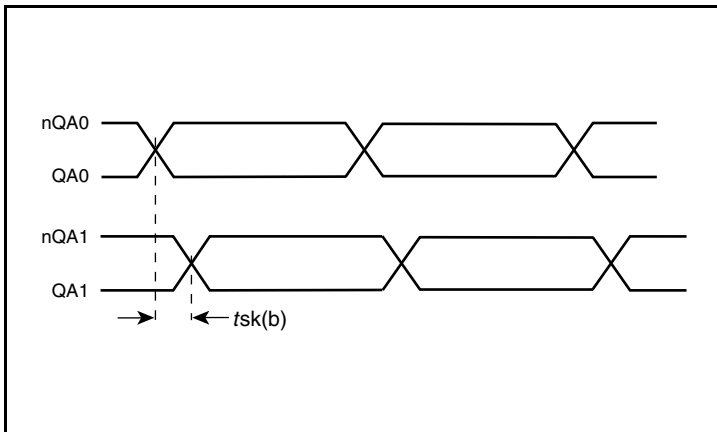

Bank Skew

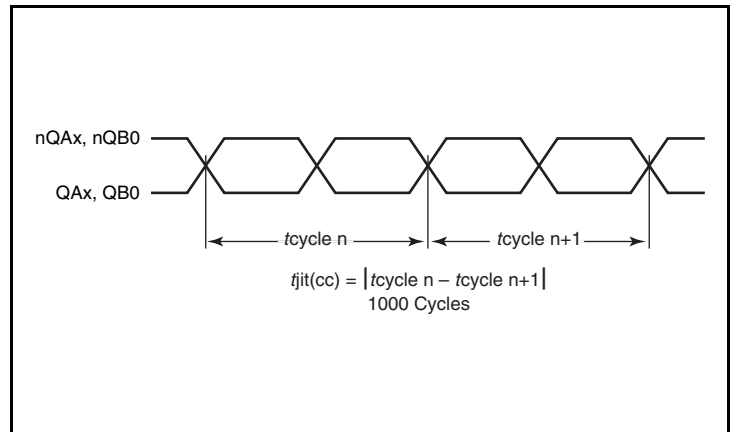

Cycle-to-Cycle Jitter

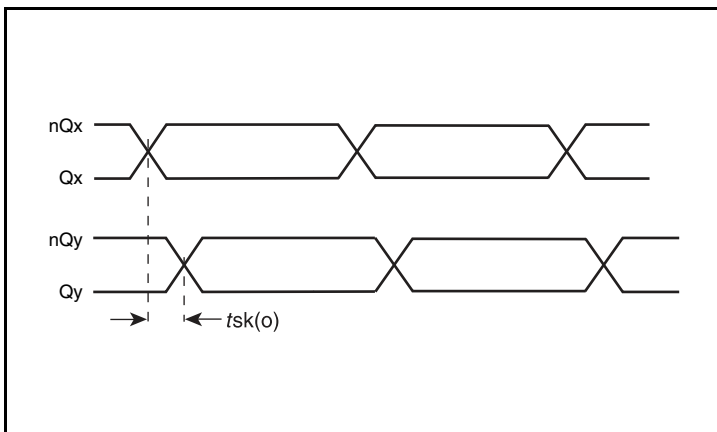

Output Skew

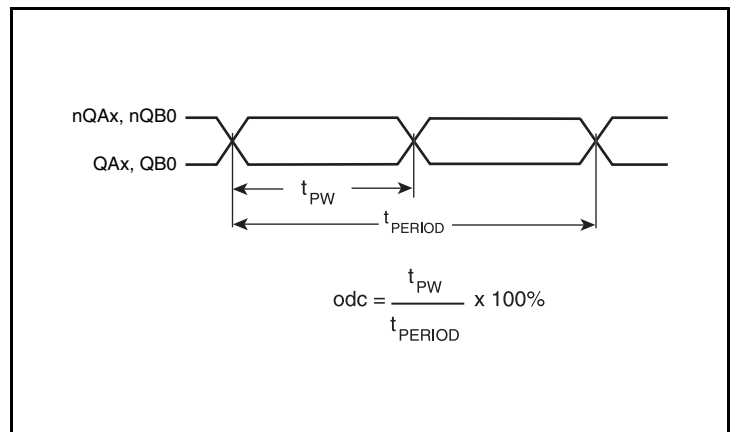

Output Duty Cycle/Pulse Width/Period

Parameter Measurement Information, continued

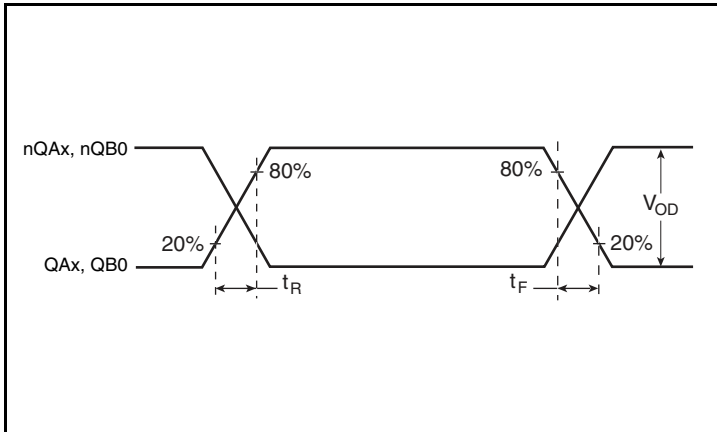

Output Rise/Fall Time

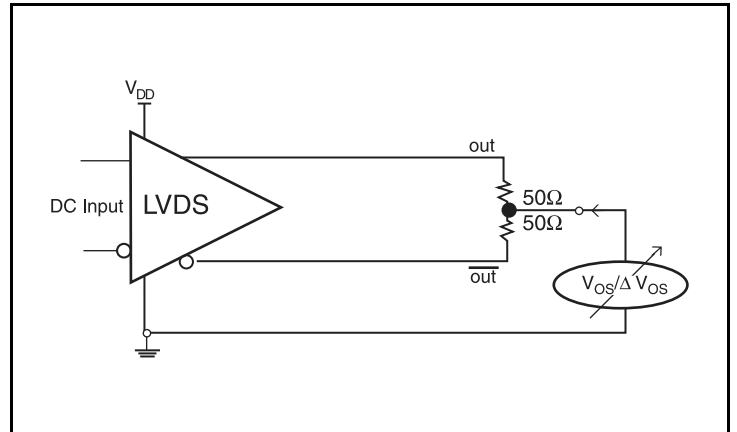

Offset Voltage Setup

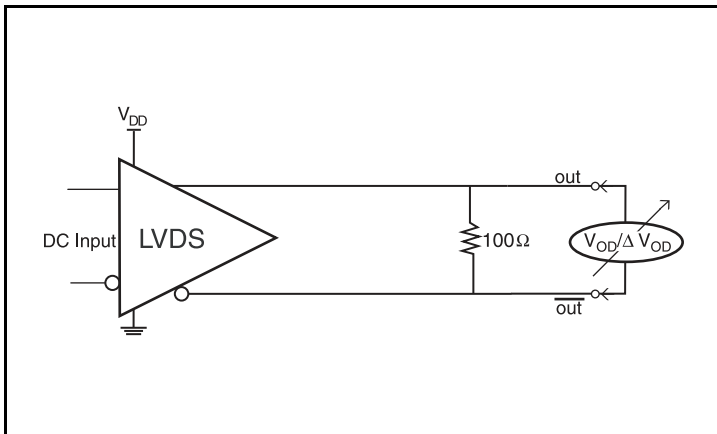

Differential Output Voltage Setup



## Application Information

### Power Supply Filtering Technique

As in any high speed analog circuitry, the power supply pins are vulnerable to random noise. To achieve optimum jitter performance, power supply isolation is required. The ICS874003-05 provides separate power supplies to isolate any high switching noise from the outputs to the internal PLL.  $V_{DD}$ ,  $V_{DDA}$  and  $V_{DDO}$  should be individually connected to the power supply plane through vias, and  $0.01\mu\text{F}$  bypass capacitors should be used for each pin. *Figure 1* illustrates this for a generic  $V_{DD}$  pin and also shows that  $V_{DDA}$  requires that an additional  $10\Omega$  resistor along with a  $10\mu\text{F}$  bypass capacitor be connected to the  $V_{DDA}$  pin.

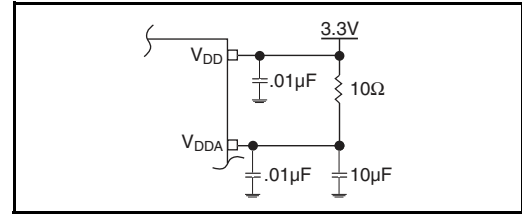

Figure 1. Power Supply Filtering

### Wiring the Differential Input to Accept Single-Ended Levels

*Figure 2* shows how a differential input can be wired to accept single ended levels. The reference voltage  $V_1 = V_{CC}/2$  is generated by the bias resistors  $R1$  and  $R2$ . The bypass capacitor ( $C1$ ) is used to help filter noise on the DC bias. This bias circuit should be located as close to the input pin as possible. The ratio of  $R1$  and  $R2$  might need to be adjusted to position the  $V_1$  in the center of the input voltage swing. For example, if the input clock swing is  $2.5\text{V}$  and  $V_{CC} = 3.3\text{V}$ ,  $R1$  and  $R2$  value should be adjusted to set  $V_1$  at  $1.25\text{V}$ . The values below are for when both the single ended swing and  $V_{CC}$  are at the same voltage. This configuration requires that the sum of the output impedance of the driver ( $R_o$ ) and the series resistance ( $R_s$ ) equals the transmission line impedance. In addition, matched termination at the input will attenuate the signal in half. This can be done in one of two ways. First,  $R3$  and  $R4$  in parallel should equal the transmission line

impedance. For most  $50\Omega$  applications,  $R3$  and  $R4$  can be  $100\Omega$ . The values of the resistors can be increased to reduce the loading for slower and weaker LVCMOS driver. When using single-ended signaling, the noise rejection benefits of differential signaling are reduced. Even though the differential input can handle full rail LVCMOS signaling, it is recommended that the amplitude be reduced. The datasheet specifies a lower differential amplitude, however this only applies to differential signals. For single-ended applications, the swing can be larger, however  $V_{IL}$  cannot be less than  $-0.3\text{V}$  and  $V_{IH}$  cannot be more than  $V_{CC} + 0.3\text{V}$ . Though some of the recommended components might not be used, the pads should be placed in the layout. They can be utilized for debugging purposes. The datasheet specifications are characterized and guaranteed by using a differential signal.

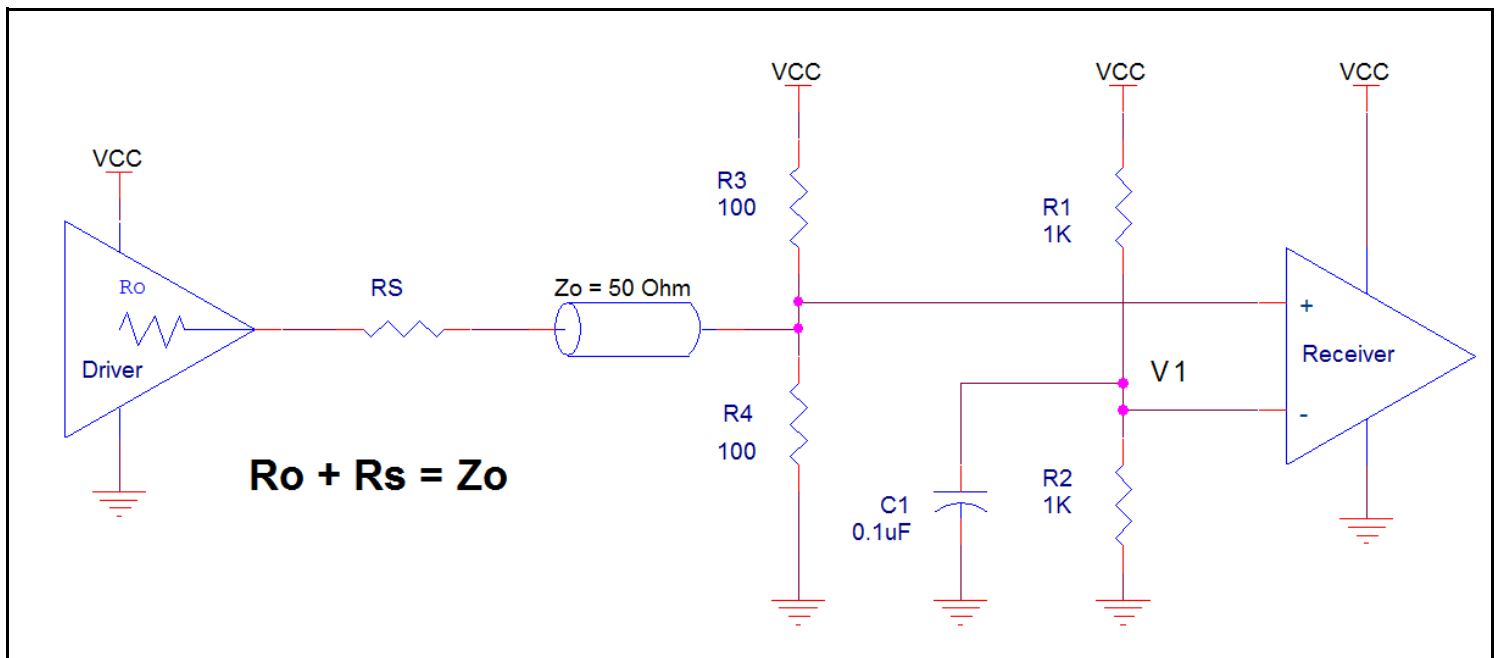
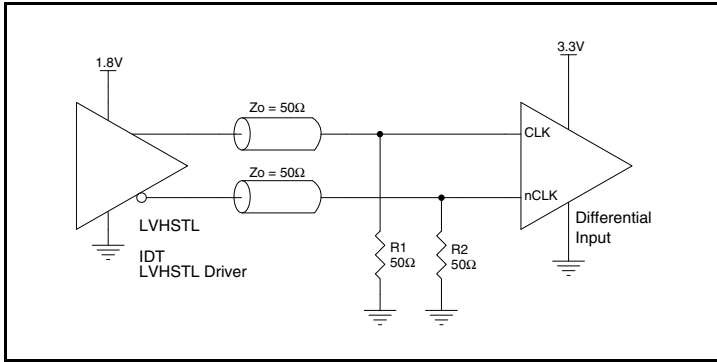

Figure 2. Recommended Schematic for Wiring a Differential Input to Accept Single-ended Levels

## Differential Clock Input Interface

The CLK /nCLK accepts LVDS, LVPECL, LVHSTL, SSTL, HCSL and other differential signals. Both signals must meet the  $V_{PP}$  and  $V_{CMR}$  input requirements. *Figures 3A to 3F* show interface examples for the CLK/nCLK input driven by the most common driver types. The input interfaces suggested here are examples only. Please consult with the

vendor of the driver component to confirm the driver termination requirements. For example, in Figure 3A, the input termination applies for IDT open emitter LVHSTL drivers. If you are using an LVHSTL driver from another vendor, use their termination recommendation.



**Figure 3A.** CLK/nCLK Input Driven by an IDT Open Emitter LVHSTL Driver

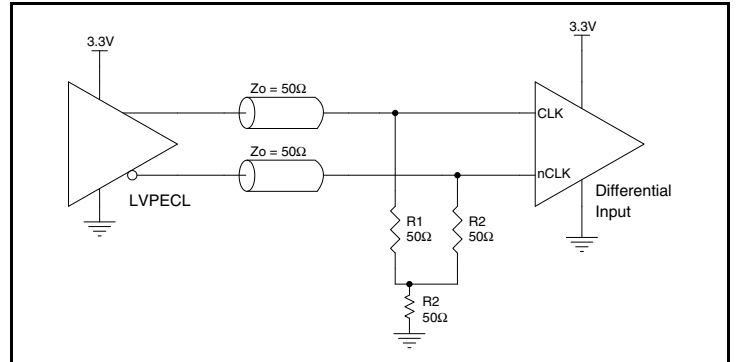

**Figure 3B.** CLK/nCLK Input Driven by a 3.3V LVPECL Driver

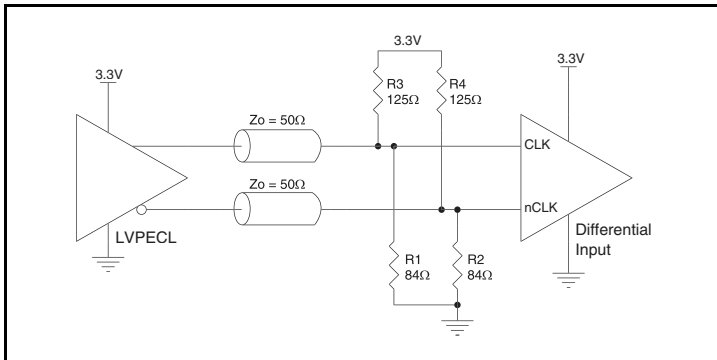

**Figure 3C.** CLK/nCLK Input Driven by a 3.3V LVPECL Driver

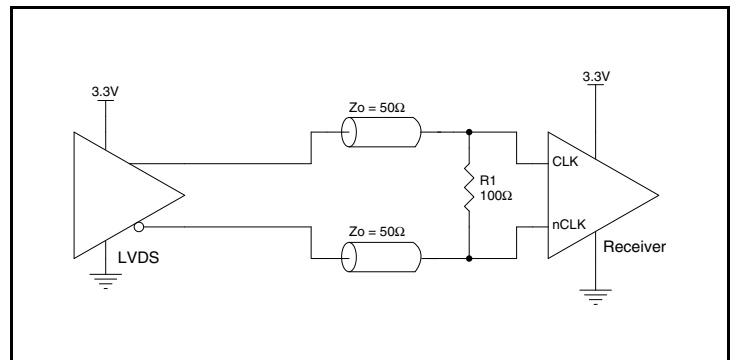

**Figure 3D.** CLK/nCLK Input Driven by a 3.3V LVDS Driver

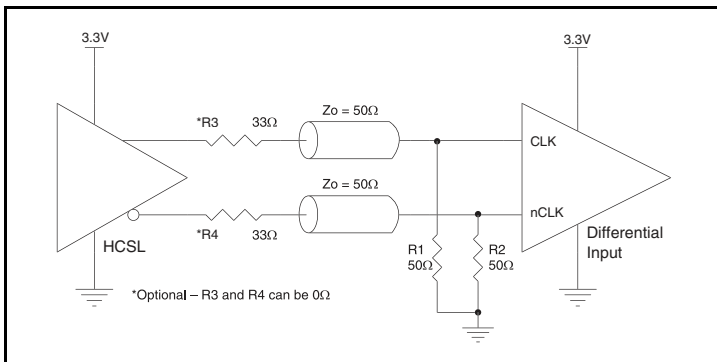

**Figure 3E.** CLK/nCLK Input Driven by a 3.3V HCSL Driver

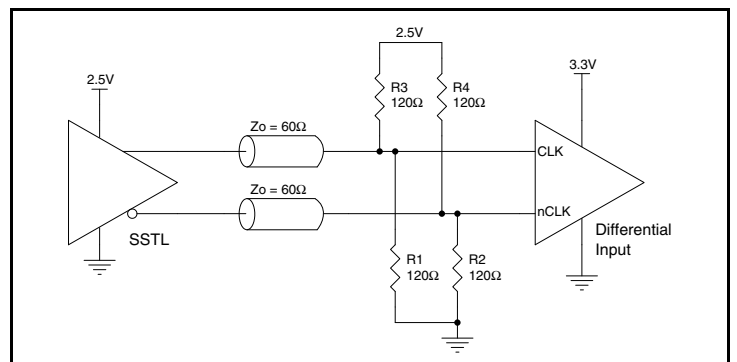

**Figure 3F.** CLK/nCLK Input Driven by a 2.5V SSTL Driver

## Recommendations for Unused Input and Output Pins

### Inputs:

#### LVCMOS Control Pins

All control pins have internal pullups or pulldowns; additional resistance is not required but can be added for additional protection. A 1kΩ resistor can be used.

### Outputs:

#### LVDS Outputs

All unused LVDS output pairs can be either left floating or terminated with 100Ω across. If they are left floating, there should be no trace attached.

## LVDS Driver Termination

For a general LVDS interface, the recommended value for the termination impedance ( $Z_T$ ) is between 90Ω and 132Ω. The actual value should be selected to match the differential impedance ( $Z_0$ ) of your transmission line. A typical point-to-point LVDS design uses a 100Ω parallel resistor at the receiver and a 100Ω differential transmission-line environment. In order to avoid any transmission-line reflection issues, the components should be surface mounted and must be placed as close to the receiver as possible. IDT offers a full line of LVDS compliant devices with two types of output structures: current source and voltage source. The standard

termination schematic as shown in *Figure 4A* can be used with either type of output structure. *Figure 4B*, which can also be used with both output types, is an optional termination with center tap capacitance to help filter common mode noise. The capacitor value should be approximately 50pF. If using a non-standard termination, it is recommended to contact IDT and confirm if the output structure is current source or voltage source type. In addition, since these outputs are LVDS compatible, the input receiver's amplitude and common-mode input range should be verified for compatibility with the output.

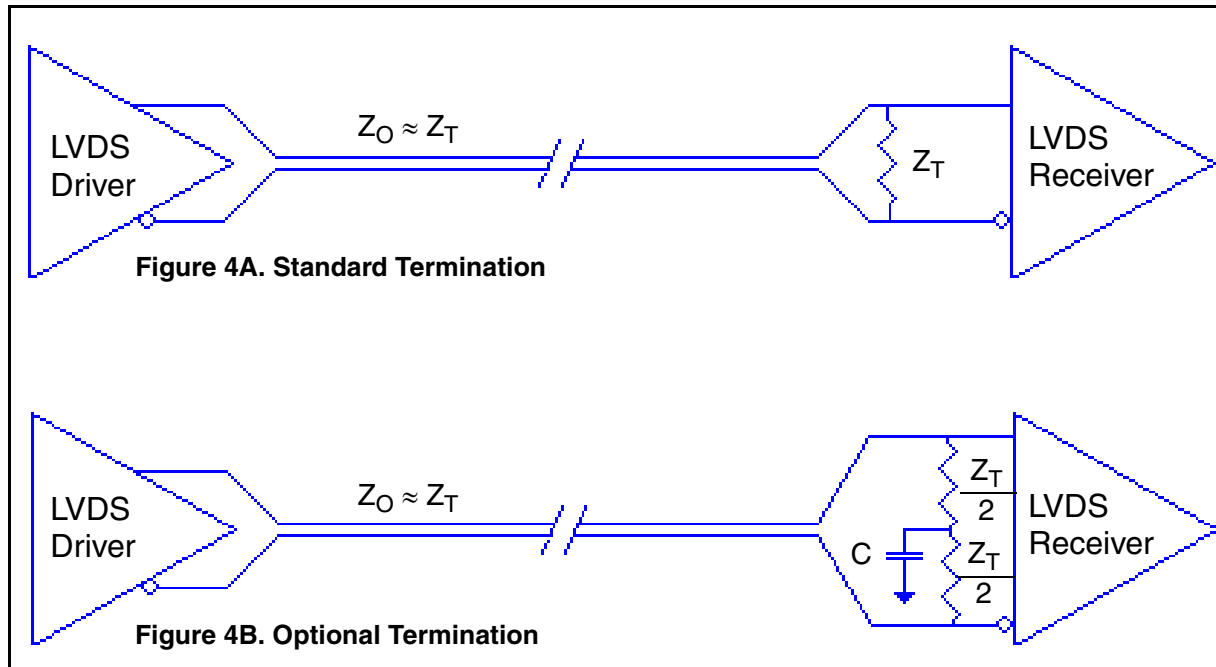

### LVDS Termination

## Schematic Example

Figure 5 shows an example of ICS874003-05 application schematic. In this example, the device is operated at  $V_{DD} = 3.3V$ . The decoupling capacitors should be located as close as possible to the power pin.

Two examples of LVDS terminations are shown in this schematic. The input is driven either by a 3.3V LVPECL driver or a 3.3V LVCMOS.

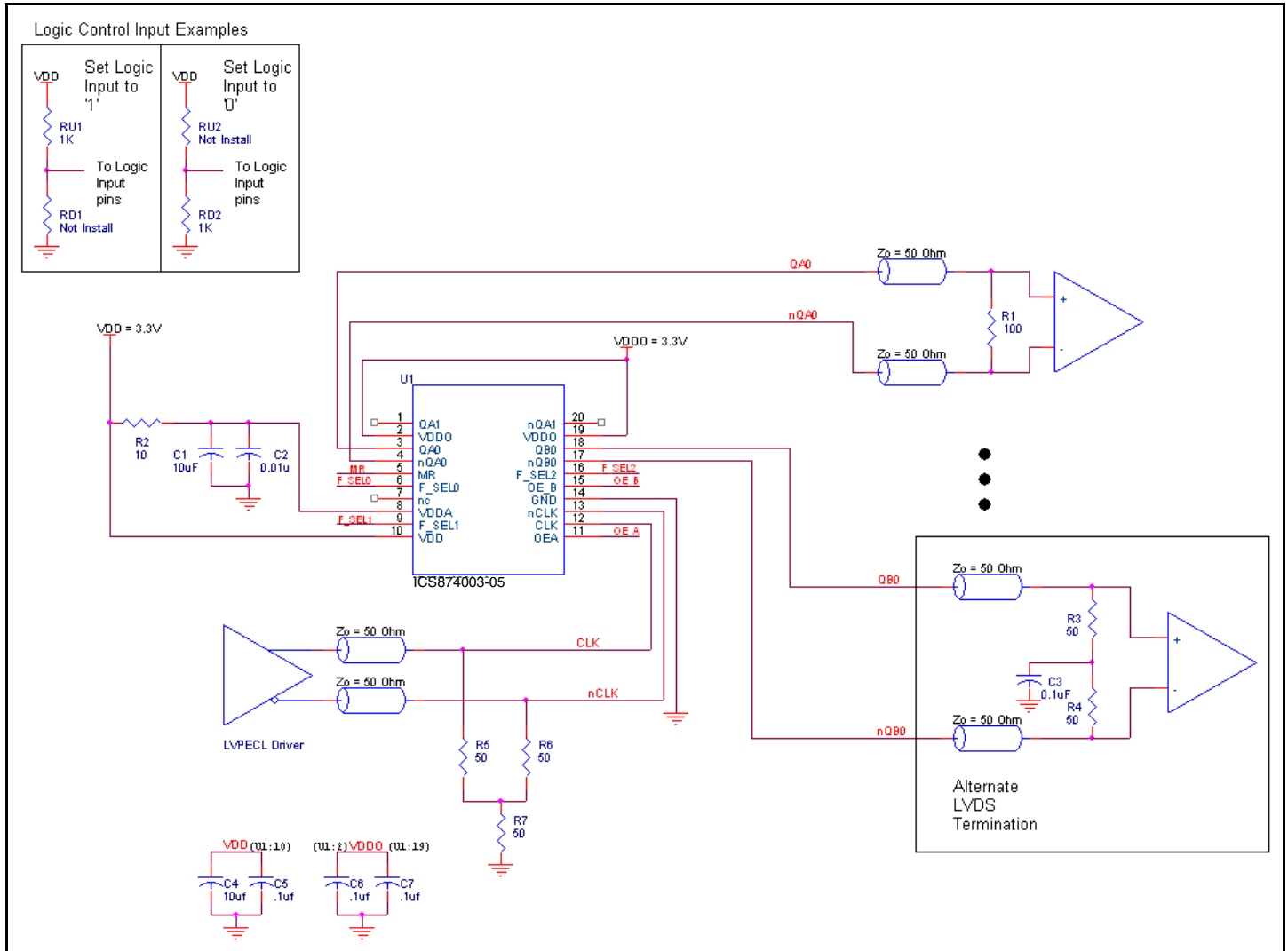

Figure 5. ICS874003-05 Schematic Example

## PCI Express Application Note

PCI Express jitter analysis methodology models the system response to reference clock jitter. The block diagram below shows the most frequently used *Common Clock Architecture* in which a copy of the reference clock is provided to both ends of the PCI Express Link.

In the jitter analysis, the transmit (Tx) and receive (Rx) serdes PLLs are modeled as well as the phase interpolator in the receiver. These transfer functions are called H1, H2, and H3 respectively. The overall system transfer function at the receiver is:

$$Ht(s) = H3(s) \times [H1(s) - H2(s)]$$

The jitter spectrum seen by the receiver is the result of applying this system transfer function to the clock spectrum X(s) and is:

$$Y(s) = X(s) \times H3(s) \times [H1(s) - H2(s)]$$

In order to generate time domain jitter numbers, an inverse Fourier Transform is performed on  $X(s) \times H3(s) \times [H1(s) - H2(s)]$ .

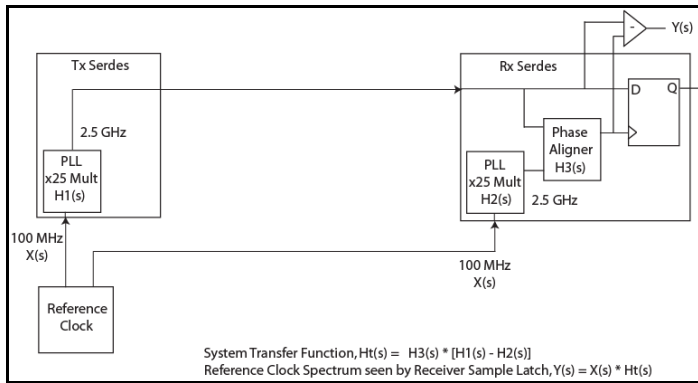

### PCI Express Common Clock Architecture

For **PCI Express Gen 1**, one transfer function is defined and the evaluation is performed over the entire spectrum: DC to Nyquist (e.g. for a 100MHz reference clock: 0Hz – 50MHz) and the jitter result is reported in peak-peak.

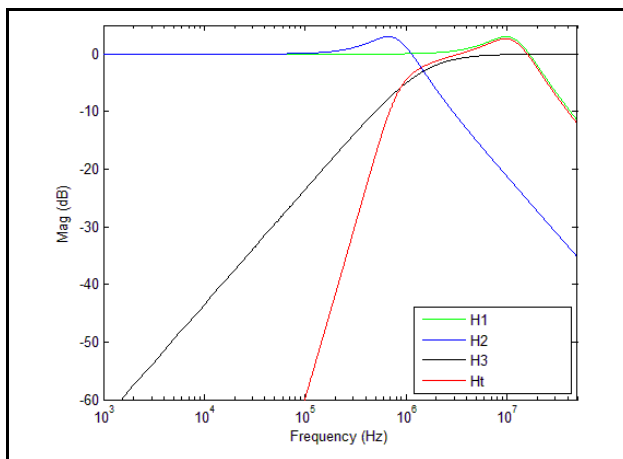

### PCI Express Gen 1 Magnitude of Transfer Function

For **PCI Express Gen 2**, two transfer functions are defined with 2 evaluation ranges and the final jitter number is reported in rms. The two evaluation ranges for PCI Express Gen 2 are 10kHz – 1.5MHz (Low Band) and 1.5MHz – Nyquist (High Band). The plots show the individual transfer functions as well as the overall transfer function Ht.

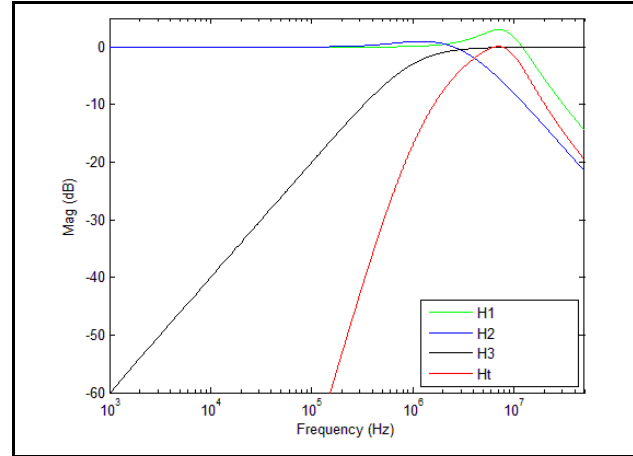

### PCIe Gen 2A Magnitude of Transfer Function

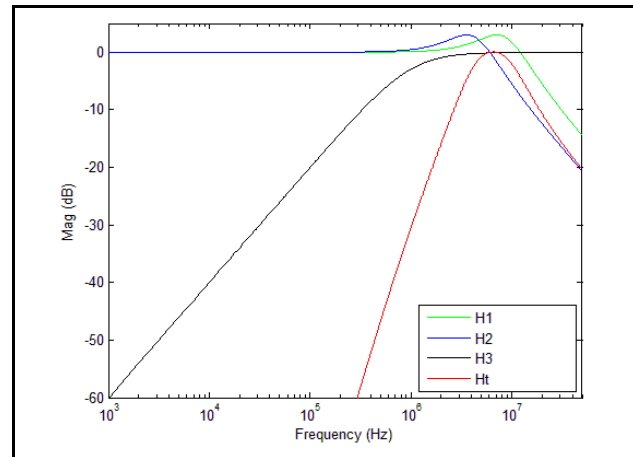

### PCIe Gen 2B Magnitude of Transfer Function

For **PCI Express Gen 3**, one transfer function is defined and the evaluation is performed over the entire spectrum. The transfer function parameters are different from Gen 1 and the jitter result is reported in RMS.

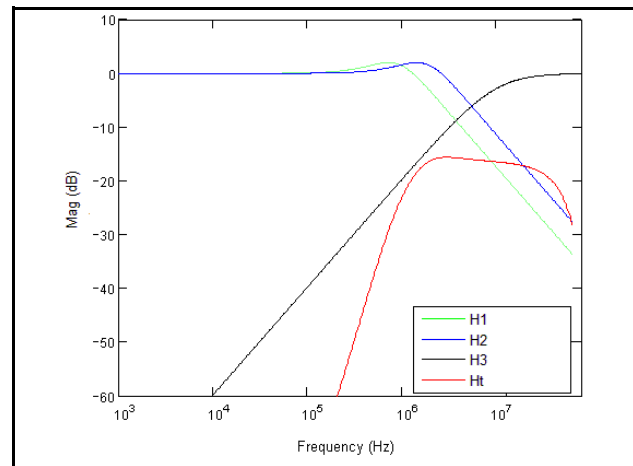

### PCIe Gen 3 Magnitude of Transfer Function

For a more thorough overview of PCI Express jitter analysis methodology, please refer to IDT Application Note *PCI Express Reference Clock Requirements*.

## Power Considerations

This section provides information on power dissipation and junction temperature for the ICS874003-05. Equations and example calculations are also provided.

### 1. Power Dissipation.

The total power dissipation for the ICS74003-05 is the sum of the core power plus the analog power plus the power dissipated in the load(s). The following is the power dissipation for  $V_{DD} = 3.3V + 5\% = 3.465V$ , which gives worst case results.

- Power (core)<sub>MAX</sub> =  $V_{DD\_MAX} * (I_{DD\_MAX} + I_{DDA\_MAX}) = 3.465V * (75mA + 16mA) = \mathbf{315.315mW}$
- Power (outputs)<sub>MAX</sub> =  $V_{DDO\_MAX} * I_{DDO\_MAX} = 3.465V * 75mA = \mathbf{259.875mW}$

**Total Power<sub>-MAX</sub> = 315.3mW + 259.9mW = 575.2mW**

### 2. Junction Temperature.

Junction temperature,  $T_j$ , is the temperature at the junction of the bond wire and bond pad and directly affects the reliability of the device. The maximum recommended junction temperature for devices is 125°C.

The equation for  $T_j$  is as follows:  $T_j = \theta_{JA} * Pd\_total + T_A$

$T_j$  = Junction Temperature

$\theta_{JA}$  = Junction-to-Ambient Thermal Resistance

$Pd\_total$  = Total Device Power Dissipation (example calculation is in section 1 above)

$T_A$  = Ambient Temperature

In order to calculate junction temperature, the appropriate junction-to-ambient thermal resistance  $\theta_{JA}$  must be used. Assuming no air flow and a multi-layer board, the appropriate value is 86.7°C/W per Table 6 below.

Therefore,  $T_j$  for an ambient temperature of 70°C with all outputs switching is:

$$70^\circ\text{C} + 0.575\text{W} * 86.7^\circ\text{C}/\text{W} = 119.9^\circ\text{C}. \text{ This is below the limit of } 125^\circ\text{C}.$$

This calculation is only an example.  $T_j$  will obviously vary depending on the number of loaded outputs, supply voltage, air flow and the type of board.

**Table 6. Thermal Resistance  $\theta_{JA}$  for 20-Lead TSSOP, Forced Convection**

Meters per Second	$\theta_{JA}$ by Velocity		
	0	1	2.5
Multi-Layer PCB, JEDEC Standard Test Boards	86.7°C/W	82.4°C/W	80.2°C/W

## Reliability Information

Table 7.  $\theta_{JA}$  vs. Air Flow Table for a 20-Lead TSSOP

$\theta_{JA}$ by Velocity			
Meters per Second	0	1	2.5
Multi-Layer PCB, JEDEC Standard Test Boards	86.7°C/W	82.4°C/W	80.2°C/W

## Transistor Count

The transistor count for ICS874003-05 is: 1418

## Package Outline and Package Dimensions

Package Outline - G Suffix for 20-Lead TSSOP

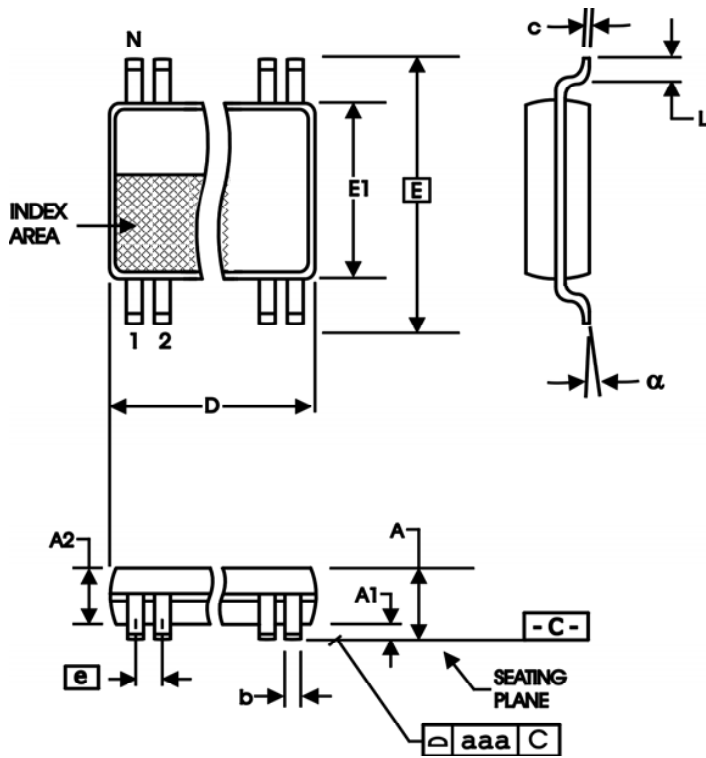

Table 8. Package Dimensions

All Dimensions in Millimeters		
Symbol	Minimum	Maximum
N	20	
A		1.20
A1	0.05	0.15
A2	0.80	1.05
b	0.19	0.30
c	0.09	0.20
D	6.40	6.60
E	6.40 Basic	
E1	4.30	4.50
e	0.65 Basic	
L	0.45	0.75
$\alpha$	0°	8°
aaa		0.10

Reference Document: JEDEC Publication 95, MO-153

## Ordering Information

Table 9. Ordering Information

Part/Order Number	Marking	Package	Shipping Packaging	Temperature
874003BG-05LF	ICS74003B05L	"Lead-Free" 20-Lead TSSOP	Tube	0°C to 70°C
874003BG-05LFT	ICS74003B05L	"Lead-Free" 20-Lead TSSOP	Tape & Reel	0°C to 70°C



## Revision History Sheet

Rev	Table	Page	Description of Change	Date
B	T9	17	Corrected marking information in ordering table to accurately match the ABS document	11/09/11
B	T9	9 11 13 16	Updated the 'Wiring the Differential Input to Accept Single-Ended Levels' Note. Updated the 'LVDS Driver Termination' Note. Updated the 'PCI Express Application' Note. Added ICS prefix to marking information in the Ordering Table. Deleted quantity from Tape and Reel.	3/21/14



## IMPORTANT NOTICE AND DISCLAIMER

RENESAS ELECTRONICS CORPORATION AND ITS SUBSIDIARIES (“RENESAS”) PROVIDES TECHNICAL SPECIFICATIONS AND RELIABILITY DATA (INCLUDING DATASHEETS), DESIGN RESOURCES (INCLUDING REFERENCE DESIGNS), APPLICATION OR OTHER DESIGN ADVICE, WEB TOOLS, SAFETY INFORMATION, AND OTHER RESOURCES “AS IS” AND WITH ALL FAULTS, AND DISCLAIMS ALL WARRANTIES, EXPRESS OR IMPLIED, INCLUDING, WITHOUT LIMITATION, ANY IMPLIED WARRANTIES OF MERCHANTABILITY, FITNESS FOR A PARTICULAR PURPOSE, OR NON-INFRINGEMENT OF THIRD PARTY INTELLECTUAL PROPERTY RIGHTS.

These resources are intended for developers skilled in the art designing with Renesas products. You are solely responsible for (1) selecting the appropriate products for your application, (2) designing, validating, and testing your application, and (3) ensuring your application meets applicable standards, and any other safety, security, or other requirements. These resources are subject to change without notice. Renesas grants you permission to use these resources only for development of an application that uses Renesas products. Other reproduction or use of these resources is strictly prohibited. No license is granted to any other Renesas intellectual property or to any third party intellectual property. Renesas disclaims responsibility for, and you will fully indemnify Renesas and its representatives against, any claims, damages, costs, losses, or liabilities arising out of your use of these resources. Renesas' products are provided only subject to Renesas' Terms and Conditions of Sale or other applicable terms agreed to in writing. No use of any Renesas resources expands or otherwise alters any applicable warranties or warranty disclaimers for these products.

(Disclaimer Rev.1.0 Mar 2020)

### Corporate Headquarters

TOYOSU FORESIA, 3-2-24 Toyosu,  
Koto-ku, Tokyo 135-0061, Japan  
[www.renesas.com](http://www.renesas.com)

### Contact Information

For further information on a product, technology, the most up-to-date version of a document, or your nearest sales office, please visit:  
[www.renesas.com/contact/](http://www.renesas.com/contact/)

### Trademarks

Renesas and the Renesas logo are trademarks of Renesas Electronics Corporation. All trademarks and registered trademarks are the property of their respective owners.