

REVISIONS			
REV	DESCRIPTION, ECN, EAR NO.	DATE	APP'D
A	PROPOSAL	NOV28/16	L.CHAN
B	CHANGE SHIELD TAIL PLAINING	MAY17/17	L.CHAN

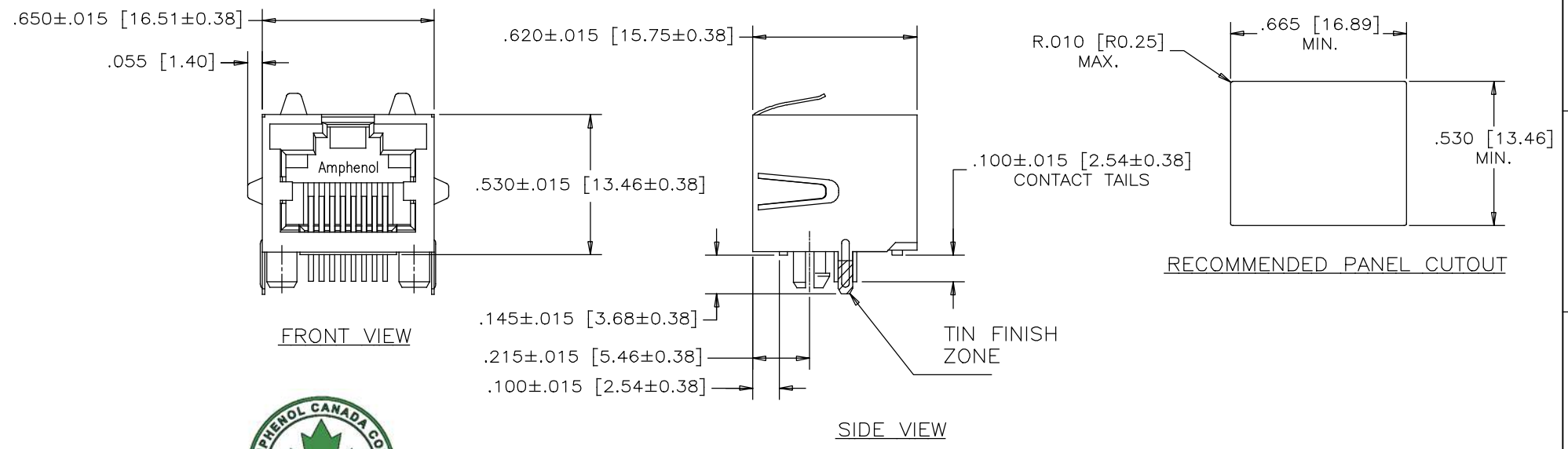

1. MATERIALS:
 PLASTIC HOUSING: HIGH TEMPERATURE THERMOPLASTIC
 FLAMMABILITY RATING UL 94V-0
- CONTACTS: PHOSPHOR BRONZE
 PLATING: GOLD PLATING ON MATING SURFACES
 [SEE PART NUMBER FOR THICKNESS]
 50 μ" [1.27 MICRONS]
 MIN. NICKEL UNDERPLATE
 100 μ" [2.54 MICRONS]
 MIN. MATTE TIN ON CONTACT TAILS.
- SHIELD: STAINLESS STEEL WITH TIN FINISH ON SOLDER TAIL

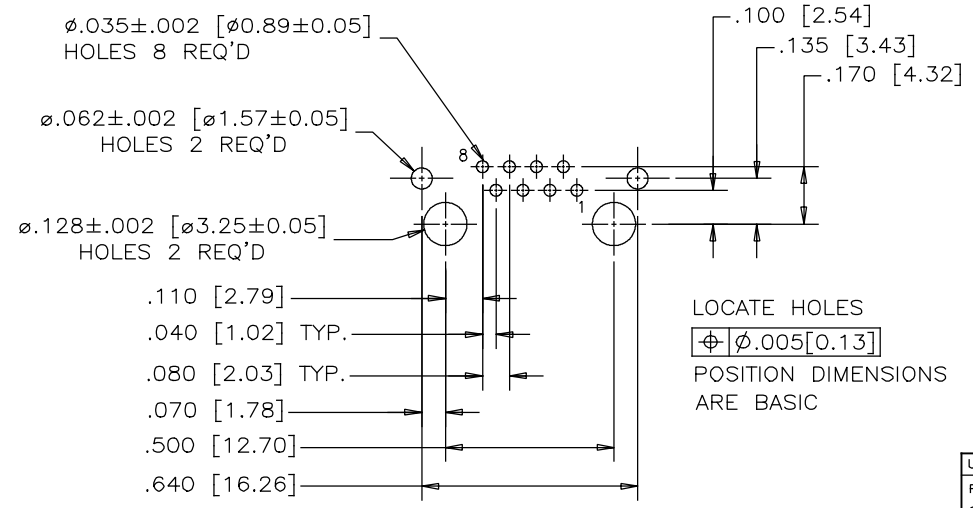

PART NUMBER: RJHSE-X480

- GOLD PLATING
- E=RJ45 FLAT CONTACT 6u"
 - G=RJ45 FLAT CONTACT 15u"
 - J=RJ45 FLAT CONTACT 30u"
 - 5=RJ45 FLAT CONTACT 50u"
 - 0=RJ45 FLAT CONTACT 1~3u"

RECOMMENDED P.C.B. LAYOUT
 (COMPONENT SIDE OF BOARD)

UNLESS SPECIFIED OTHERWISE		DRAWN	W.QIU	DATE	NOV28/16	Amphenol Canada Corp. www.amphenolcanada.com
PRIMARY UNITS	INCH	CHECKED	LAWRENCE C	DATE	NOV28/16	
SECONDARY UNITS	MILLIMETER	M.E. APP'D				TITLE
REFERENCE IN PARENTHESES	Q.A. APP'D					RJ45, MODULAR JACK, 8 POSITION, 8 CONTACTS, SHIELDED, WITHOUT LEDs - RoHS COMPLIANT
GENERAL TOLERANCES	DWG APPR.					DWG. NO.
1 DECIMAL PLACE ±0.025	ENG. REL. NO.					P-RJHSE-X480
2 DECIMAL PLACES ±0.020	REF.					REV B
3 DECIMAL PLACES ±0.015	THIRD ANGLE PROJECTION					CODE ID NO. 03554 DWG SIZE: c SCALE: N/A SHEET 1 OF 1
ANGULAR DEGREES ±1.0°	DO NOT SCALE DRAWING					