

# CT0805HQF Series

From 2.5 nH to 51 nH

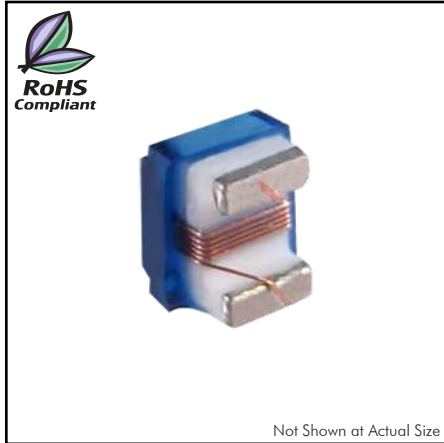

## SPECIFICATIONS

Please specify tolerance code when ordering.  
 CT0805HQF-16N\_ ← G = ±2%, J = ±5% K = ±10%  
 \*J or K only

Part Number	Inductance (nH)	L Test Freq. (MHz)	Q Fact. Min.	Q Test Freq. (MHz)	SRF Typ. (MHz)	DCR Max. (Ω)	Irms Max. (mA)
CT0805HQF-2N5_*	2.5	250	80	1500	6000	0.020	1600
CT0805HQF-5N6_*	5.6	250	98	1500	6000	0.035	1600
CT0805HQF-6N2_*	6.2	250	88	1000	4750	0.035	1600
CT0805HQF-12N_*	12	250	80	1000	3000	0.045	1600
CT0805HQF-16N_	16	250	72	500	2950	0.060	1500
CT0805HQF-18N_	18	250	75	500	2550	0.060	1400
CT0805HQF-20N_	20	250	70	500	2050	0.055	1400
CT0805HQF-27N_	27	250	75	500	2000	0.070	1300
CT0805HQF-30N_	30	250	65	500	1950	0.095	1200
CT0805HQF-39N_	39	250	65	500	1600	0.095	1100
CT0805HQF-48N_	48	200	65	500	1400	0.110	1200
CT0805HQF-51N_	51	200	65	500	1400	0.120	1000

## PHYSICAL DIMENSIONS

Size	A Max.	B Max.	C Max.	D	E	F	G
mm	2.29	1.78	1.56	0.50	1.27	0.44	1.27
inches	0.090	0.070	0.061	0.020	0.050	0.017	0.050

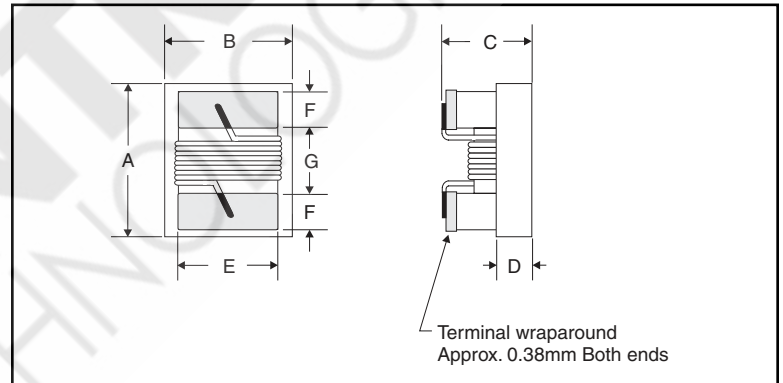

## CHARACTERISTICS

**Description:** SMD wire-wound chip inductor. (High Q)

**Applications:** LC resonant circuits such as oscillator and signal generators, impedance matching, circuit isolation, RF filters, disk drives and computer peripherals, audio and video equipment, TV, radio and telecommunication equipment.

**Operating Temperature:** -40°C to +125°C

**Inductance Tolerance:** ±2%, ±5%, ±10%

**Testing:** Inductance and Q tested on an HP4287A at specified frequency.

**Packaging:** Tape & Reel.

**Marking:** Color dot.

**Miscellaneous:** **RoHS Compliant.**

**Additional Information:** Additional electrical & physical information available upon request.

**Samples available. See website for ordering information.**

## PAD LAYOUT

