

REVISIONS					
P	LTR	DESCRIPTION	DATE	DWN	APVD
A1		ECR-20-004655	29SEP2020	RK	SBH

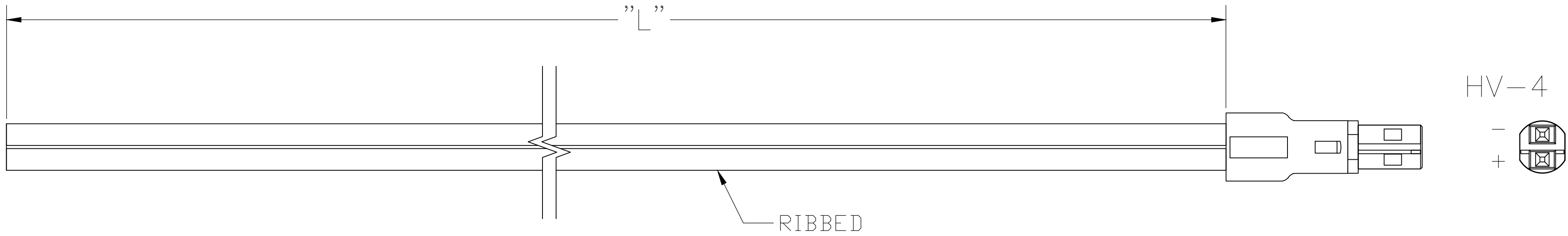

WIRING SCHEDULE		
	SIDE	PLUG
+	RIBBED	1
-	SMOOTH	2

1. PACKAGING ACC. TO TE SPEC.107-18032  
BUNDLE EVERY 25 ASSEMBLIES WITH A RUBBER BAND
2. ELECTRICAL TEST CONTAINING "SHORT CIRCUIT TEST, CONTINUITY AND ACCURATE CAVITY ASSIGNMENT TEST" ACC. TO TE-SPEC.108-18857, SUBSECTION 3.1.1

3 WIRING SCHEDULE AS SHOWN

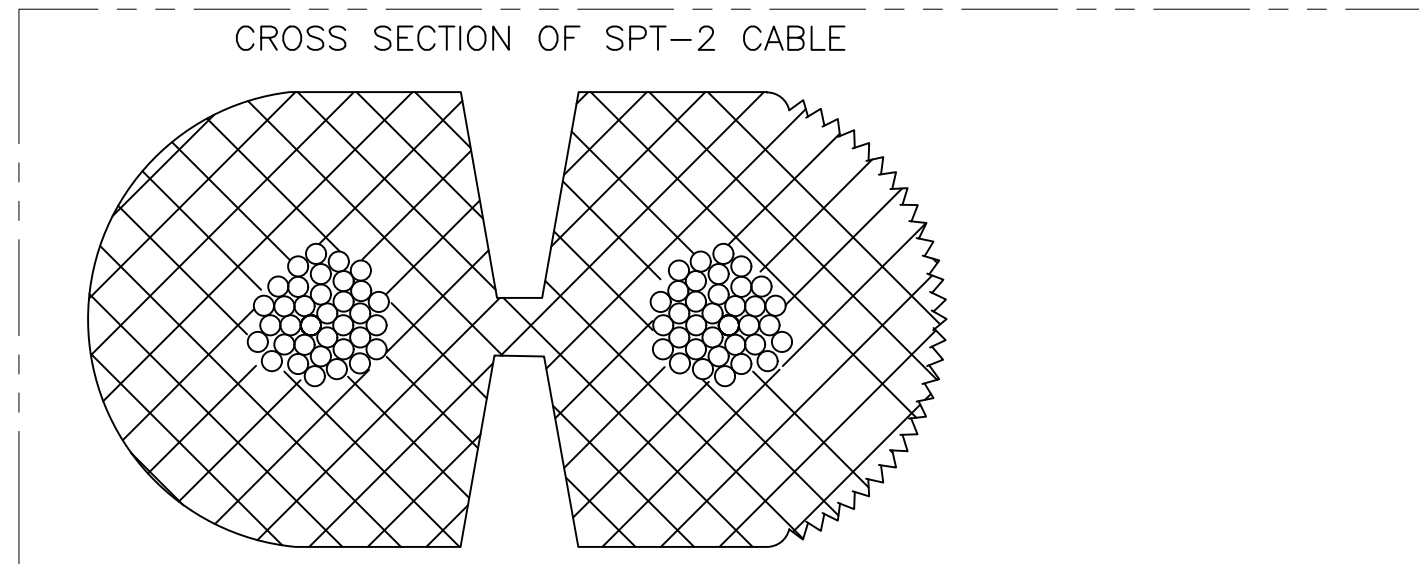

OBSOLETE	16.0 FT	±3.84	2181194-8
	14.0 FT	±3.36	2181194-7
	12.0 FT	±2.88	2181194-6
	10.0 FT	±2.4	2181194-5
	8.0 FT	±1.92	2181194-4
	6.0 FT	±1.44	2181194-3
	4.0 FT	±.96	2181194-2
	2.0 FT	±.48	2181194-1
	"L"	TOLERANCES [INCHES]	TE P/N

THIS DRAWING IS A CONTROLLED DOCUMENT.		DWN	17/JUN/11	TE Connectivity	
		E.C. CLAYBAUGH			
		CHK	13/JUL/11	NAME CABLE ASSEMBLY, NECTOR, HV-4, PLUG - PIGTAIL	
		P. BECKER			
		APVD	01/AUG/11	SIZE	
		P. BECKER			
		PRODUCT SPEC		CAGE CODE	DRAWING NO
		APPLICATION SPEC		A2	00779
		WEIGHT	-	C=2181194	
		CUSTOMER DRAWING		SCALE	N.T.S.
				SHEET	1 OF 1
				REV	A1