

## Mechanical Dimensions: Inches [mm]

Tolerances  $\pm 0.012$  [0.3] Unless Otherwise Specified

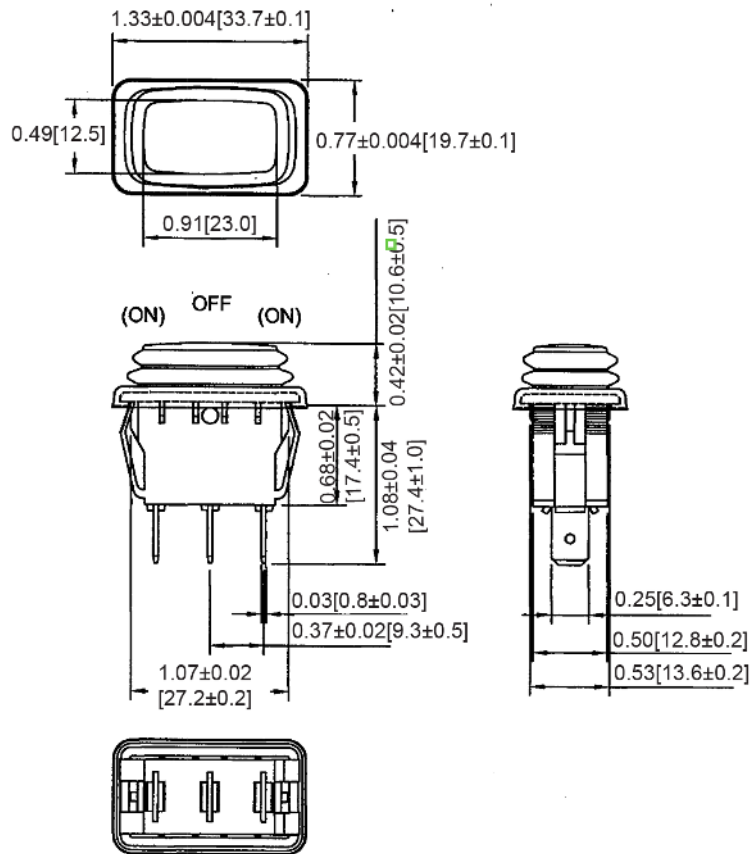

## Mounting Hole

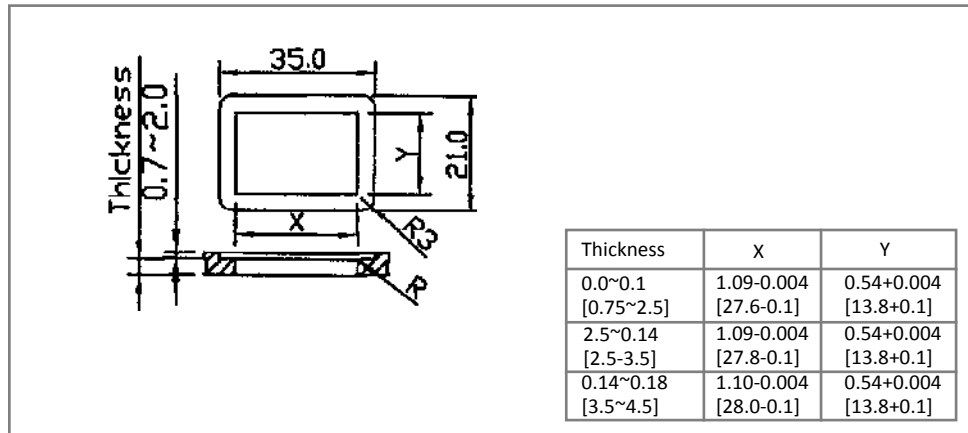

## Circuit Diagram

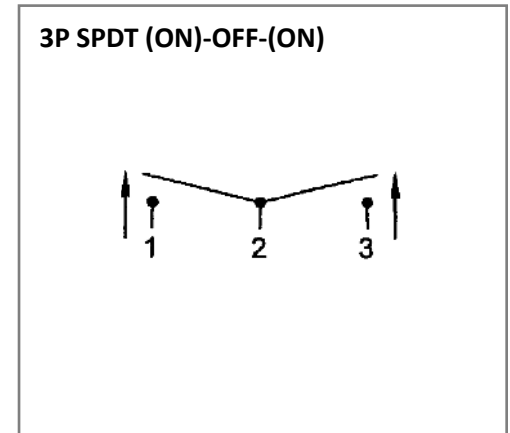

## Electrical Specifications

Rating	16(4)A 125/250V DC
Contact Resistance	50m ohm Max.
Insulation Resistance	DC 500V 100M ohm Min
Dielectric Strength	AC 1500V 1 minute
Operation Temperature	-25°C~85°C

## Material Specifications

Frame	Black, Nylon 66
Actuator	Black, Nylon 66 +33%GF
Waterproof Rubber	Black, Silicone
Printed	White, Hot Stamping
	IP65

**Rev**    **Date of issue**    **Revision Notes**

**Designed**    **Approved**

A	03-19-2021	Initial Drawing	RC	OF
---	------------	-----------------	----	----