

CM2545X171B-10

PHYSICAL DIMENSIONS:

A	6.30	[.248]	±	0.10	[.004]
B	11.38	[.448]	±	0.18	[.007]
C	9.32	[.367]	±	0.18	[.007]
D	7.62	[.300]	±	0.10	[.004]
E	2.54	[.100]	±	0.13	[.005]
T ₁	3.43	[.135]	±	0.25	[.010]
T ₂	0.64	[.025]	±	TYP.	

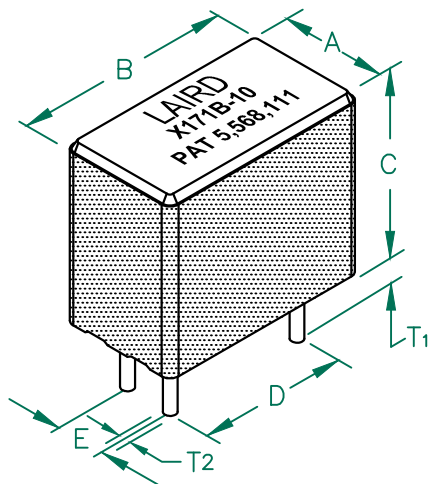

ELECTRICAL CHARACTERISTICS:			
Z @ 100MHz (Ω)	DCR (Ω)	Rated Current	
Nominal	170		
Minimum	128		
Maximum	212	0.01	10,000 mA

- NOTES: UNLESS OTHERWISE SPECIFIED
1. BULK PACKED, 1260 per CASE.
 2. COMPONENTS SHOULD BE ADEQUATELY PREHEATED BEFORE SOLDERING.
 3. TERMINATION FINISH IS 100% TIN.
 4. THIS PART HAS NO PIN POLARITY.
 5. OPERATION TEMPERATURE (INCLUDING SELF-HEATING): -40 ~ +125°C.

Z vs. FREQUENCY (C,O,N)

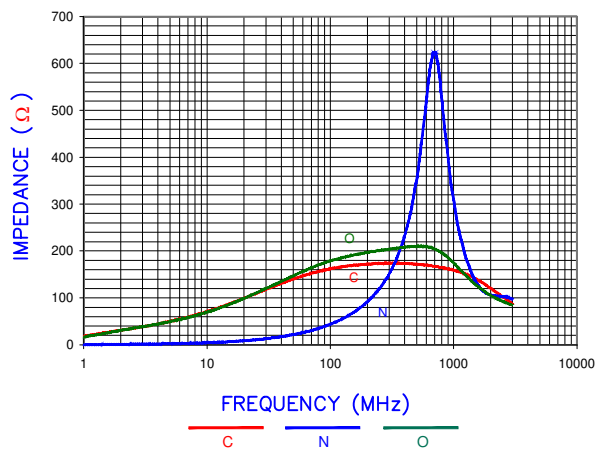

EQUIVALENT CIRCUIT

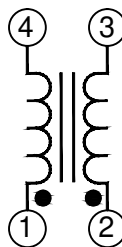

HOLE PATTERN FOR WAVE SOLDERING

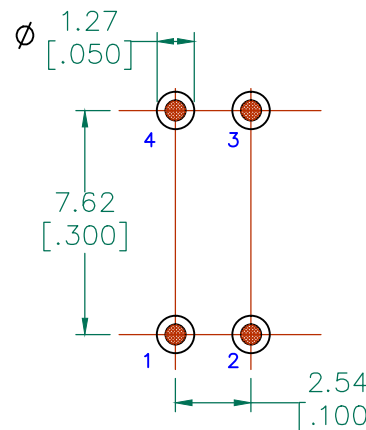

Z, R, XL vs. FREQUENCY

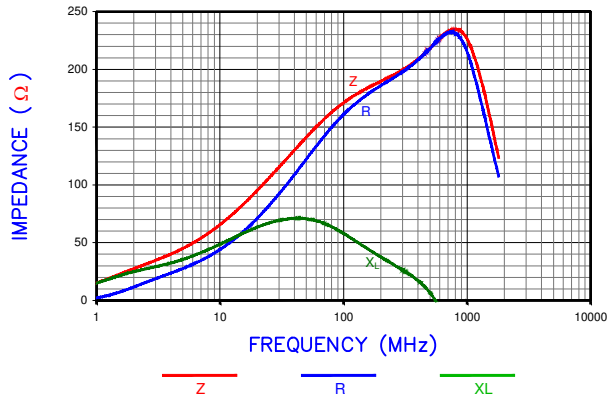

UNCONTROLLED DOCUMENT

DIMENSIONS ARE IN mm [INCHES]				This print is the property of Laird Tech. and is loaned in confidence subject to return upon request and with the understanding that no copies shall be made without the written consent of Laird Tech. All rights to design or invention are reserved.		Laird	
D	ADD NOTE 5	08/30/12	QIU	PROJECT/PART NUMBER:	REV	DRAWN BY:	
C	UPDATE COMPANY LOGO UPDATE ROHS SYMBOL AND KAPTON LABEL ADD EC	11/05/08	JRK	CM2545X171B-10	D	JRK	
B	UPDATE COMPANY LOGO	05/17/07	JRK	DATE: 5/26/04	SCALE: NTS	SHEET:	
A	ORIGINAL DRAFT	5/26/04	JRK	CAD #	TOOL #	1 of 2	
REV	DESCRIPTION	DATE		CM2545X171B-10-D-1	H0249-600		