

HOA7720/7730

Connectorized Transmissive Optoschmitt Sensor

FEATURES

- Direct TTL interface
- No interface circuits required
- Inverting logic
- Two device output options
- High resolution
- 0.118 in.(3.00 mm) slot width

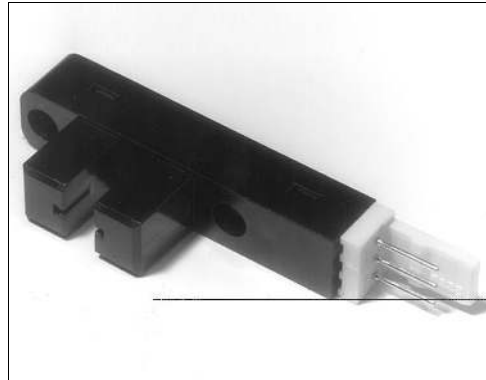

INFRA-85.TIF

DESCRIPTION

The HOA7720/7730 Series consists of an infrared emitting diode facing an Optoschmitt detector encased in a black thermoplastic housing. The photodetector consists of a photodiode, amplifier, voltage regulator and Schmitt trigger with two output configurations. The user can choose from available options of totem pole (HOA7720-M22) or open collector (HOA7730-M22) output. The totem pole output is well suited for applications which require fast transition times. The open collector allows the output of the sensor to interface with circuit elements driven by supply voltages other than Vcc supply. The inverting logic provides a high output when the optical path is interrupted, and a low output when the path is clear. The infrared emitting diode is biased internally eliminating the need for any external circuitry. Interconnection is simplified through the use of an integral Molex three pin connector.

Both emitter and detector have a 0.020 in.(.508 mm) x 0.070 in.(1.78 mm) vertical aperture. The narrow aperture is ideal for use in applications in which maximum rejection of ambient light is important, and maximum position resolution is desired. The HOA7720/7730 series employ plastic molded components. For additional component information see SEP8506, SDP8014 and SDP8314.

Housing material is opaque polycarbonate. Housings are soluble in chlorinated hydrocarbons and ketones. Recommended cleaning agents are methanol and isopropanol.

OUTLINE DIMENSIONS in inches (mm)

Tolerance 3 plc decimals ±0.010(0.25)
2 plc decimals ±0.020(0.51)

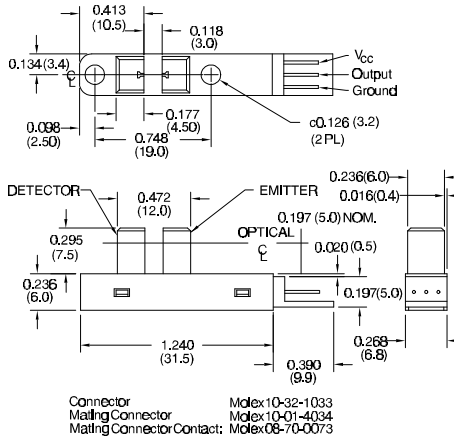

DIM_073.ds4

HOA7720-M22

Connectorized Transmissive Optoschmitt Sensor Totem-Pole Output

ELECTRICAL CHARACTERISTICS (-40°C to +70°C unless otherwise noted)

PARAMETER	SYMBOL	MIN	TYP	MAX	UNITS	TEST CONDITIONS
Operating Supply Voltage	V _{CC}	4.5	5.5		V	T _A =25°C
Supply Current	I _{CC}		40		mA	V _{CC} =5.5 V
Low Level Output Voltage	V _{OL}		0.4		V	V _{CC} =4.5 V, I _{OL} =12.8 mA
High Level Output Voltage	V _{OH}	2.4			V	V _{CC} =4.5 V, I _{OH} =-800 μA ⁽²⁾
Short Circuit Output Current	I _{OS}	-20		-100	mA	V _{CC} =5.25 V, Output=GND
Hysteresis ⁽³⁾	HYST		50		%	
Propagation Delay, Low-High, High-Low	t _{PLH} , t _{PHL}		5		μs	V _{CC} =5 V
Output Rise Time, Output Fall Time	t _r , t _f		70		ns	R _L =8 TTL Loads

Notes

1. It is recommended that a bypass capacitor, 0.1 μF typical, be added between V_{CC} and GND near the device in order to stabilize power supply line.
2. Output is HI when the optical path is interrupted.
3. Hysteresis is defined as the difference between the operating and release threshold intensities, expressed as a percentage of the operate threshold intensity.

ABSOLUTE MAXIMUM RATINGS

(25°C Free-Air Temperature unless otherwise noted)

Operating Temperature Range	-40°C to 70°C
Storage Temperature Range	-40°C to 85°C
Power Dissipation	220 mW
Supply Voltage	5.5 V
Supply Current	40 mA
Low Level Output Current	12.8 mA
Duration of Output Short to V _{CC} or Ground	1.0 sec

Honeywell reserves the right to make changes in order to improve design and supply the best products possible.

Honeywell

HOA7730-M22

Connectorized Transmissive Optoschmitt Sensor Open-Collector Output

ELECTRICAL CHARACTERISTICS (-40°C to +70°C unless otherwise noted)

PARAMETER	SYMBOL	MIN	TYP	MAX	UNITS	TEST CONDITIONS
Operating Supply Voltage	V _{CC}	4.5	5.5		V	T _A =25°C
Supply Current	I _{CC}		40		mA	V _{CC} =5.5 V
Low Level Output Voltage	V _{OL}		0.4		V	V _{CC} =4.5 V, I _{OL} =12.8 mA
High Level Output Current	I _{OH}		100		μA	V _{CC} =5.5 V V _{OH} =28 V
Hysteresis ⁽³⁾	HYST		50		%	
Propagation Delay, Low-High, High-Low	t _{PLH} , t _{PHL}		5		μs	V _{CC} =5 V
Output Rise Time, Output Fall Time	t _r , t _f		70		ns	R _L =8 TTL Loads

Notes

1. It is recommended that a bypass capacitor, 0.1 μF typical, be added between V_{CC} and GND near the device in order to stabilize power supply line.
2. Output is HI when the optical path is interrupted.
3. Hysteresis is defined as the difference between the operating and release threshold intensities, expressed as a percentage of the operate threshold intensity.

ABSOLUTE MAXIMUM RATINGS

(25°C Free-Air Temperature unless otherwise noted)

Operating Temperature Range	-40°C to 70°C
Storage Temperature Range	-40°C to 85°C
Power Dissipation	220 mW
Supply Voltage	5.5 V
Supply Current	40 mA
Low Level Output Current	12.8 mA
Duration of Output Short to V _{CC} or Ground	1.0 sec.
Applied Output Voltage	35 V

HOA7720/7730

Connectorized Transmissive Optoschmitt Sensor

SCHEMATICS FOR HOA7720/7730

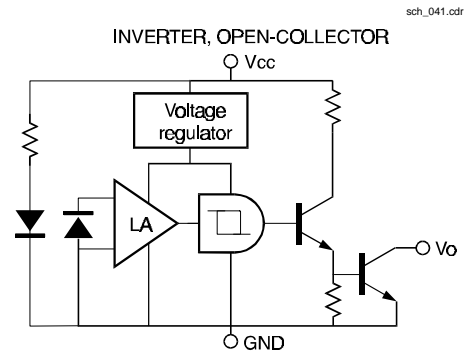
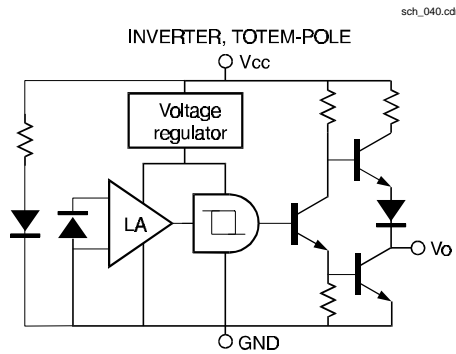

SWITCHING WAVEFORM FOR INVERTERS

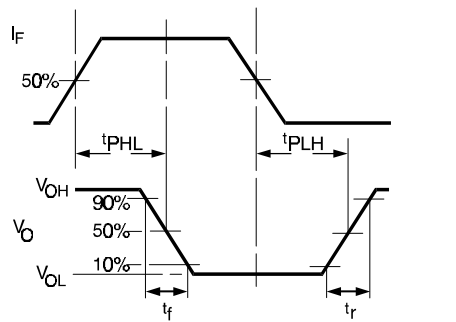

Fig. 1 Output Rise Time (t_r) and Output Fall Time (t_f) vs Temperature

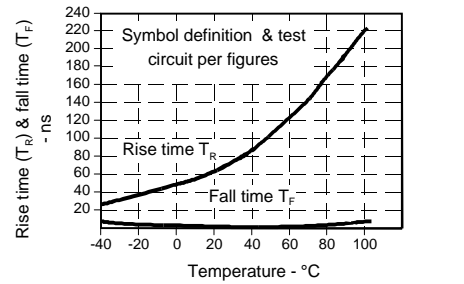
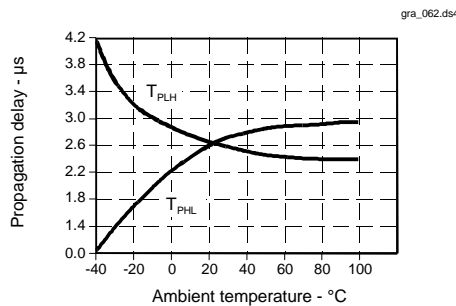

Fig. 2 Delay Time vs Temperature



All Performance Curves Show Typical Values

Honeywell reserves the right to make changes in order to improve design and supply the best products possible.

Honeywell