

THIS DRAWING IS UNPUBLISHED. RELEASED FOR PUBLICATION, 19 .
 © COPYRIGHT 19 BY AMP INCORPORATED. ALL INTERNATIONAL RIGHTS RESERVED.

| LOC | DIST | P | F | ZONE | LTR | DESCRIPTION | DATE | APPD |
|-----|------|---|---|------|-----|---------------------------|-----------|------|
| BD | 50 | | | | C | REDRAWN | 9/27/90 | - |
| | | | | | D | REV PER ECN BD5662 & 5592 | 11/21/91 | - |
| | | | | | E | REV PER EC 0410-251-97 | 22 SEP 97 | JDS |

1. THIS PART TO BE USED WITH:
 PLUG ASSEMBLY 520424-6
 BOTTOM SHIELD 520467-1
 FERRULE 520441-1

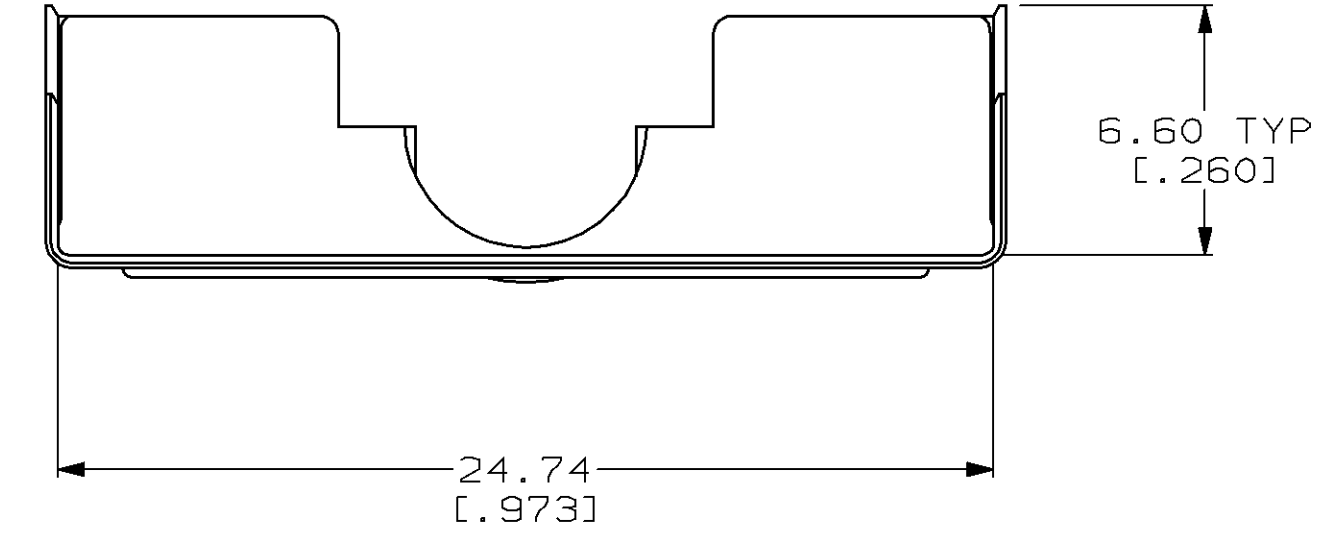
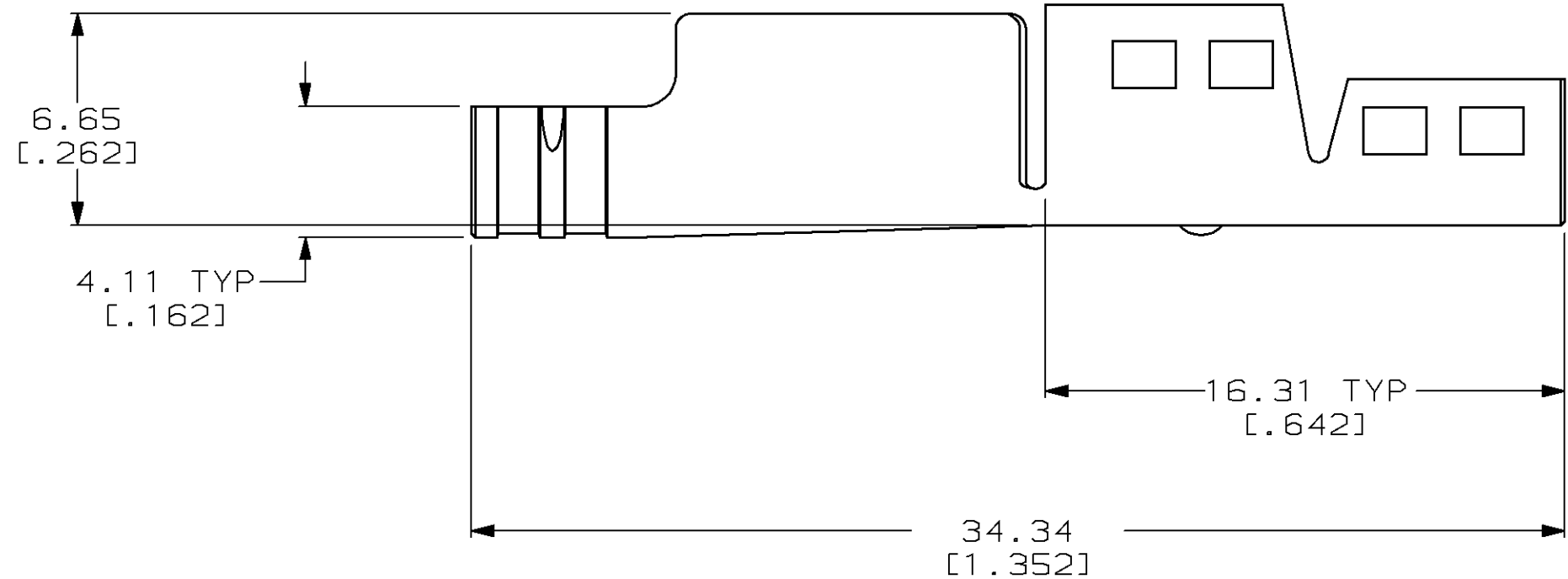

520466-1
 PART NUMBER

| | | | | |
|---|--------------------------------|---|-----------|--|
| DO NOT SCALE PRINT. UNLESS SPECIFIED DIMENSIONS IN mm [INCHES] TOLERANCES ON: 2 PLC DEC ±0.38 [.015] 3 PLC DEC ± - ANGLES ± - | DR 9/27/90 A.STAUB BG | AMP Incorporated Harrisburg, PA 17105-3608 | | |
| | CHK 2-25-91 R.STONE | | | NAME SHELL, TOP HALF, 16 POSITION, SDL |
| MATERIAL 0.320 [.0126] CARBON STEEL | APPD 2-27-91 J.PRITULSKY | SIZE | CAGE CODE | DRAWING NO |
| | APPD - PRODUCT SPEC - | ③ | 00779 | 520466 |
| FINISH 3.81 μm [.000150] MIN TIN OVER 2.54 μm [.000100] MIN COPPER | APPLICATION SPEC - WEIGHT - | SCALE | 5:1 | SHEET 1 OF 1 |