

LOC		DIST		REVISIONS			
DF	DO	REV	PER	DESCRIPTION	DATE	BY	APP'D
		H	REV PER	ECO-05-014837	29DEC05	PY	DM

- THIS RECEPTACLE WILL MATE WITH ANY 13C3, SIZE 3 PLUG IN AMPLIMITE SERIES.
- MAXIMUM WIRE INSULATION TO BE USED WITH THIS RECEPTACLE IS .068 DIA.
- STAINLESS STEEL RETENTION CLIPS (10) ARE INCLUDED IN INSERT ASSEMBLY.
- CONNECTOR SUPPLIED WITH (11) SIGNAL SOCKET CONTACTS; PACKAGED IN A SEPERATE BAG.
- USE 3 SIZE 8 POWER OR COAX SOCKET CONTACTS. CONSULT PRODUCT ENGINEERING FOR MORE DETAILS
- UL/CSA DESIGNATION STAMPED IN THIS AREA, OPTIONAL.
- CADMIUM PER QQ-P-416
- ZINC PLATE PER ASTM-B-633, .000200-.000400 THK WITH SUPPLEMENTARY CHROMATE (Cr3+)

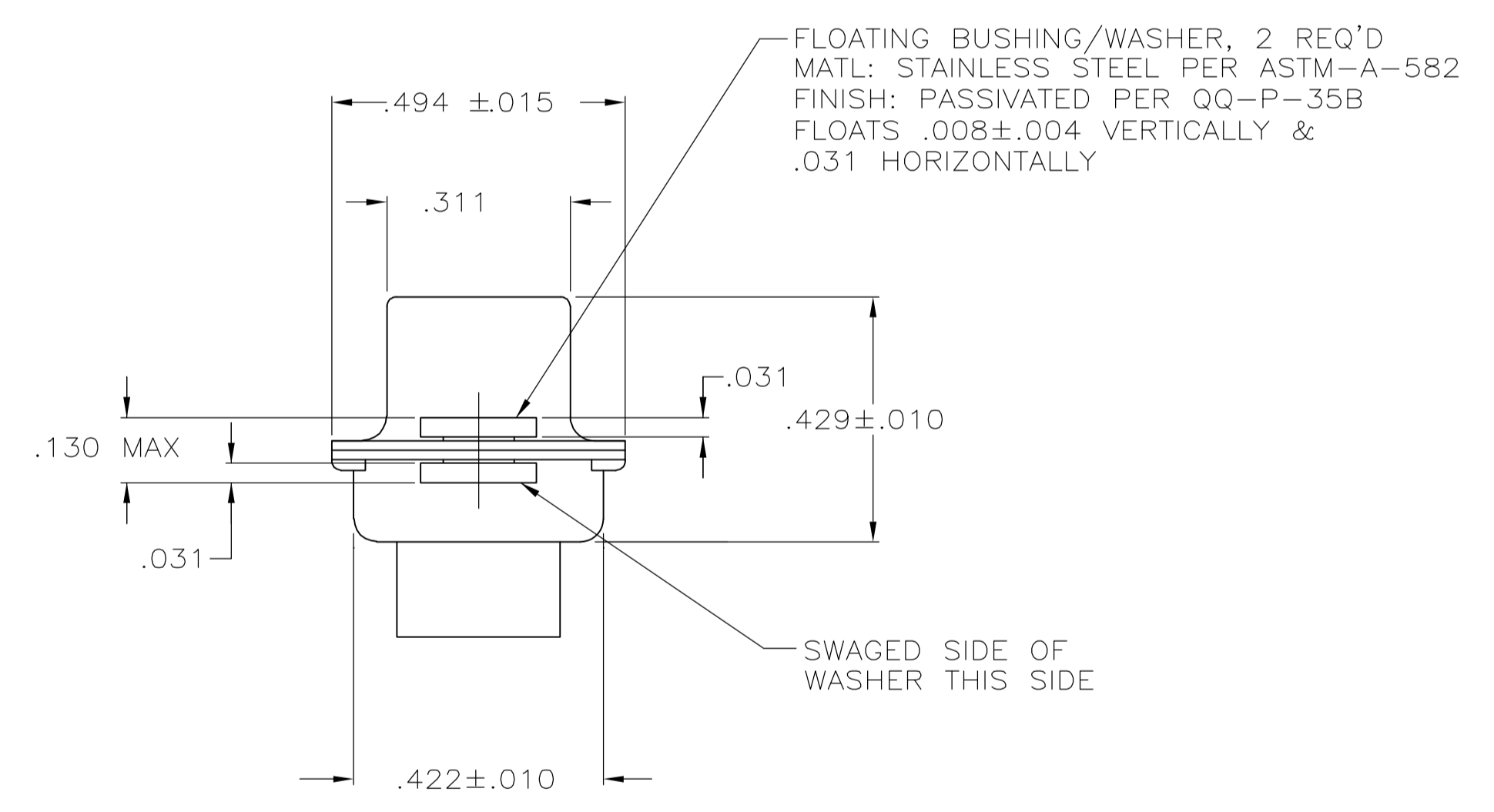
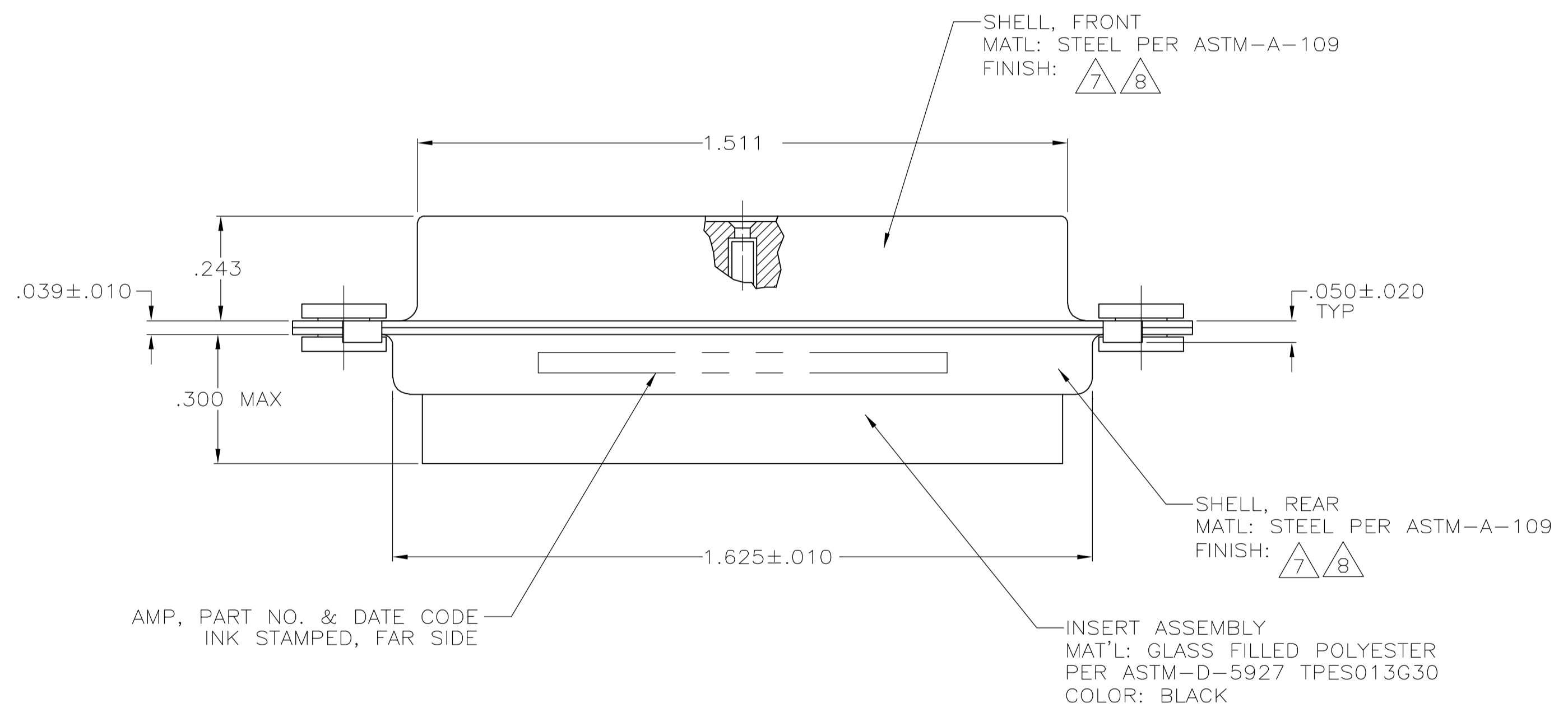
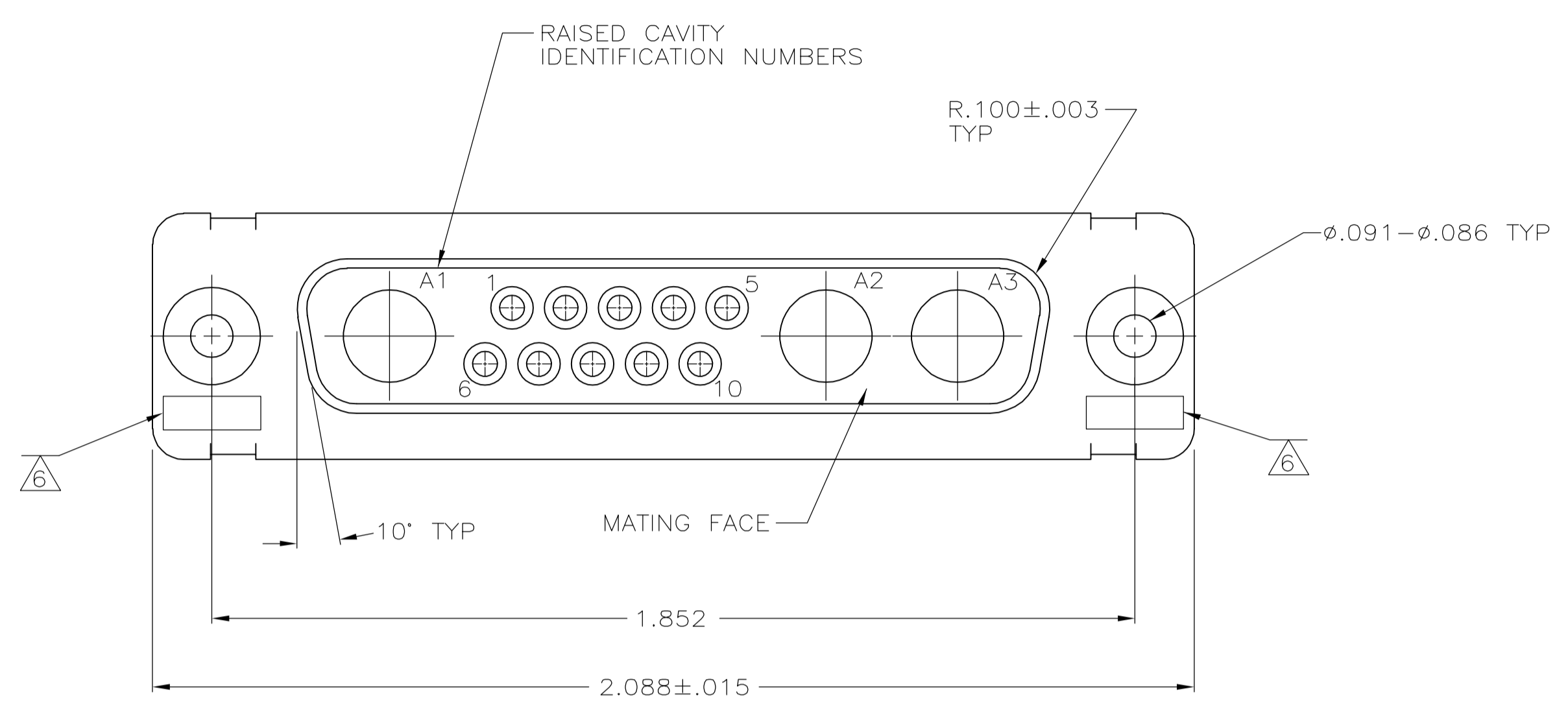

REMARKS	PART NO
8	5-212057-2
7	212057-2
4 7	212057-1

THIS DRAWING IS A CONTROLLED DOCUMENT.

DIMENSIONS: INCHES	TOLERANCES UNLESS OTHERWISE SPECIFIED:	0 PLC ± -	1 PLC ± -	2 PLC ± -	3 PLC ± .005	4 PLC ± -	ANGLES ± 0.30'	FINISH SEE CALLOUTS
--------------------	--	-----------	-----------	-----------	--------------	-----------	----------------	---------------------

APPROVED: A.EMADI	DATE: 03-FEB-88	NAME: RECEPTACLE ASSEMBLY
PRODUCT SPEC: ---	APPLICATION SPEC: ---	SIZE: A1
WEIGHT: ---	CAGE CODE: 00779	DRAWING NO: 212057
CUSTOMER DRAWING	SCALE: 4:1	SHEET: 1 OF 1

tyco Electronics
 Tyco Electronics Corporation
 Harrisburg, Pa 17105-3608