

Servo drive solution for multi-axial position control with Ethernet real-time



Features

- Real-time communication via Ethercat protocol
- Three-phase motor drive inverter based on [STDRIVE101](#) gate driver and [STH270N8F7-2](#) power MOSFET
- [STM32F767ZI](#) microcontroller Arm®32-bit Cortex®-M7
- NETX90 network controller
- Main supply voltage up to 48 V with a max. overvoltage robustness of 60 V
- Max. power dissipation up to 700 W
- Motor brake dissipative energy circuit
- Digital actuation section for industrial loads
- RS485 interface for digital encoder and host interface
- On-board DC-DC converter and linear regulator

Description

The [STEVAL-ETH001V1](#) servo drive evaluation board has been developed to address three-phase PMSM applications oriented to multi-axial position control and connectivity.

The evaluation board embeds a motor control power stage, a digital actuation section and a power management section.

The motor control power stage hosts the [STDRIVE101](#) half-bridge gate driver and six [STH270N8F7-2](#) power MOSFETs, featuring real-time connectivity with Ethercat communication protocol supported by the NETX90 network controller, whereas the digital actuation section hosts an industrial IO management section with [CLT03-2Q3](#) (input) and [IPS160H](#) (output). The power management section is powered by [L7987](#), [L7805CD2T-TR](#) and [LD39150DT33-R](#) devices.

The [STEVAL-ETH001V1](#) is equipped with two RJ45 connectors for daisy chain connection and an [RS485](#) interface for digital encoder or host connection powered by [ST3485EI](#). For a better noise immunity, the PCB is characterized by a 6-layer stack and an insulated track for supply line and ground. A quadrature encoder interface with index is also present.

Product summary	
Servo drive solution for multi-axial position control	STEVAL-ETH001V1
Firmware for servo drive solution enabling motor control position through Ethercat protocol	STSW-ETHDRV01V1
Triple half-bridge gate driver	STDRIVE101
STripFET F7 Power MOSFET	STH270N8F7-2
Arm Cortex-M7 MCU	STM32F767ZI
Applications	3-phase field oriented control Industrial servo drives

1 Schematic diagrams

Figure 1. STEVAL-ETH001V1 circuit schematic (1 of 10)

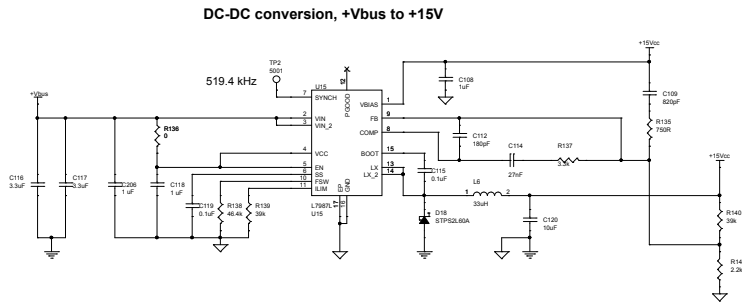
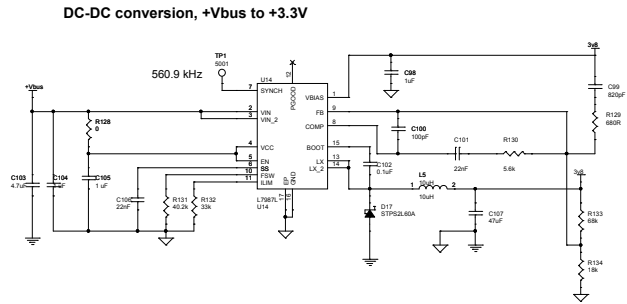
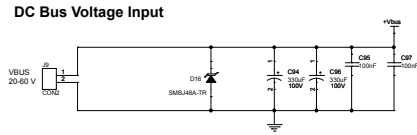

Linear regulation 3.8V to +3.3V

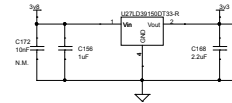

DC-DC conversion, +15Vcc to +5V

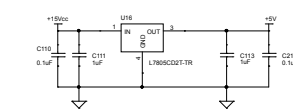

Figure 2. STEVAL-ETH001V1 circuit schematic (2 of 10)

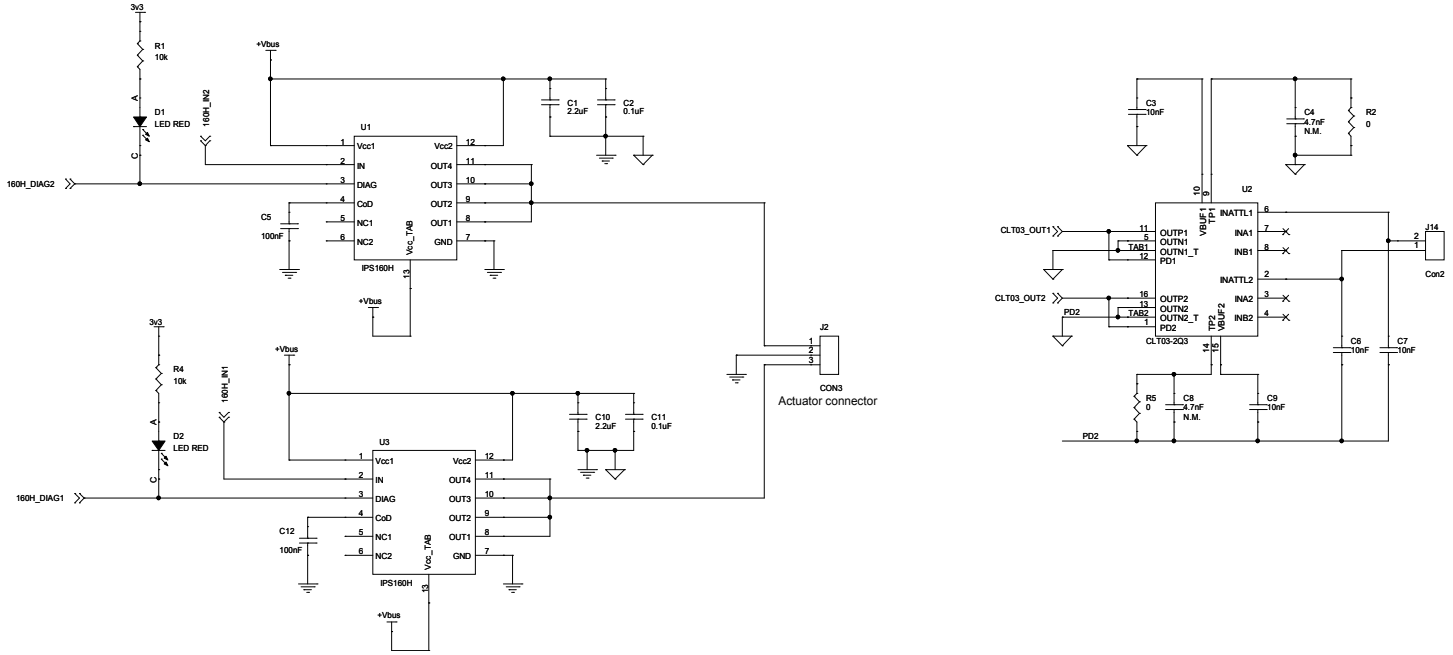

Figure 3. STEVAL-ETH001V1 circuit schematic (3 of 10)

Motion Control - Current Sensing External op-amp

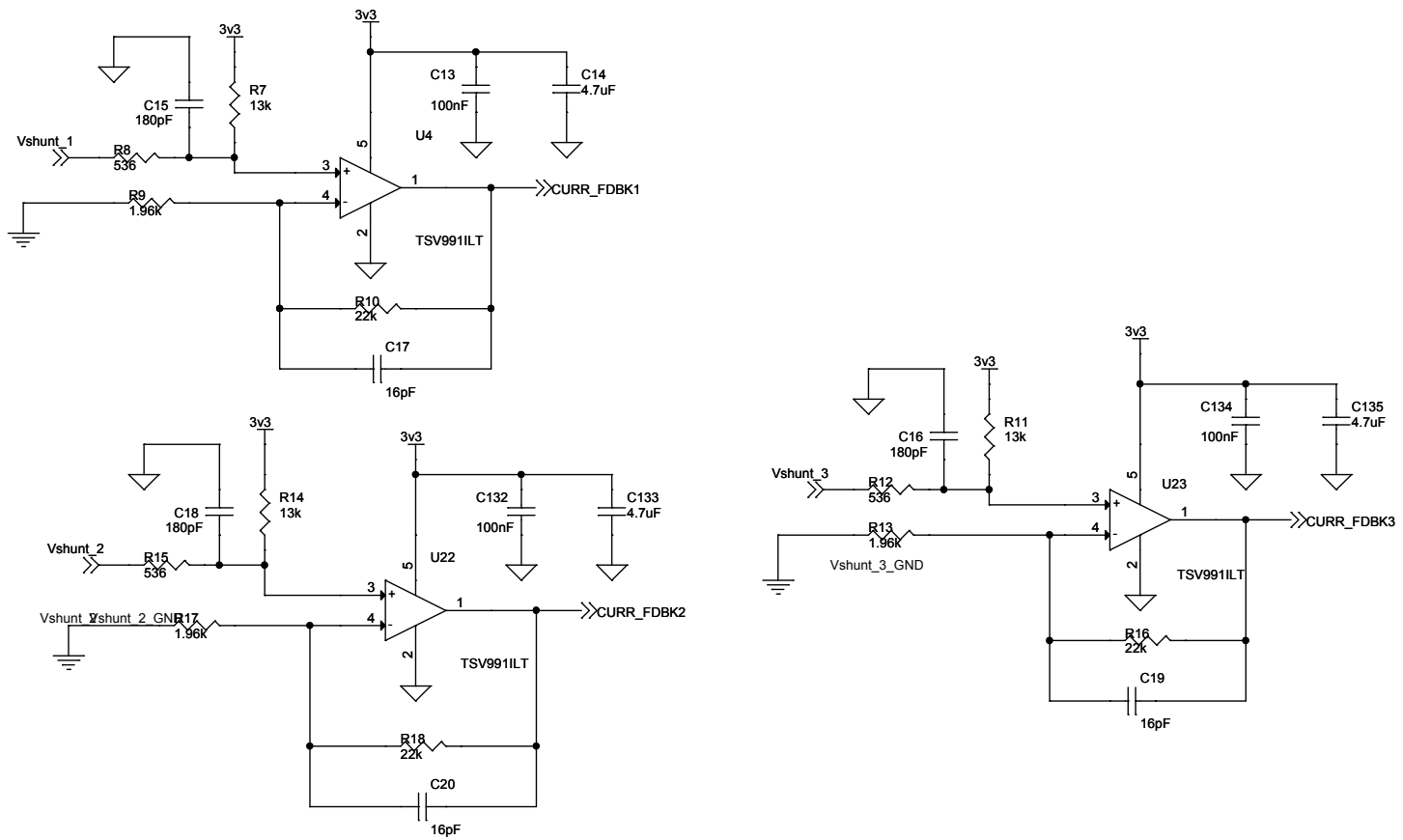

Figure 4. STEVAL-ETH001V1 circuit schematic (4 of 10)

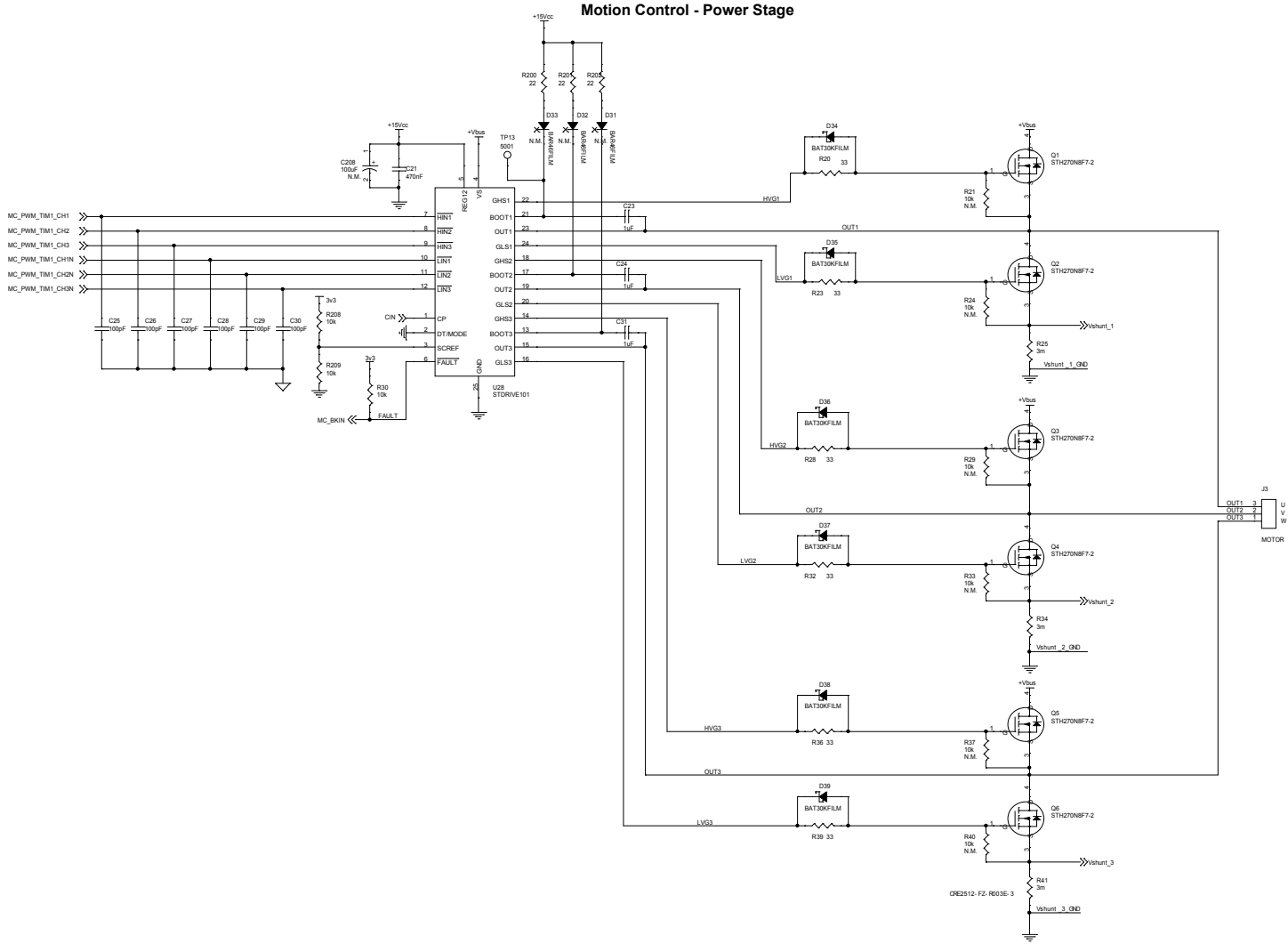
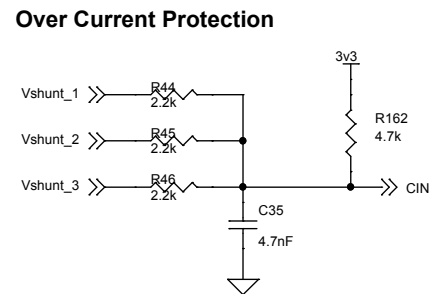
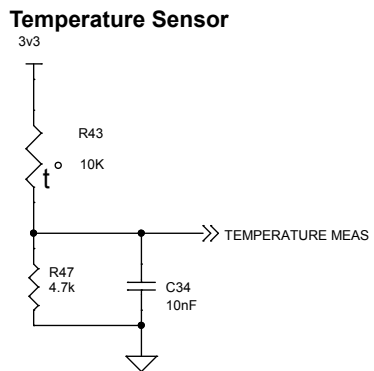
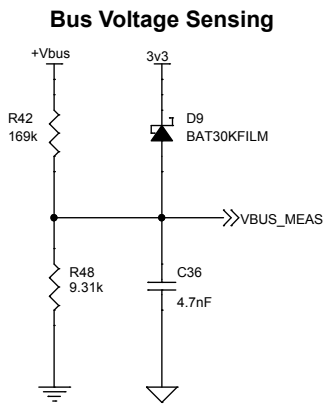

Figure 5. STEVAL-ETH001V1 circuit schematic (5 of 10)



Brake Motor Network for over voltage energy dissipation

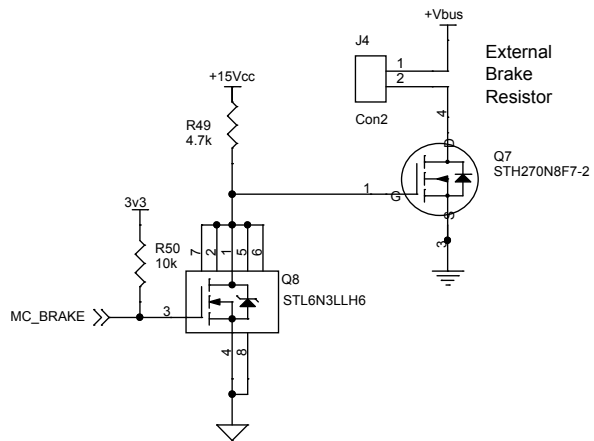

Figure 7. STEVAL-ETH001V1 circuit schematic (7 of 10)

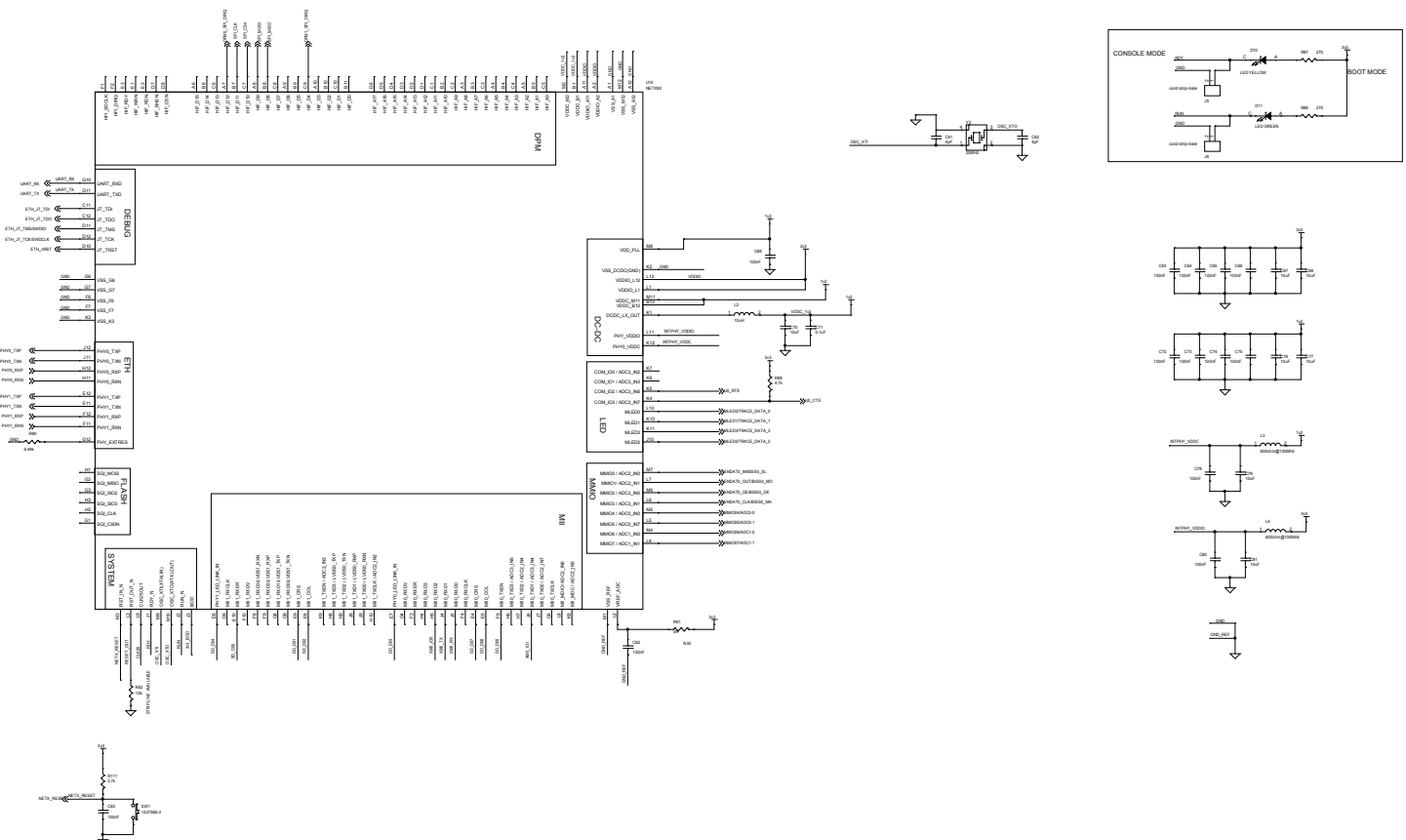

Figure 8. STEVAL-ETH001V1 circuit schematic (8 of 10)

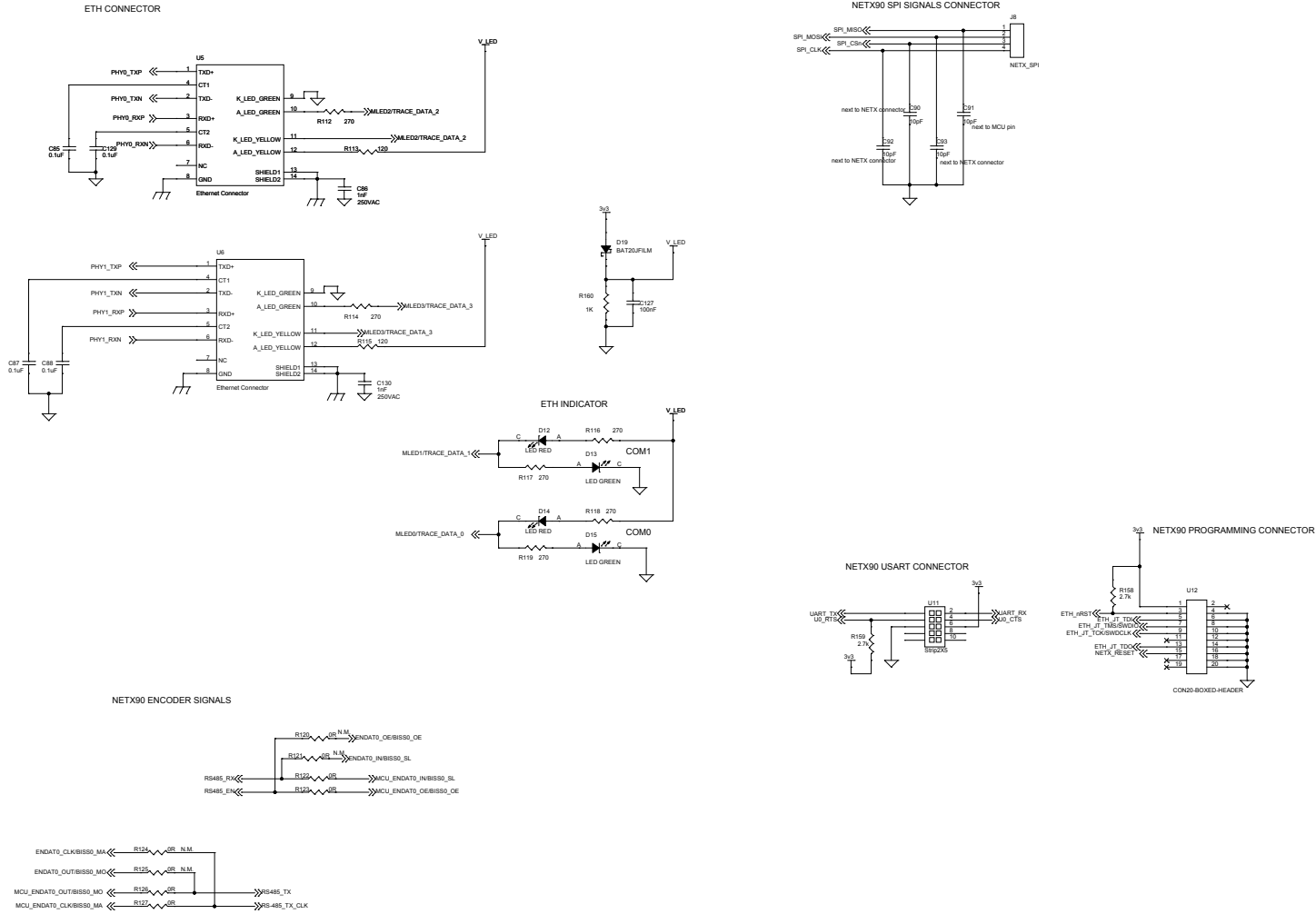

Figure 9. STEVAL-ETH001V1 circuit schematic (9 of 10)

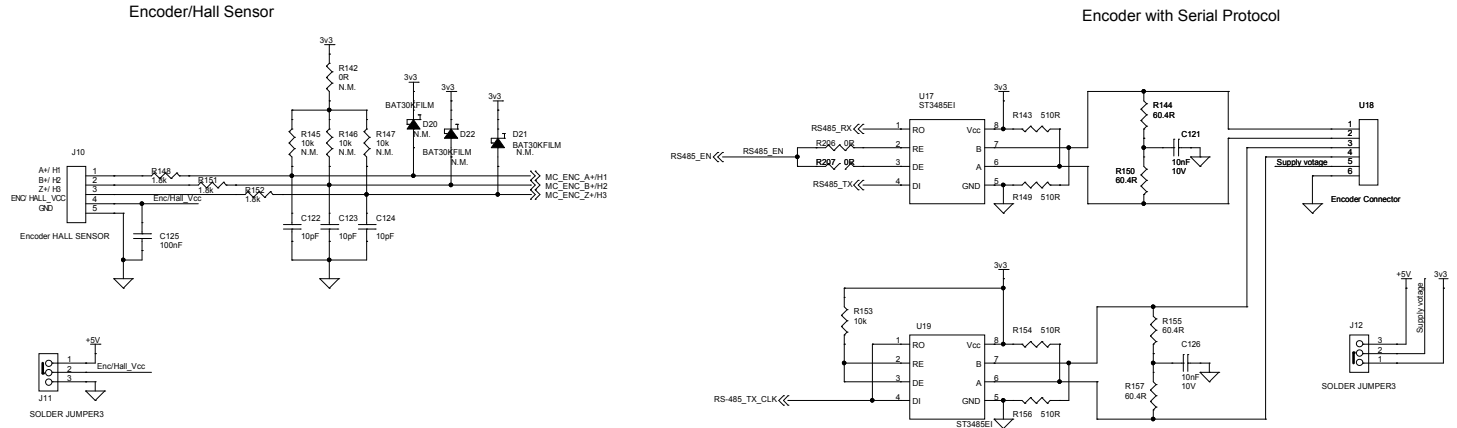
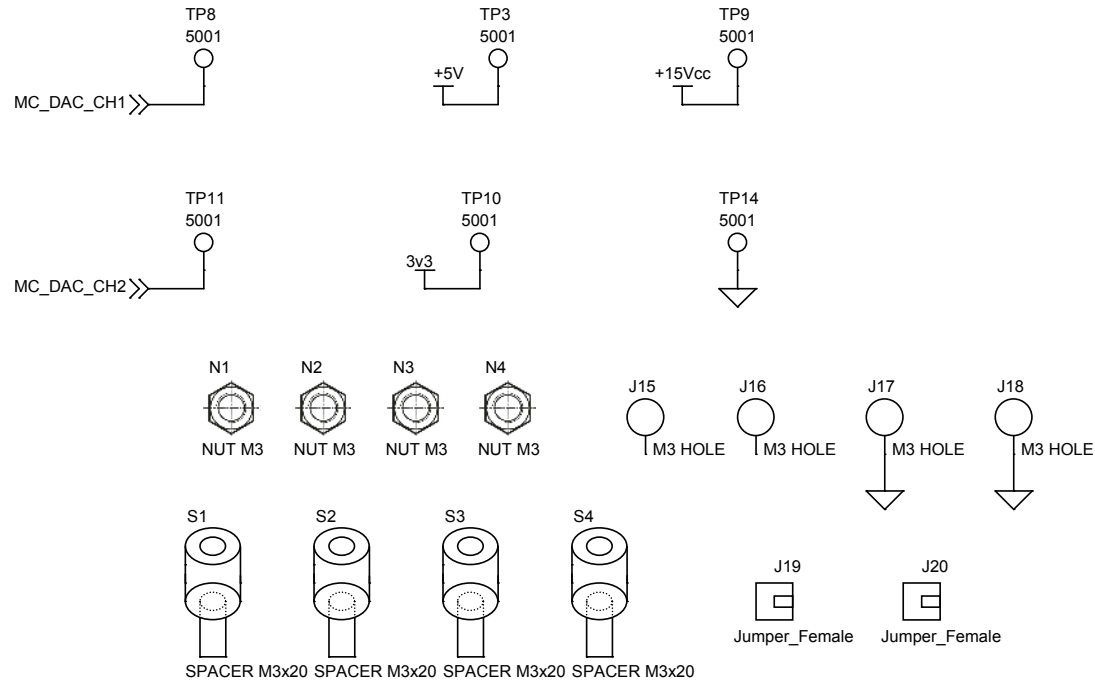

Figure 10. STEVAL-ETH001V1 circuit schematic (10 of 10)

MC DEBUG DAC



Revision history

Table 1. Document revision history

Date	Version	Changes
07-Apr-2021	1	Initial release.

IMPORTANT NOTICE – PLEASE READ CAREFULLY

STMicroelectronics NV and its subsidiaries (“ST”) reserve the right to make changes, corrections, enhancements, modifications, and improvements to ST products and/or to this document at any time without notice. Purchasers should obtain the latest relevant information on ST products before placing orders. ST products are sold pursuant to ST’s terms and conditions of sale in place at the time of order acknowledgement.

Purchasers are solely responsible for the choice, selection, and use of ST products and ST assumes no liability for application assistance or the design of Purchasers’ products.

No license, express or implied, to any intellectual property right is granted by ST herein.

Resale of ST products with provisions different from the information set forth herein shall void any warranty granted by ST for such product.

ST and the ST logo are trademarks of ST. For additional information about ST trademarks, please refer to www.st.com/trademarks. All other product or service names are the property of their respective owners.

Information in this document supersedes and replaces information previously supplied in any prior versions of this document.

© 2021 STMicroelectronics – All rights reserved