

10 9 8 7 6 5 4 3 2 1

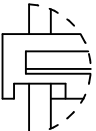

DETAIL Z SCALE 4:1

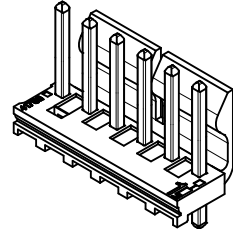
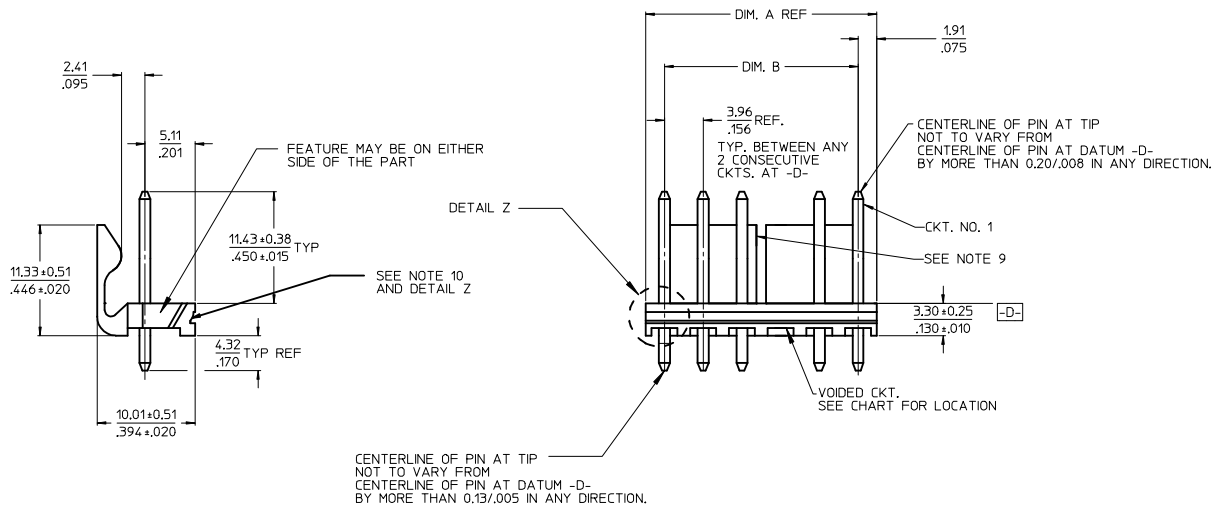
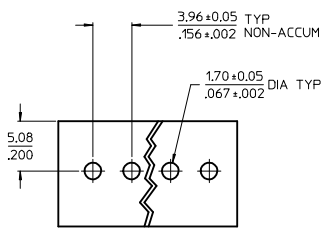

RECOMMENDED P.C. BOARD LAYOUT

- NOTES:
- MATERIAL: HEADER-GLASS FILLED POLYESTER. 94V-0. MOLDED NATURAL (WHITE).
 - FINISH: (222-TIN) OVERALL MATTE TIN: 0.00254/.000100 MIN OVER 0.00127/.000050 MIN NICKEL.
 - PRODUCT SPECIFICATION AND PROCESS PARAMETERS: SEE PS-08-50.
 - PACKAGING INFORMATION: SEE CHARTS.
 - SOLDERABILITY: PER SMES-152.
 - PIN PUSH-OUT FORCE: PRIOR TO SOLDERING, A 3 LB. MINIMUM FORCE (IN EITHER DIRECTION)
 - PARTS ARE STACKABLE END TO END ON 3.96/.156 CENTERS.
 - THIS PART CONFORMS TO CLASS B REQUIREMENTS OF COSMETIC SPECIFICATION PS-45499-002.
 - SLOTS ON BACKWALL ARE BETWEEN CIRCUITS. SEE CHART FOR LOCATION.
 - FEATURE MAY OR MAY NOT EXTEND ACROSS THE ENTIRE FACE OF THE PART *SEE DETAIL Z*.

CKT	DIM. A	DIM. B	SLOT LOC BETWEEN CKTS
2	7.77 .306	3.96±0.05 .156±.002	NONE
3	11.73 .462	7.92±0.08 .312±.003	NONE
4	15.70 .618	11.89±0.08 .468±.003	NONE
5	19.66 .774	15.85±0.10 .624±.004	NONE
6	23.62 .930	19.81±0.10 .780±.004	3 & 4
7	27.58 1.086	23.77±0.10 .936±.004	4 & 5
8	31.55 1.242	27.74±0.13 1.092±.005	4 & 5
9	35.51 1.398	31.70±0.13 1.248±.005	5 & 6
10	39.47 1.554	35.66±0.13 1.404±.005	5 & 6
11	43.43 1.710	39.62±0.15 1.560±.006	6 & 7
12	47.40 1.866	43.59±0.15 1.716±.006	4 & 5 8 & 9
13	51.36 2.022	47.55±0.15 1.872±.006	4 & 5 9 & 10
14	55.32 2.178	51.51±0.18 2.028±.007	5 & 6 9 & 10
15	59.28 2.334	55.47±0.18 2.184±.007	5 & 6 10 & 11
16	63.25 2.490	59.44±0.18 2.340±.007	5 & 6 11 & 12
17	67.21 2.646	63.40±0.20 2.496±.008	6 & 7 11 & 12
18	71.17 2.802	67.36±0.20 2.652±.008	6 & 7 12 & 13

NO. OF CIRCUITS	PART NUMBER	VOIDED CIRCUIT
2	367720002	
3	367720003	
4	367720004	
5	367720005	
6	367720006	
7	367720007	
8	367720008	
9	367720009	
10	367720010	
11	367720011	
12	367720012	
13	367720013	
14	367720014	
3	367720001	2

CORRECT DIMENSIONS EC NO: UCP2014-0504 DRWN:HKIPPER 2013/08/02 CHKD:JBELL 2013/08/02 APPR:FSMITH 2013/08/06	QUALITY SYMBOLS ▽=0 ▽=0 ▽=0	GENERAL TOLERANCES (UNLESS SPECIFIED) mm INCH 4 PLACES ± --- ±.0002 3 PLACES ± 0.005 ±.005 2 PLACES ± 0.13 ±.01 1 PLACE ± 0.25 ± --- 0 PLACE ± ±	DIMENSION STYLE IN/MM DRAWN BY DATE SNS01 2010/05/12 CHECKED BY DATE SAMIEC 98/10/09 APPROVED BY DATE KPRASAD 2010/06/22	SCALE 2:1 DESIGN UNITS INCH THIRD ANGLE PROJECTION	TITLE KK 156 HEADER ASSEMBLY FRICTION LOCK VERTICAL SOLID BODY W/O PEGS molex DOCUMENT NO. SD-36772-001 SHEET NO. 1 OF 1
		ANGULAR ±1/2° DRAFT WHERE APPLICABLE MUST REMAIN WITHIN DIMENSIONS	MATERIAL NO. SEE CHART		
		THIS DRAWING CONTAINS INFORMATION THAT IS PROPRIETARY TO MOLEX INCORPORATED AND SHOULD NOT BE USED WITHOUT WRITTEN PERMISSION			

9 8 7 6 5 4 3 2 1

10 9 8 7 6 5 4 3 2 1

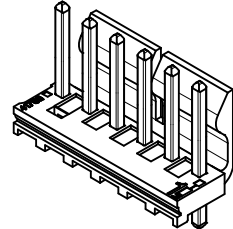
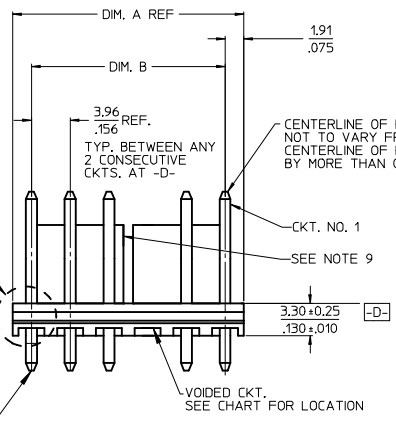
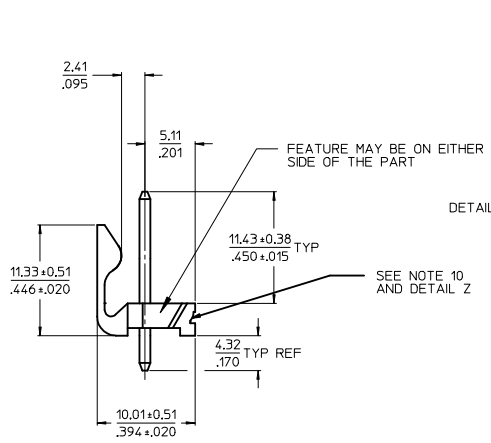

CENTERLINE OF PIN AT TIP NOT TO VARY FROM CENTERLINE OF PIN AT DATUM -D- BY MORE THAN 0.13/.005 IN ANY DIRECTION.

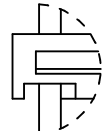

DETAIL Z SCALE 4:1

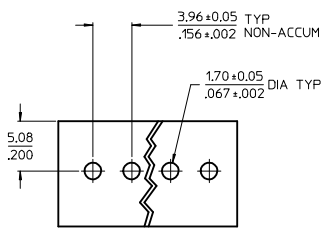

RECOMMENDED P.C. BOARD LAYOUT

- NOTES:
- MATERIAL: HEADER-GLASS FILLED POLYESTER. 94V-0. MOLDED NATURAL (WHITE).
 - FINISH: (222-TIN) OVERALL MATTE TIN: 0.00254/.000100 MIN OVER 0.00127/.000050 MIN NICKEL.
 - PRODUCT SPECIFICATION AND PROCESS PARAMETERS: SEE PS-08-50.
 - PACKAGING INFORMATION: SEE CHARTS.
 - SOLDERABILITY: PER SMES-152.
 - PIN PUSH-OUT FORCE: PRIOR TO SOLDERING, A 3 LB. MINIMUM FORCE (IN EITHER DIRECTION)
 - PARTS ARE STACKABLE END TO END ON 3.96/.156 CENTERS.
 - THIS PART CONFORMS TO CLASS B REQUIREMENTS OF COSMETIC SPECIFICATION PS-45499-002.
 - SLOTS ON BACKWALL ARE BETWEEN CIRCUITS. SEE CHART FOR LOCATION.
 - FEATURE MAY OR MAY NOT EXTEND ACROSS THE ENTIRE FACE OF THE PART *SEE DETAIL Z*.

CKT	DIM. A	DIM. B	SLOT LOC BETWEEN CKTS
2	7.77 .306	3.96±0.05 .156±0.002	NONE
3	11.73 .462	7.92±0.08 .312±0.003	NONE
4	15.70 .618	11.89±0.08 .468±0.003	NONE
5	19.66 .774	15.85±0.10 .624±0.004	NONE
6	23.62 .930	19.81±0.10 .780±0.004	3 & 4
7	27.58 1.086	23.77±0.10 .936±0.004	4 & 5
8	31.55 1.242	27.74±0.13 1.092±0.005	4 & 5
9	35.51 1.398	31.70±0.13 1.248±0.005	5 & 6
10	39.47 1.554	35.66±0.13 1.404±0.005	5 & 6
11	43.43 1.710	39.62±0.15 1.560±0.006	6 & 7
12	47.40 1.866	43.59±0.15 1.716±0.006	4 & 5 8 & 9
13	51.36 2.022	47.55±0.15 1.872±0.006	4 & 5 9 & 10
14	55.32 2.178	51.51±0.18 2.028±0.007	5 & 6 9 & 10
15	59.28 2.334	55.47±0.18 2.184±0.007	5 & 6 10 & 11
16	63.25 2.490	59.44±0.18 2.340±0.007	5 & 6 11 & 12
17	67.21 2.646	63.40±0.20 2.496±0.008	6 & 7 11 & 12
18	71.17 2.802	67.36±0.20 2.652±0.008	6 & 7 12 & 13

NO. OF CIRCUITS	PART NUMBER	VOIDED CIRCUIT
2	367720002	
3	367720003	
4	367720004	
5	367720005	
6	367720006	
7	367720007	
8	367720008	
9	367720009	
10	367720010	
11	367720011	
12	367720012	
13	367720013	
14	367720014	
3	367720001	2

CORRECT DIMENSIONS EC NO: UCP2014-0504 DRWN:HKIPPER 2013/08/02 CHKD:JBELL 2013/08/02 APPR:FSMITH 2013/08/06	QUALITY SYMBOLS ▽=0 ▽=0 ▽=0	GENERAL TOLERANCES (UNLESS SPECIFIED) mm INCH 4 PLACES ± --- ± .0002 3 PLACES ± 0.005 ± .005 2 PLACES ± 0.13 ± .01 1 PLACE ± 0.25 ± --- 0 PLACE ± ±	DIMENSION STYLE IN/MM DRAWN BY DATE SNS01 2010/05/12 CHECKED BY DATE SAMIEC 98/10/09 APPROVED BY DATE KPRASAD 2010/06/22	SCALE 2:1 DESIGN UNITS INCH THIRD ANGLE PROJECTION	TITLE KK 156 HEADER ASSEMBLY FRICTION LOCK VERTICAL SOLID BODY W/O PEGS molex	MATERIAL NO. SEE CHART DOCUMENT NO. SD-36772-001 SHEET NO. 1 OF 1
		ANGULAR ± 1/2° DRAFT WHERE APPLICABLE MUST REMAIN WITHIN DIMENSIONS	THIS DRAWING CONTAINS INFORMATION THAT IS PROPRIETARY TO MOLEX INCORPORATED AND SHOULD NOT BE USED WITHOUT WRITTEN PERMISSION			

9 8 7 6 5 4 3 2 1