

High Accuracy Analog Speed Sensor IC with Integrated Filter Capacitor and Dual Zero-Crossing Output Signal

FEATURES AND BENEFITS

- Used in sensing motion of ring magnet or ferrous targets
- Integrated filter capacitor
- Wide operating temperature range
- Operation with magnetic input signal frequency from 20 Hz to 20 kHz
- Resistant to EMI
- Large effective air gaps
- 4.0 to 26.5 V supply operating range
- Output compatible with both TTL and CMOS logic families
- Reverse battery protection
- Resistant to mechanical and thermal stress
- Accurate true zero-crossing switch point

PACKAGE: 4 pin SIP (suffix K)

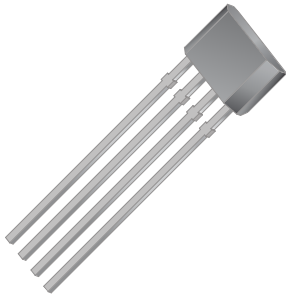

DESCRIPTION

The A1425 AC-coupled Hall-effect sensor IC is a monolithic integrated circuit that switches in response to changing differential magnetic fields created by rotating ring magnets and, when coupled with a magnet, by ferrous targets. The device is a true zero-crossing detector: the output switches precisely when the difference in magnetic field strength between the two Hall elements is zero. A unique dual-comparator scheme provides for accurate switching at the zero crossing on both the positive and negative-going regions of the differential signal, while utilizing hysteresis to prevent false switching. The zero-crossing nature of this device provides excellent repeatability and accuracy for crankshaft applications.

Changes in field strength at the device face, which are induced by a moving target, are sensed by the two integrated Hall transducers. The transducers generate signals that are differentially amplified by on-chip electronics. This differential design provides immunity to radial vibration within the operating air gap range of the A1425, by rejection of the common mode signal. Steady-state magnet and system offsets are eliminated using an on-chip differential band-pass filter. This filter also provides relative immunity to interference from electromagnetic sources.

Continued on the next page...

Functional Block Diagram

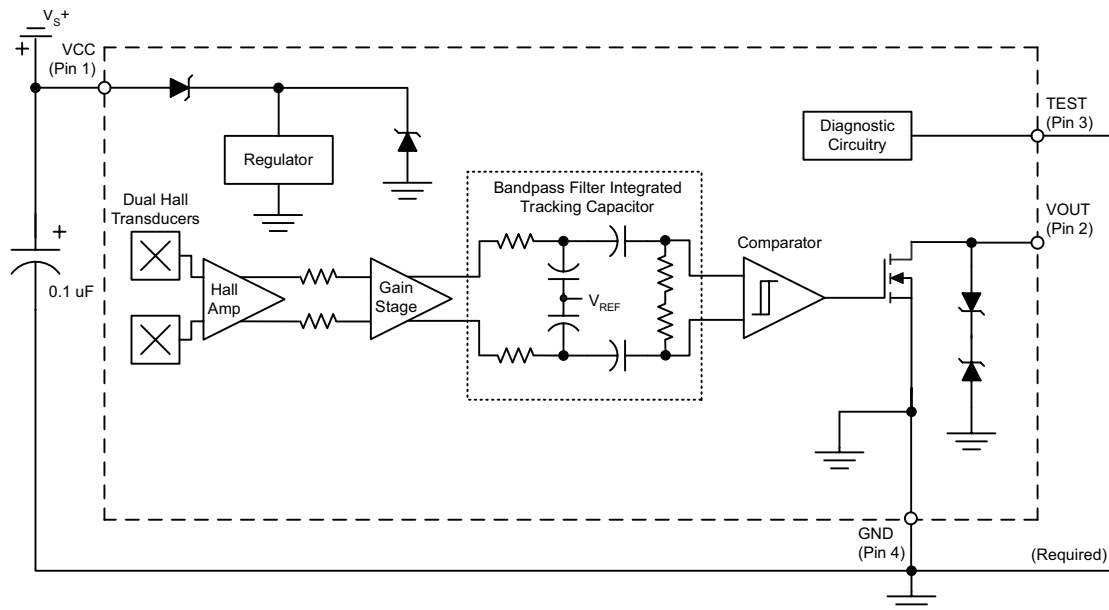

DESCRIPTION (continued)

The device uses advanced temperature compensation for the high-pass filter, sensitivity, and Schmitt trigger switch points, to guarantee optimal operation to low frequencies over a wide range of air gaps and temperatures.

Each Hall effect digital integrated circuit includes a voltage regulator, two Hall effect elements, temperature compensating circuitry, a low-level amplifier, band-pass filter, Schmitt trigger,

and an output driver, which requires a pull-up resistor. The on-board regulator permits operation with supply voltages from 4.0 to 26.5 V. The output stage can easily switch 20 mA over the full frequency response range of the device, and is compatible with both TTL and CMOS logic circuits.

The device is packaged in a 4-pin plastic SIP. It is lead (Pb) free, with 100% matte tin plated leadframe.

SELECTION GUIDE

Part Number	Packing*	Switch Points	
		B _{RP(MIN)} (G)	B _{OP(MAX)} (G)
A1425LK-T	Bulk, 500 pieces/bag	-11	11



*Contact Allegro for additional packing options.

ABSOLUTE MAXIMUM RATINGS

Characteristic	Symbol	Notes	Rating	Units
Supply Voltage	V _{CC}	Refer to Power Derating section	28	V
Reverse Supply Voltage	V _{RCC}		-18	V
Continuous Output Current	I _{OUT}		25	mA
Continuous Reverse-Output Current	I _{ROUT}		-50	mA
Operating Ambient Temperature	T _A	Range L	-40 to 150	°C
Maximum Junction	T _{J(max)}		165	°C
Storage Temperature	T _{stg}		-65 to 170	°C

Pinout Diagram

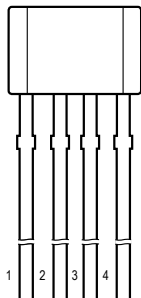

Terminal List Table

Name	Number
VCC	1
VOUT	2
TEST	3
GND	4

OPERATING CHARACTERISTICS Valid at $T_A = -40^\circ\text{C}$ to 150°C , $T_J \leq 165^\circ\text{C}$; over operational air gap range and V_{CC} within operating range, unless otherwise noted. Typical operating parameters: $V_{CC} = 12\text{ V}$ and $T_A = 25^\circ\text{C}$.

Characteristic	Symbol	Test Conditions	Min.	Typ.	Max.	Units
ELECTRICAL CHARACTERISTICS						
Supply Voltage	V_{CC}	Operating; $T_J < T_{J(max)}$	4.0	–	26.5	V
Supply Current	I_{CC}		–	4.2	7.0	mA
Output Saturation Voltage	$V_{OUT(SAT)}$	$I_{SINK} = 20\text{ mA}$	–	140	400	mV
Output Leakage Current	I_{OFF}	$V_{OUT} = 24\text{ V}$, $B_{diff} = 0$	–	–	5	μA
PROTECTION COMPONENT CHARACTERISTICS						
Reverse Supply Current	I_{RCC}	$V_{CC} = -18\text{ V}$	–	–	-1	mA
Supply Zener Current	$I_{ZSupply}$	$V_S = 28\text{ V}$	–	–	10	mA
Supply Zener Clamp Voltage [1]	$V_{ZSupply}$	$I_{CC} = 10\text{ mA}$, $T_A = 25^\circ\text{C}$	28	33	37	V
Output Zener Current	$I_{ZOutput}$	$V_{OUT} = 28\text{ V}$	–	–	3	mA
Output Zener Clamp Voltage	$V_{ZOutput}$	$I_{OUT} = 3\text{ mA}$, $T_A = 25^\circ\text{C}$	28	–	–	V
Output Short Circuit Current Limit [2]	$I_{OUTS(lim)}$		–	–	50	mA
RESPONSE CHARACTERISTICS						
Power-On State	POS	$t < t_{Response}$	–	High	–	V
Power-On Time [3][7]	t_{PO}	$V_{CC} > V_{CC(min)}$	–	4.5	9	ms
Settling Time [4][7]	t_{Settle}	$f_{Bdiff} \geq 100\text{ Hz}$	0	–	50	ms
Response Time [7]	$t_{Response}$	Equal to $t_{PO} + t_S$; $f_{Bdiff} \geq 100\text{ Hz}$	4.5	–	59	ms
Upper Corner Frequency	f_{cu}	-3 dB, single pole	20	–	–	kHz
Lower Corner Frequency	f_{cl}	-3 dB, single pole	–	–	20	Hz
OUTPUT CHARACTERISTICS						
Output Rise Time [5]	t_r	$R_{PU} = 1\text{ k}\Omega$, $C_{OUT2} = 10\text{ pF}$	–	–	200	ns
Output Fall Time	t_f	$R_{PU} = 1\text{ k}\Omega$, $I_{SINK} = 20\text{ mA}$, $C_{OUT2} = 10\text{ pF}$	–	–	200	ns
MAGNETIC CHARACTERISTICS						
Output Off Switch Point [6][7]	B_{OP}	B_{diff} increasing, $f_{Bdiff} = 200\text{ Hz}$, $B_{diff} = 50\text{ Gp-p}$; digital output signal switches low to high	-11	0	11	G
Output On Switch Point [6][7]	B_{RP}	B_{diff} decreasing, $f_{Bdiff} = 200\text{ Hz}$, $B_{diff} = 50\text{ Gp-p}$; digital output signal switches high to low	-11	0	11	G
Applied Magnetic Field [7][8]	B_{diff}	Differential p-p magnetic field	50	–	1250	G

[1] I_{CC} equivalent to $I_{CC(max)} + 3\text{ mA}$.

[2] I_{OUT} does not change state when $I_{OUT} > I_{OUTS(lim)}$, regardless of changes in the impinging magnetic field.

[3] Time required to initialize device.

[4] Time required for the output switch points to be within specification.

[5] Output Rise Time will be dominated by the RC time constant.

[6] For other sinusoidal signal frequencies and magnetic fields, $-B_{OP} = B_{RP} = \sin(\alpha) \cdot B_{diff}/2 \pm 25\%$, where α is the phase shift shown in the Characteristic Data section.

[7] See Definitions of Terms section.

[8] Exceeding the maximum magnetic field may result in compromised absolute accuracy.

THERMAL CHARACTERISTICS may require derating at maximum conditions; see application information

Characteristic	Symbol	Test Conditions	Rating	Units
Package Thermal Resistance	$R_{\theta JA}$	Single-layer PCB, with copper limited to solder pads	177	$^{\circ}\text{C}/\text{W}$

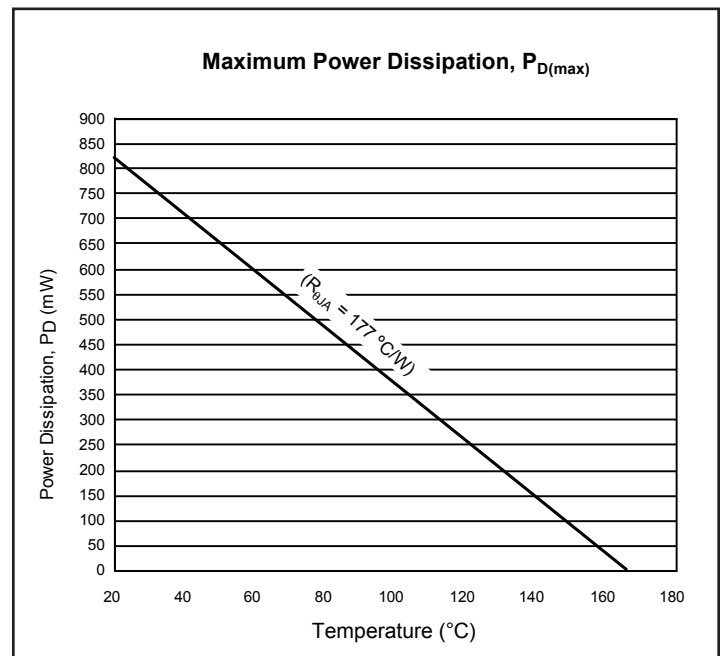
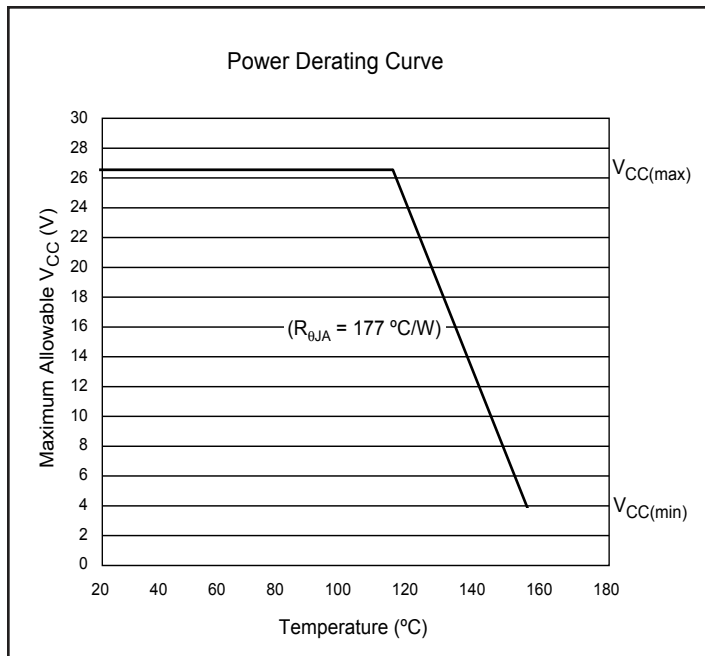

Definitions of Terms

The following provide additional information about some of the parameters cited in the Operating Characteristics table. For additional information, visit the Allegro Web site at www.allegromicro.com.

Applied Magnetic Field, B_{diff} – The differential magnetic flux density which is calculated as the arithmetic difference of the flux densities observed by each of the two Hall elements.

Output Off Switch Point (Operate Point), B_{OP} – The value of increasing differential magnetic flux density at which the device output switches from low to high. This value may be greater than or less than 0 G.

Output On Switch Point (Release Point), B_{RP} – The value of decreasing differential magnetic flux density at which the device

output switches from high to low. This value may be greater than or less than 0 G.

Power-On Time, t_{PO} – The time needed by the device, after power is applied, to initialize all circuitry necessary for proper operation.

Settling Time, t_{Settle} – The time required by the device, after t_{PO} and after a valid magnetic signal has been applied, to provide proper output transitions. Settling time is a function of magnetic offset, offset polarity, signal phase, signal frequency, and signal amplitude.

Response Time t_{Response} – The total time required for generating zero-crossing output transitions after power-up (the sum of power-on time and settling time).

EMPIRICAL RESULTS

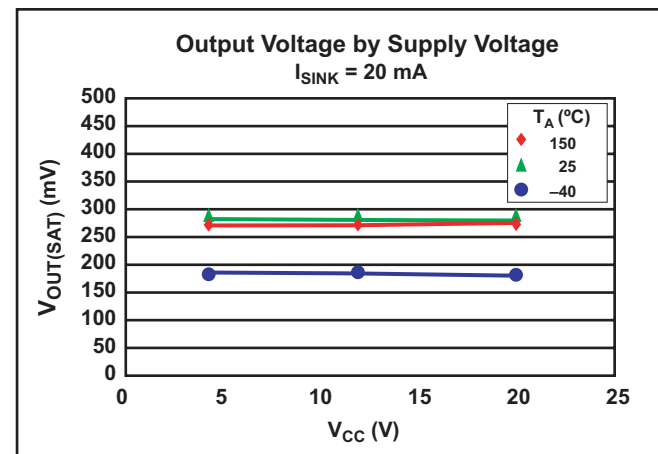
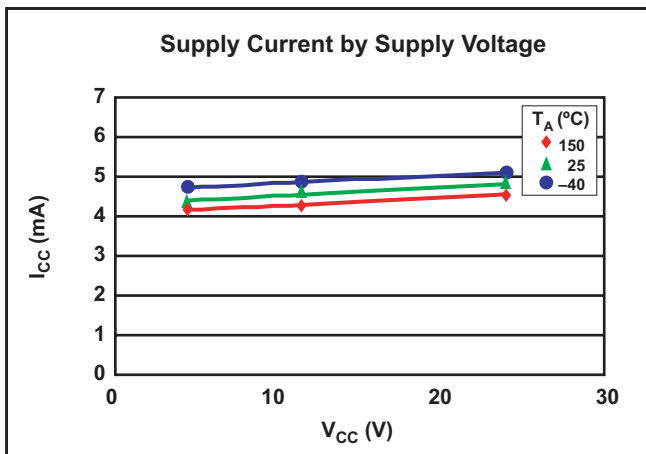
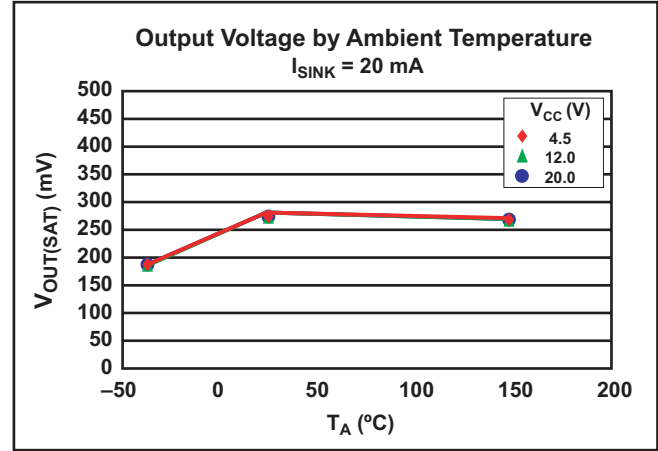
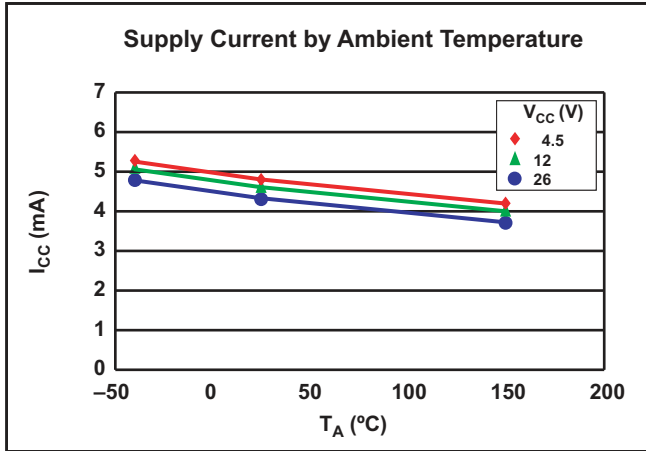

Continued on next page.

EMPIRICAL RESULTS, continued

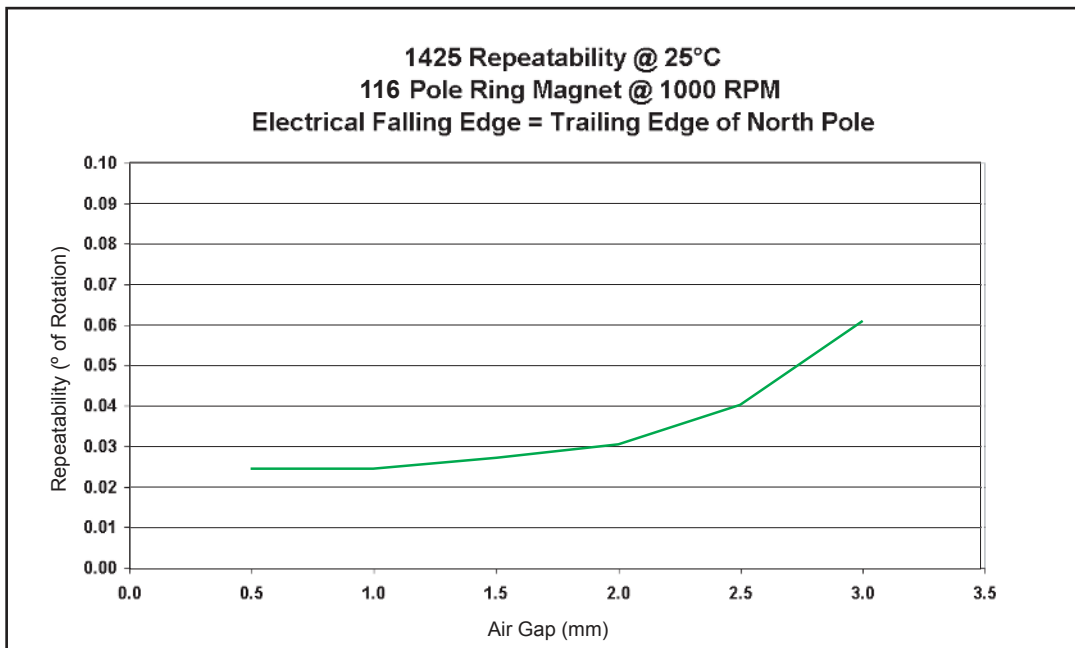
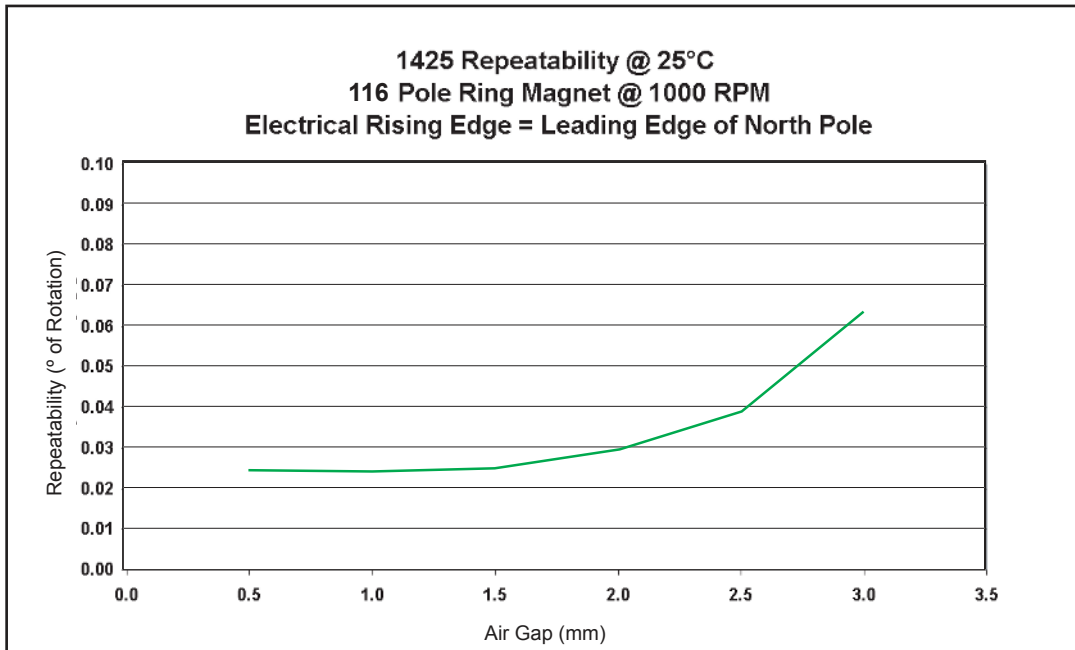

SIMULATION RESULTS

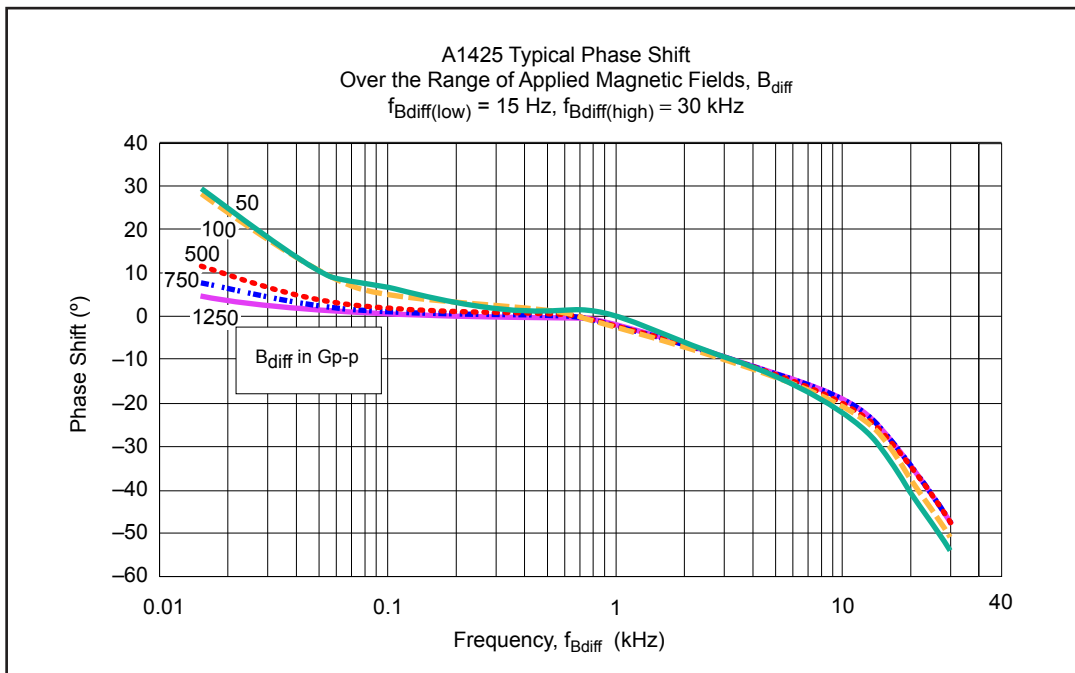
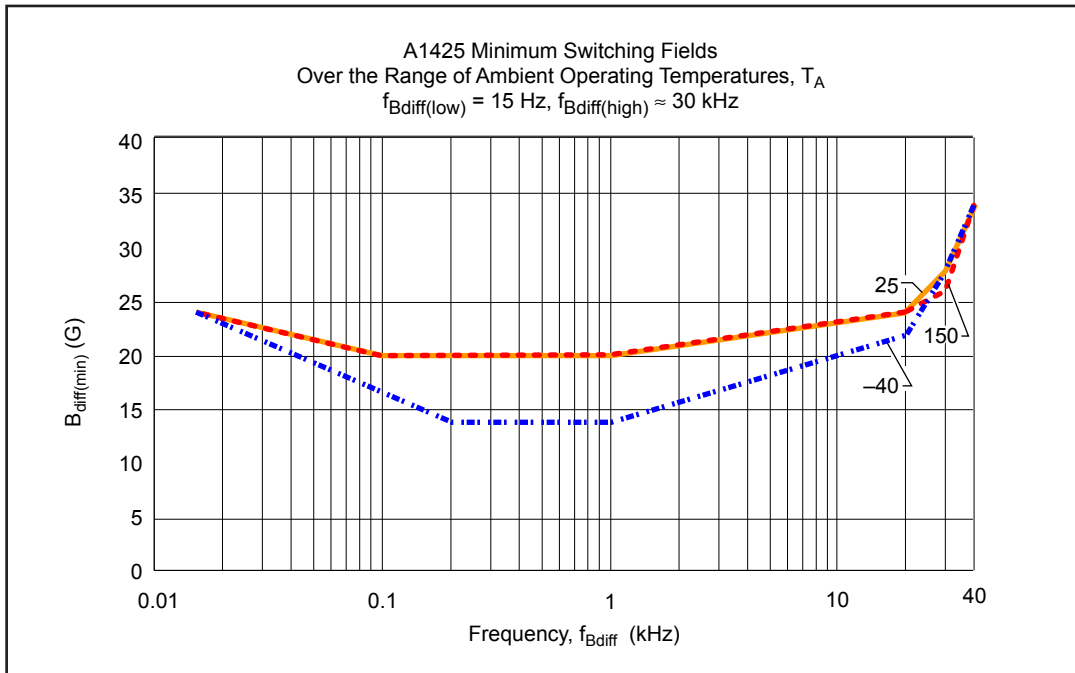

Continued on next page.

SIMULATION RESULTS, continued

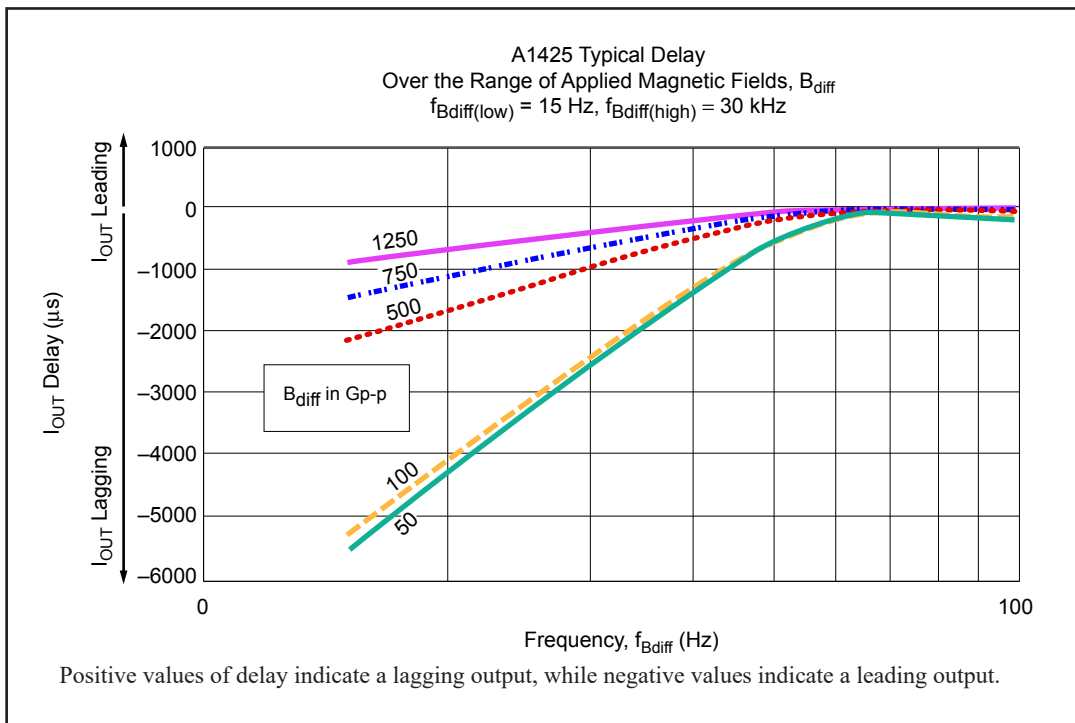
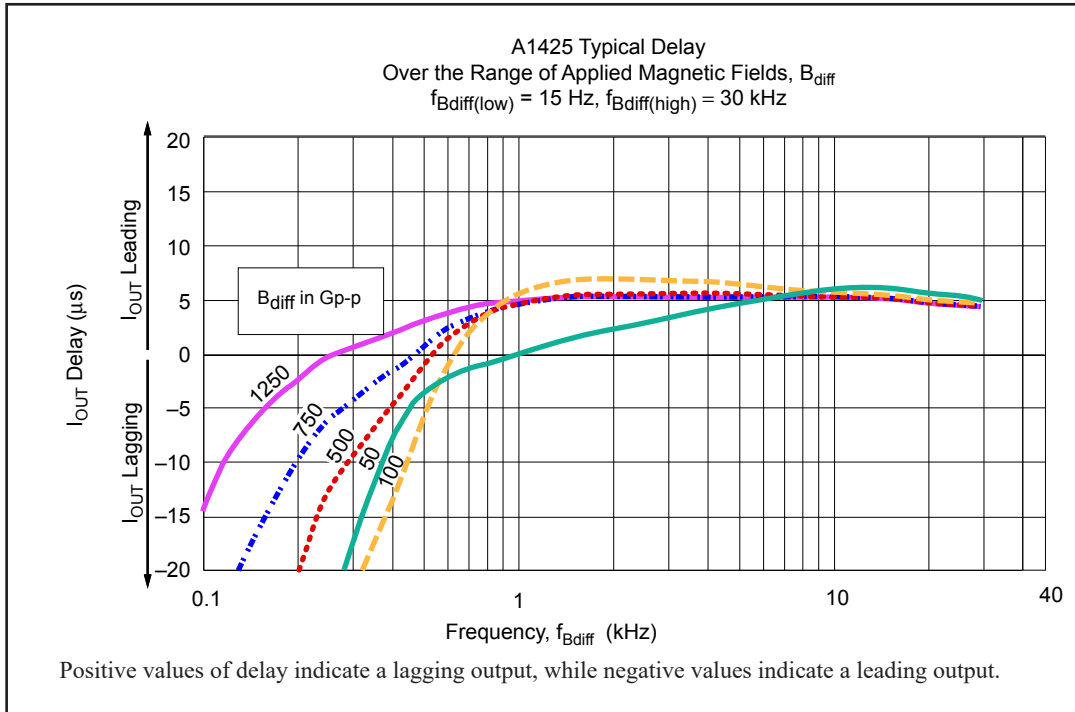

DEVICE EVALUATION: EMC CHARACTERIZATION

Contact Allegro MicroSystems for EMC performance information.

Test Name	Reference Specification
ESD – Human Body Model*	AEC-Q100-002
ESD – Machine Model*	AEC-Q100-003
Conducted Transients	ISO 7637-1
Direct RF Injection	ISO 11452-7
Bulk Current Injection	ISO 11452-4
TEM Cell	ISO 11452-3

*ESD testing is performed with no external components.

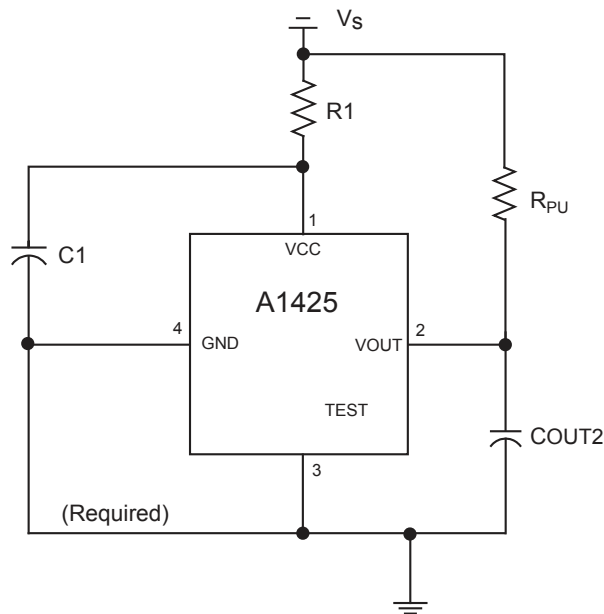

Recommended EMC test circuit.

Component	Value	Units
R_{PU} [a]	1.2	$k\Omega$
R1 [b]	100	Ω
C1	0.1	μF
C_{OUT} [c]	4.7	nF

[a] Pull-up resistor not required for protection but for normal operation.

[b] For improved CI performance.

[c] For improved BCI performance.

FUNCTIONAL DESCRIPTION

The A1425 is a versatile high-precision differential Hall-effect device that can be used in a wide range of applications. Proper choice of the target material and shape, and assembly techniques enables large working air gaps and high switch point accuracy over the device operating temperature range.

Device Operation

The A1425 sensor IC contains two integrated Hall transducers that are used to differentially respond to a magnetic field across the surface of the IC. Referring to figure 1, the trigger switches the output off (output high) when the differential magnetic field crosses zero while increasing in strength (referred to as the positive direction), and switches the output on (output low) when the differential magnetic field crosses zero while decreasing (the negative direction).

The operation is achieved through the use of two separate comparators. Both comparators use the same reference point, 0 G, to provide high accuracy, but one comparator has a positive hysteresis, B_{HYS1} , and the other a negative hysteresis, B_{HYS2} . Therefore, one comparator switches (B_{OP}) at the zero crossing on an increasing differential signal and the other switches (B_{RP}) at the zero crossing on a decreasing differential signal. The hysteresis on each comparator precludes false switching on noise or target jitter.

Start-Up

During power-on time, t_{PO} , the output signal, V_{OUT} , is high. Beyond this time, if the applied magnetic field, B_{diff} , is absent or less than 50 G peak-to-peak, the switching state and V_{OUT} polarity are indeterminate. V_{OUT} will be valid for $B_{diff} > 50$ Gp-p, after the additional settling time, t_{Settle} , has also elapsed. Also during t_{PO} , a circuit in the A1425 is briefly enabled that charges the on-chip capacitor. This feature reduces t_{PO} , relative to the long RC time constant of a high-pass filter.

Delay

The on-chip band-pass filter induces delay in the output signal, V_{OUT} , relative to the applied magnetic field, B_{diff} . Simulation data shown in the Characteristic Data section quantify the effect of the input signal amplitude on the phase shift of the output.

AC-Coupled Operation

Steady-state magnet and system offsets are eliminated using an on-chip differential band-pass filter. The low and high frequency poles of this band-pass filter are set using internal integrated capacitors and resistors. The differential structure of this filter improves the ability of the IC to reject single-ended noise on the ground (GND pin) or supply line (VCC pin) and, as a result, makes it more resistant to electromagnetic interference typically seen in hostile remote-sensing environments.

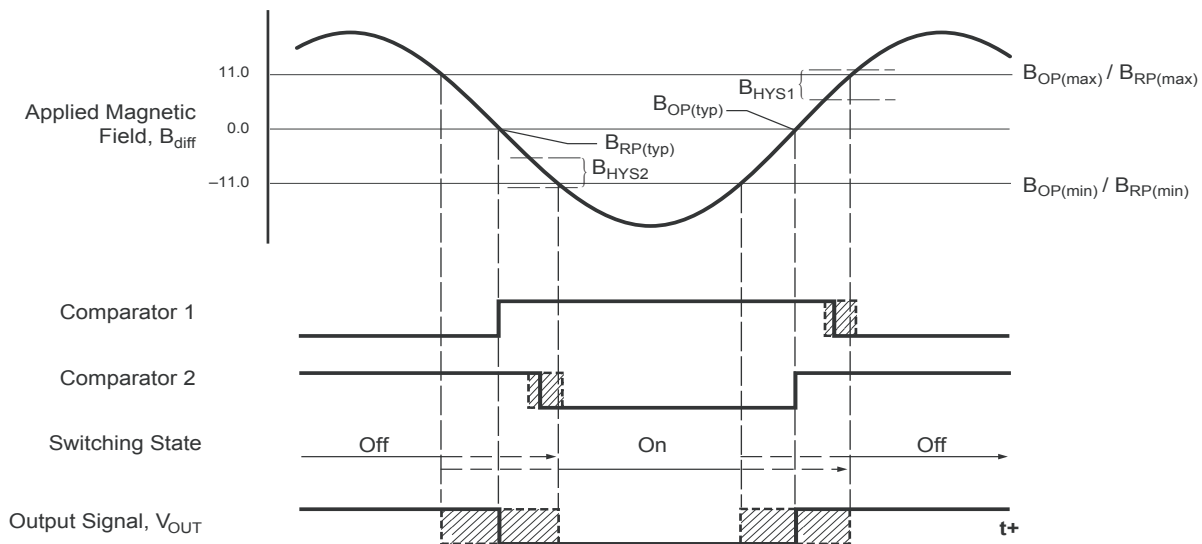

Figure 1. Typical output characteristics with dual comparator operation. Characteristics shown without delay, see Characteristic Data section charts for delay and phase shift contributions.

APPLICATIONS INFORMATION

Target Selection

The zero-crossing switch points and AC-coupled operation of this device make target selection important. For high-density target geometries or small target features that produce a sinusoidal magnetic signal, the high-pass filter is capable of filtering offsets that may be induced in the final device output. If such offset is present, and the target has larger features, then the high-pass filter may not be effective at higher speeds and an accuracy shift may occur. These relationships are shown in figure 2.

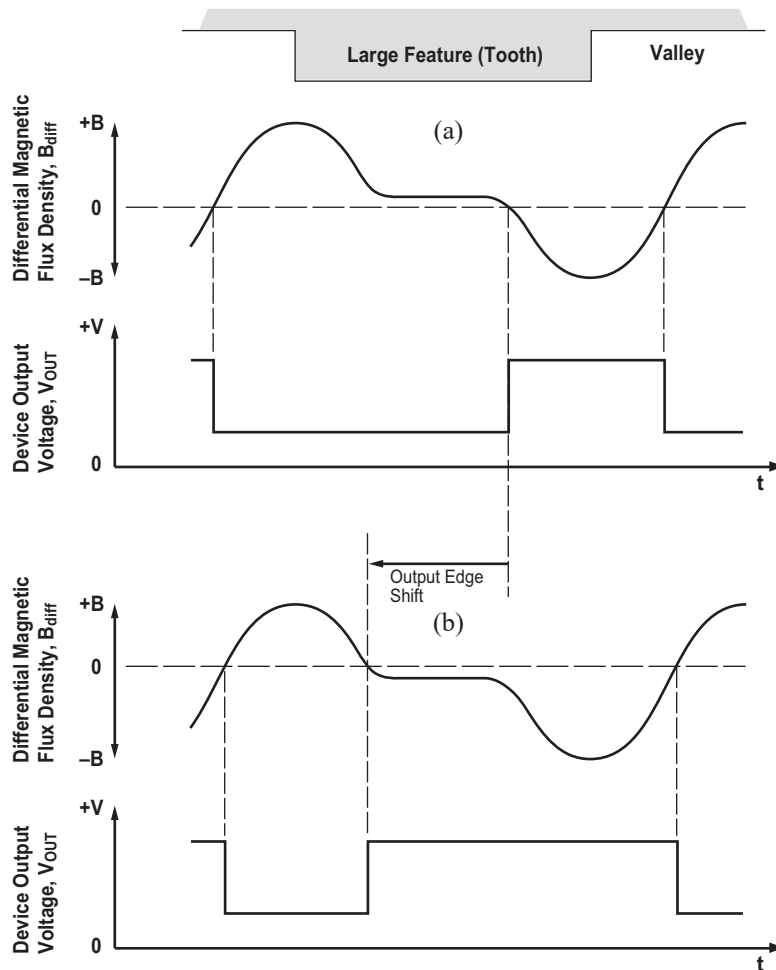

Figure 2. Large Feature Effects. (a) Large target feature but no device offset, normal edge position. (b) Large target feature with negative device offset, shifted (advanced) output edge position.

Power Supply Protection

The A1425 contains an on-chip voltage regulator and can operate over a wide supply voltage range. In applications that operate the device from an unregulated power supply, transient protection must be added externally. For applications using a regulated line, EMI/RFI protection may still be required. The circuit shown in figure 3 is the most basic configuration required for proper device operation.

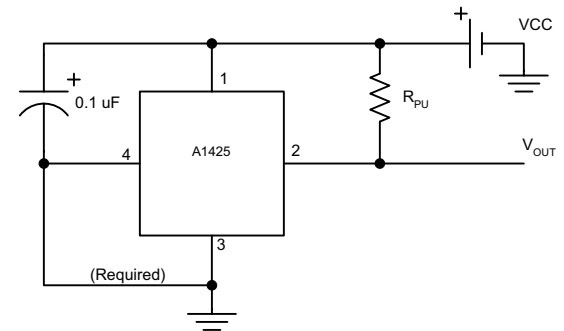

Figure 3. Basic application circuit. A pull-up resistor, R_{PU} , is required with the output driver.

Power Derating

The device must be operated below the maximum junction temperature of the device, $T_J(\text{max})$. Under certain combinations of peak conditions, reliable operation may require derating supplied power or improving the heat dissipation properties of the application. This section presents a procedure for correlating factors affecting operating T_J . (Thermal data is also available on the Allegro MicroSystems Web site.)

The Package Thermal Resistance, $R_{\theta JA}$, is a figure of merit summarizing the ability of the application and the device to dissipate heat from the junction (die), through all paths to the ambient air. Its primary component is the Effective Thermal Conductivity, K , of the printed circuit board, including adjacent devices and traces. Radiation from the die through the device case, $R_{\theta JC}$, is relatively small component of $R_{\theta JA}$. Ambient air temperature, T_A , and air motion are significant external factors, damped by overmolding.

The effect of varying power levels (Power Dissipation, P_D), can be estimated. The following formulas represent the fundamental relationships used to estimate T_J , at P_D .

$$P_D = V_{IN} \times I_{IN} \quad (1)$$

$$\Delta T = P_D \times R_{\theta JA} \quad (2)$$

$$T_J = T_A + \Delta T \quad (3)$$

For example, given common conditions such as: $T_A = 25^\circ\text{C}$, $V_{CC} = 5.0\text{ V}$, $I_{CC} = 4.2\text{ mA}$, and $R_{\theta JA} = 177\text{ }^\circ\text{C/W}$, then:

$$P_D = V_{CC} \times I_{CC} = 5.0\text{ V} \times 4.2\text{ mA} = 21.0\text{ mW}$$

$$\Delta T = P_D \times R_{\theta JA} = 21.0\text{ mW} \times 177\text{ }^\circ\text{C/W} = 3.7^\circ\text{C}$$

$$T_J = T_A + \Delta T = 25^\circ\text{C} + 3.7^\circ\text{C} = 28.7^\circ\text{C}$$

A worst-case estimate, $P_D(\text{max})$, represents the maximum allowable power level ($V_{CC}(\text{max})$, $I_{CC}(\text{max})$), without exceeding $T_J(\text{max})$, at a selected $R_{\theta JA}$ and T_A .

Example

Reliability for V_{CC} at $T_A = 150^\circ\text{C}$, using minimum-K PCB

Observe the worst-case ratings for the device, specifically: $R_{\theta JA} = 177^\circ\text{C/W}$, $T_J(\text{max}) = 165^\circ\text{C}$, $V_{CC}(\text{max}) = 26.5\text{ V}$, and $I_{CC}(\text{max}) = 7.0\text{ mA}$.

Calculate the maximum allowable power level, $P_D(\text{max})$. First, invert equation 3:

$$\Delta T_{\text{max}} = T_J(\text{max}) - T_A = 165^\circ\text{C} - 150^\circ\text{C} = 15^\circ\text{C}$$

This provides the allowable increase to T_J resulting from internal power dissipation. Then, invert equation 2:

$$P_D(\text{max}) = \Delta T_{\text{max}} \div R_{\theta JA} = 15^\circ\text{C} \div 177\text{ }^\circ\text{C/W} = 84\text{ mW}$$

Finally, invert equation 1 with respect to voltage:

$$V_{CC(\text{est})} = P_D(\text{max}) \div I_{CC}(\text{max}) = 84\text{ mW} \div 7.0\text{ mA} = 12\text{ V}$$

The result indicates that, at T_A , the application and device can dissipate adequate amounts of heat at voltages $\leq V_{CC(\text{est})}$.

Compare $V_{CC(\text{est})}$ to $V_{CC}(\text{max})$. If $V_{CC(\text{est})} \leq V_{CC}(\text{max})$, then reliable operation between $V_{CC(\text{est})}$ and $V_{CC}(\text{max})$ requires enhanced $R_{\theta JA}$. If $V_{CC(\text{est})} \geq V_{CC}(\text{max})$, then operation between $V_{CC(\text{est})}$ and $V_{CC}(\text{max})$ is reliable under these conditions.

For example, when a standard diode with a 0.7 V drop is used: $V_S(\text{max}) = 12\text{ V} + 0.7\text{ V} = 12.7\text{ V}$

PACKAGE K, 4-PIN SIP

For Reference Only - Not for Tooling Use

(Reference DWG-0000395)

Dimensions in millimeters - NOT TO SCALE

Dimensions exclusive of mold flash, gate burs, and dambar protrusions
Exact case and lead configuration at supplier discretion within limits shown

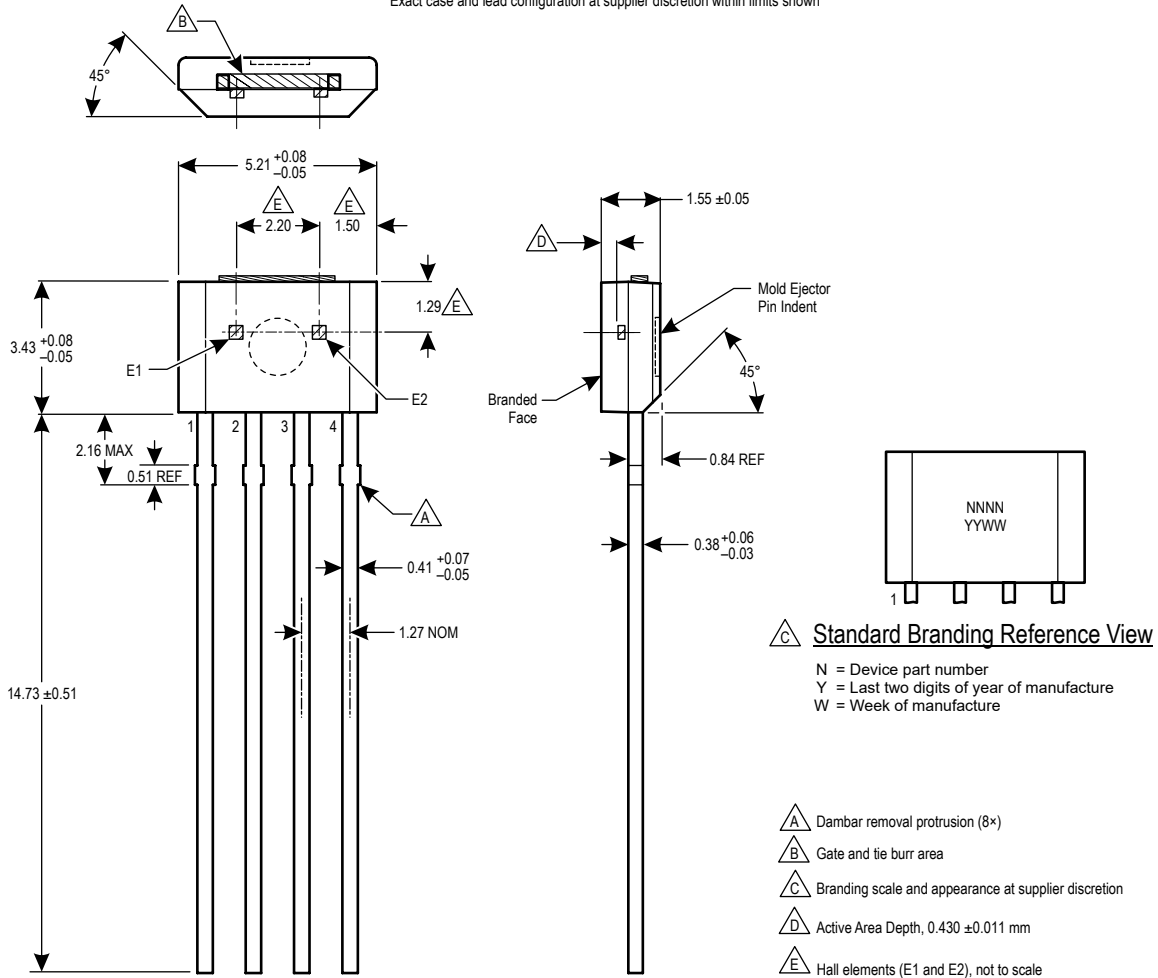

Revision History

Number	Date	Description
4	February 22, 2019	Minor editorial updates
5	February 27, 2020	Minor editorial updates
6	February 21, 2022	Updated package drawings (page 13)

Copyright 2022, Allegro MicroSystems.

Allegro MicroSystems reserves the right to make, from time to time, such departures from the detail specifications as may be required to permit improvements in the performance, reliability, or manufacturability of its products. Before placing an order, the user is cautioned to verify that the information being relied upon is current.

Allegro's products are not to be used in any devices or systems, including but not limited to life support devices or systems, in which a failure of Allegro's product can reasonably be expected to cause bodily harm.

The information included herein is believed to be accurate and reliable. However, Allegro MicroSystems assumes no responsibility for its use; nor for any infringement of patents or other rights of third parties which may result from its use.

Copies of this document are considered uncontrolled documents.

For the latest version of this document, visit our website:

www.allegromicro.com