

**IMPEL™
DaughterCard
Signal
Removal Tool**

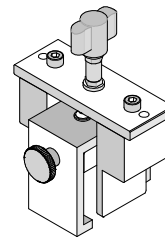

**Application Tooling
Specification Sheet**



Order No. 62100-9820

FEATURES

- This tool is designed for the removal of an IMPEL™ Daughtercard signal module
- Removes Module without damage to the PCB
- Use tool 62201-8976 for inserting 6 pair by 12 column Module assemblies

SCOPE

Products: IMPEL™ Daughtercard signal module, 6 Pair by 12 columns (3.0mm pitch). See Product List below for order numbers.

Product List

The following is a partial list of the product order numbers and their specifications this tool is designed to run. Updates to this list are available on www.molex.com.

Series No.	Column	Guide Style	Daughtercard Header Order No.					
171760	12	Unguided	171760-1022					
		Left	171760-3022	171760-3122	171760-3222	171760-3322	171760-3422	171760-3522
			171760-3622	171760-3722	171760-3822			
		Right	171760-5022	171760-5122	171760-5222	171760-5322	171760-5422	171760-5522
			171760-5622	171760-5722	171760-5822			

DESCRIPTION

Figure 1 illustrates the principal parts of the removal tool.

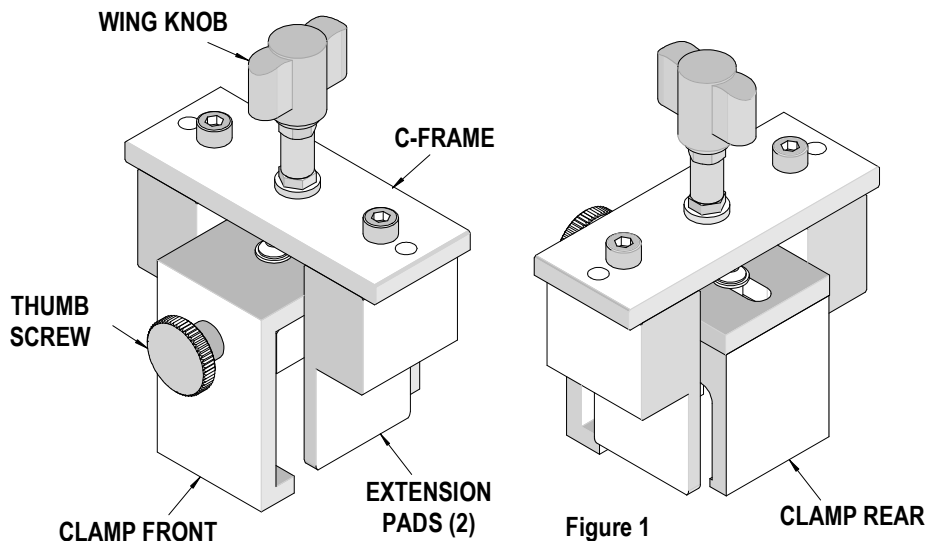
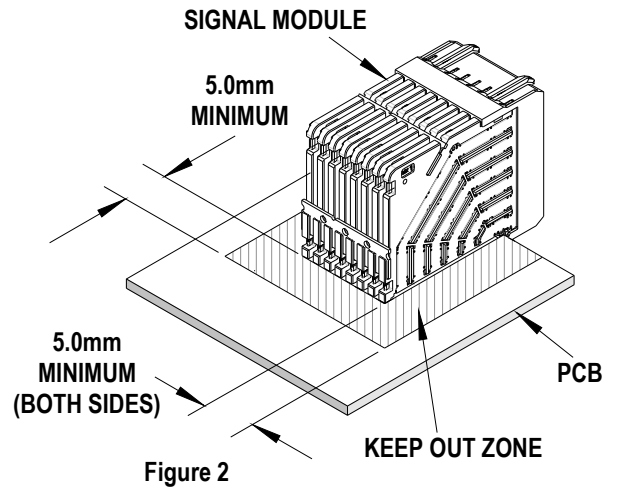

Figure 1

Tool Restrictions

These tools require a "Keep Out Zone" around the Module free of components. The rear of the Module should be 5.00mm (.197"). The right and left sides should be 5.00mm (.197"). See Figure 2. This is a general requirement, regardless of the module being removed.

Note: Be sure that all parts of the removal tool will clear any components on the printed circuit board during use. Tape may also be placed over circuit traces or on the bottom of the PCB Support for added protection of the printed circuit board.



Tool Operation

1. Turn the wing knob counter clockwise so the clamp rear and clamp front are approximately 4mm below the bottom edge of the extension pads. See Figure 3.

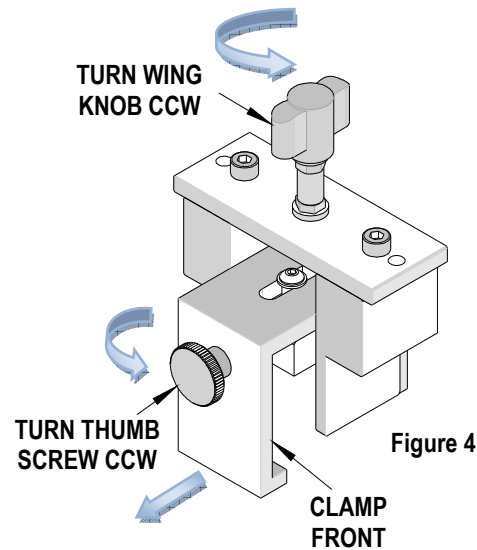
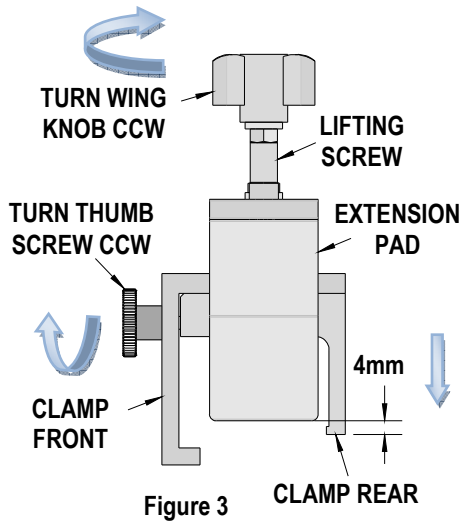

2. Turn the thumb screw counter clockwise so the clamp front can slide forward shown in Figure 4.
3. Position the extractor tool over the outside walls of the Daughtercard module. See figure 5.

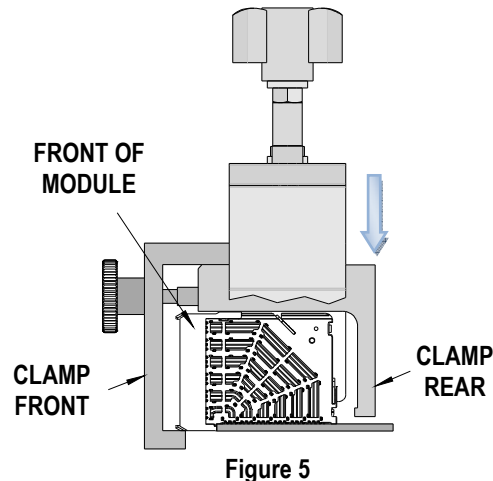

4. Slide the clamp front onto the bottom lip of the front module by turning the thumb screw clockwise. See Figure 6.
5. Continue turning the thumb screw until the clamp rear is pulled into position and is seated in the recessed slots of the clamp rear.

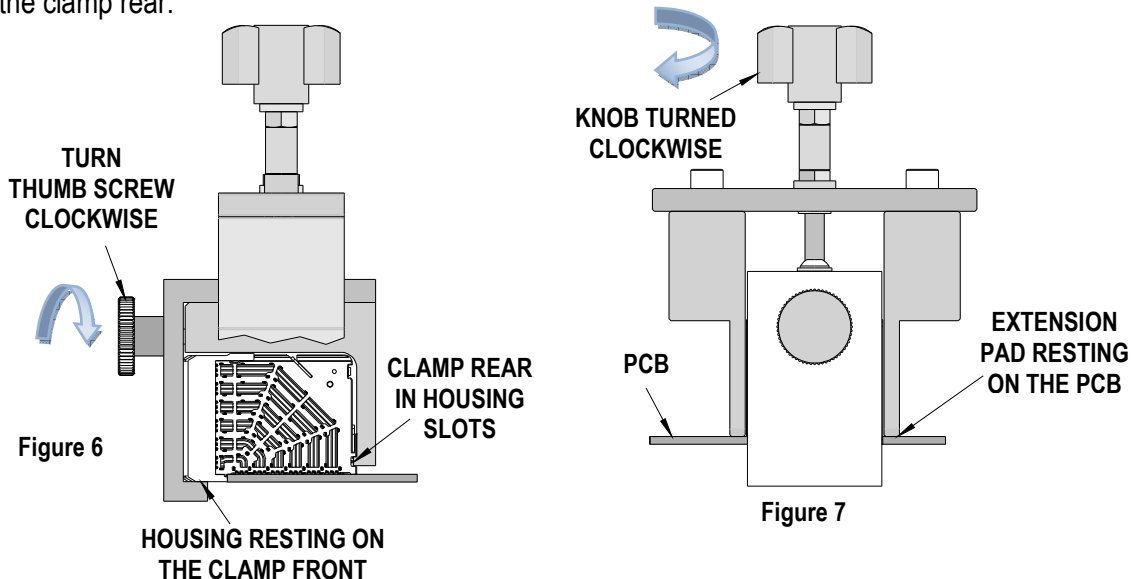

6. Make sure the clamp front and rear are in position before lifting the Daughtercard module off the PCB.
7. Turn the wing knob clockwise (CW) until the extension pads contact the printed circuit board. See Figure 7.
8. Continue turning the wing knob clockwise (CW) until the Daughtercard module is removed from the printed circuit board.
9. Move the extraction tool away from the printed circuit board. Turn the wing knob counter-clockwise (CCW) and turn the thumb screw counterclockwise (CCW) to release the module from the extractor tool. Discard the module.

Note: After the Daughtercard module is removed from the PCB, some terminals may be left in the PCB. This is not a tooling malfunction. If there are terminals left in the PCB use a pair of long nose pliers to remove them carefully so no damage is caused to the PCB. Caution is required when using this method; if a terminal is incorrectly gripped or pulled away at an angle, it could break off inside the PCB hole. After terminals are pulled out of the PCB, they should be discarded. The PCB should be free of any contact debris.

Daughtercard Module Assembly Removal (With Module Assemblies on one side)

When Daughtercard modules are stacked end to end on one side the extractor tool can be converted to allow the removal of the desired daughtercard module.

1. Remove the M5 x 14 long SHCS on the side where the extra module is located. See Figure 8.
2. Rotate the extension pad 180°.
3. Reinstall the M5 x 14 long SHCS thru the hole near the end of the C-frame.
4. Follow the tool operation for removal.

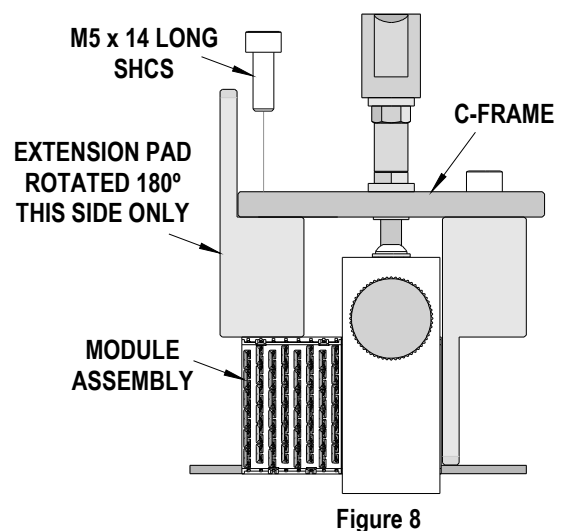

Daughtercard Module Assembly Removal (With Module Assemblies on both sides)

When Daughtercard modules are stacked end to end on both sides the extrator tool can be converted to allow the removal of the desired daughtercard module.

1. Remove the M5 x 14 long SHCS on each the side where the extra modules are located. See Figure 9.
2. Rotate the extension pads 180°.
3. Reinstall the M5 x 14 long SHCS thru the hole near the end of the C-frame.
4. Follow the tool operation for removal.

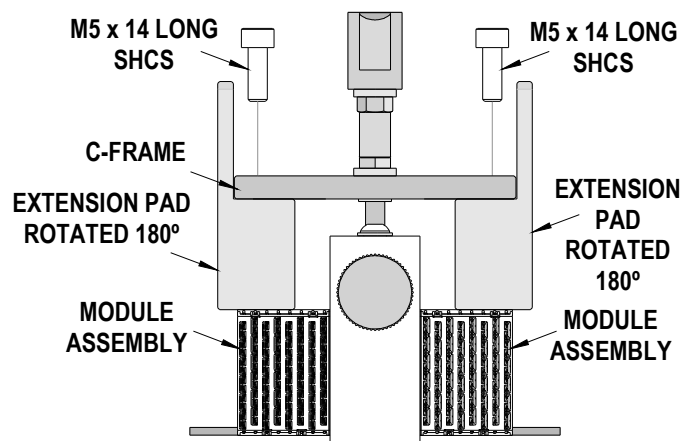

Figure 9

Daughtercard Guided Module Assembly Removal

When removing a Daughtercard with a Guide module the extrator tool can be converted as follows:.

1. Remove the M5 x 14 long SHCS on the side where the guide module is located.
2. Move the extension pad out on this side. See Figure 10.
3. Align the second threaded hole in the extension pad with the C-frame.
4. Reinstall the M5 x 14 long SHCS thru the hole near the end of the C-frame.

NOTE: Remove the screw holding the guide module to the PCB before removing the Daughtercard module.

5. Follow the tool operation for removal.

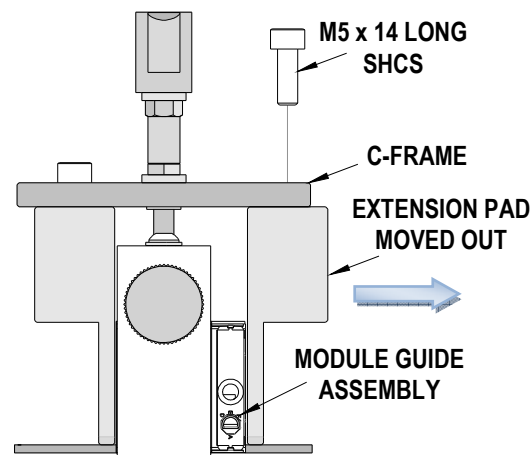

Figure 10

Maintenance

It is recommended that each operator of the tool be made aware of, and responsible for, the following maintenance steps:

1. Remove dust, moisture, and other contaminants with a clean brush, or soft, lint free cloth.
2. Do not use any abrasive materials that could damage the tool.
3. Make certain all pins; pivot points and bearing surfaces are protected with a thin coat of high quality machine oil. Do not oil excessively.
4. When tool is not in use, store in a clean, dry area.

CAUTION: Molex specifications are valid only when used with Molex terminals, applicators and tooling.

Contact Information

For more information on Molex application tooling please contact Molex at 1-800-786-6539.

Visit our Web site at <http://www.molex.com>