

PART NUMBER	REVISION	DESCRIPTION	FEED TYPE
2151210-1	C	FINE CRIMP HEIGHT ADJUST	MECHANICAL
2151210-2	D	FINE CRIMP HEIGHT ADJUST	PNEUMATIC
7-2151210-1	C	MECHANICAL AND CRIMP TOOLING KIT	MECHANICAL
7-2151210-2	D	PNEUMATIC AND CRIMP TOOLING KIT	PNEUMATIC
7-2151210-7	A	CRIMP TOOLING KIT	-

ATLANTIC VERSION TERMINATOR INTERFACE ADAPTER

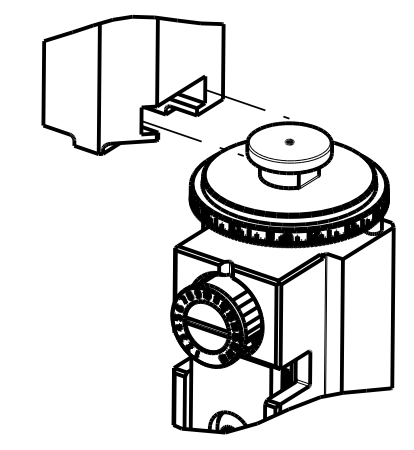

APPLICATOR DATA		
CRIMP	SIZE	TYPE
WIRE	.090 [2.29 mm]	F
INSUL	.130 [3.30 mm]	F

APPLICATOR INSTRUCTIONS
408-35042

TERMINAL DATA: TE TERMINAL		TE CRIMP SPECIFICATION	
TERMINAL NAME: PIN & SOCKET MATE-N-LOK			
WIRE STRIP LENGTH		INSULATION DIAMETER RANGE	
.154-.185 IN [3.90-4.70 mm]		Ø.070-.130 IN [1.78-3.30 mm]	
TERMINAL APPLICATION SPECIFICATION	114-3118		
TERMINALS APPLIED			
TE TERMINAL	TE TERMINAL	TE TERMINAL	TE TERMINAL
163300-5	163300-6	163300-7	163300-8
163301-6	163301-8		

WIRE SIZE	CRIMP HEIGHT mm [INCH]	CRIMP HEIGHT REFERENCE SETTING
1.00mm2	1.30+/-0.05 [1.051+/-0.002]	5.3
0.75mm2	1.24+/-0.05 [1.049+/-0.002]	5.9
0.50mm2	1.19+/-0.03 [1.047+/-0.001]	6.5

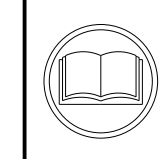

- 1 RECOMMENDED SPARE PARTS
- 2 REFER TO SUPPLIED INSTRUCTION SHEET FOR CLEANING, LUBRICATION AND STORAGE OF APPLICATOR.
- 3 APPLY PART NUMBER 2-23419-6 LOCTITE TO THREADS OF ITEM 242. APPLY PART NUMBER 1-23419-5 LOCTITE TO THREADS OF ITEM 50.
- 4 CRIMP HEIGHT REFERENCE SETTING WAS THE SETTING USED WHEN THE APPLICATOR WAS QUALIFIED AT THE FACTORY. ADJUSTMENT MAY BE NECESSARY WHEN RUNNING APPLICATOR IN THE FIELD.
- 5. UNLESS SPECIFIED OTHERWISE TORQUE VALUES SHALL BE USED PER DOCUMENT, 101-35000.

***WARNING**
ON INSTALLATION, SET WIRE DISC TO CRIMP HEIGHT REFERENCE SETTING FOR LARGEST WIRE SIZE. CRIMP HEIGHT REFERENCE SETTINGS GREATER THAN THE VALUE SHOWN MAY CAUSE DAMAGE TO THE CRIMP TOOLING. REFER TO THE INSTRUCTION SHEET FOR PROPER SETUP AND ADJUSTMENTS.

ATLANTIC VERSION
Shown on sheets 1 of 4 & 2 of 4
(Pacific version shown on sheets 3 of 4 & 4 of 4)

LOC	DIST	REVISIONS			
A	66	REV	DATE	BY	APPV
		A	RELEASED	15MAR2012	KH SX
		B	ECR-14-008807	12JUN2014	KH TE
		C	ECR-19-002145	10FEB2019	TB CT
		D	ECR-20-014320	09OCT2020	FZ TE

-	1	-	1	-	2119641-1	FEED CAM, AIR FEED	248
-	1	1	1	1	2119082-9	CAM, SNAIL, INSULATION ADJUSTMENT	244
-	1	1	1	1	2079764-1	WASHER, WAVE SPRING, CREST-TO-CREST	243
-	1	1	1	1	2119083-1	RETAINER, INSULATION DIAL	242
-	1	1	1	1	7-18023-7	SCR, SKT HD CAP M3 X 4.0	241
-	-	1	-	-	2119580-1	MECHANICAL FEED ASSEMBLY	239
-	1	-	1	-	2844940-1	AIR FEED MODULE	238
-	2	2	2	2	1-2079383-0	SCR, BHSC, RoHS (M3 X 6)	230
-	1	1	1	1	1976053-7	LOCATER BLOCK, TERMINAL	179
-	1	1	1	1	6-993111-6	PIN, SLOTTED SPRING 3.0 X 14.0	177
-	1	1	1	1	8-22280-7	SPRING, COMPRESSION	176
-	1	1	1	1	1752353-2	GUIDE PIN, HOLDDOWN	175
-	1	1	1	1	1901680-2	GUIDE PIN, HOLDDOWN	174
-	REF	REF	REF	REF	994970-2	COUNTER, MAGNETIC	164
-	1	1	1	1	2844908-1	SCREW, LOCKING	99
-	1	1	1	1	2844907-1	POST, LOCKING	98
-	1	1	1	1	455888-5	SPACER, CRIMPER	82
-	1	1	1	1	1803607-3	DOCUMENTATION PACKAGE	71
-	1	1	1	1	2119740-1	TAG, IDENTIFICATION	67
-	2	2	2	2	2168078-1	SCREW, DRIVE, RH, RoHS, 2 x .188	66
-	1	1	1	1	2168083-2	SCR, SKT HD CAP, RoHS, M4 X 8.0	60
-	1	1	1	1	5-18022-5	SCR, HEX HD CAP, M4 X 6.0	59
-	1	1	1	1	1338685-1	PAWL, FEED	56
-	4	4	4	4	2168083-3	SCR, SKT HD CAP, RoHS, M4 X 12.0	54
-	1	1	1	1	1-5018030-0	NUT, HEX, REG, RoHS, M3.5	52
-	1	1	1	1	1901681-8	HOLDDOWN, TERMINAL	51
-	1	1	1	1	1-1752354-2	STANDOFF, HOLD-DOWN	50
-	1	2	1	2	18023-9	SCR, SKT HD CAP M4 X 6.0	49
-	-	1	-	-	2119652-1	FEED CAM, PRE FEED	48
-	-	1	-	-	2119653-1	FEED CAM, POST FEED	47
-	1	1	1	1	1803583-9	APPLICATOR BASIC ASSEMBLY, SF	46
-	1	1	1	1	1803515-3	RAM ASSEMBLY, SF ATLANTIC	44
-	1	1	1	1	1803602-1	SCR, BHSC, RoHS (M8 X 25)	41
-	1	1	1	1	1752356-3	SUPPORT, TERMINAL	34
-	2	2	2	2	2079383-5	SCR, BHSC, RoHS (M4 X 20)	33
-	2	2	2	2	2-2844962-8	SPACER, CYLINDRICAL, STRIP GUIDE	30
-	1	1	1	1	2844992-1	ASSEMBLY, STRIP GUIDE	29
-	1	1	1	1	1-455888-7	SPACER, CRIMPER	28
-	1	1	1	1	1320928-2	STRIP GUIDE	24
-	1	1	1	1	2168083-2	SCR, SKT HD CAP, RoHS, M4 X 8.0	21
-	2	2	2	2	1-18028-2	WASHER, FLAT, REG M4	20
-	1	1	1	1	2119533-1	STRIPPER, SIDE FEED	19
-	1	1	1	1	2119806-1	INSERT, SHEAR	13
-	1	1	1	1	3-22280-3	SPRING, COMPRESSION	12
-	1	1	1	1	1-356885-4	STOP, SHEAR	11
-	1	1	1	1	2119805-1	SHEAR HOLDER, FRONT	10
-	1	1	1	1	1803095-6	FLOATING SHEAR, FRONT	9
-	1	2	2	1	1-1333205-5	ANVIL, COMBINATION	8
-	-	-	-	-	-	-	7
-	-	-	-	-	-	-	6
-	1	1	1	1	2119757-8	DEPRESSOR, SHEAR	5
-	1	1	1	1	1-238011-7	BLOCK, CRIMPER SPACER	4
-	1	2	2	1	1-1633961-5	CRIMPER, INSULATION F PREMIUM	3
-	1	1	1	1	455888-2	SPACER, CRIMPER	2
-	1	2	2	1	3-456406-0	CRIMPER, WIRE PREMIUM	1
-	77	72	71	-2	-1	PART NO	ITEM NO

DIMENSIONS:		TOLERANCES UNLESS OTHERWISE SPECIFIED:		DWG		TE Connectivity	
mm	0 PLC ±	1 PLC ±	2 PLC ±	3 PLC ±	4 PLC ±	5 PLC ±	6 PLC ±
	ANGLES	FINISH		APV		NAME	
				S. XI		Ocean Side Feed Applicator	
				I. CRUZ		SIZE CAGE CODE DRAWING NO	
				28OCT2011		A1 00779 C=2151210	
				28OCT2011		RESTRICTED TO	
				APV		Customer Accessible Production Drawing	
				SCALE		SHEET 1 OF 4 REV D	

LOC		DIST		REVISIONS			
A	66	P	LYM	DESCRIPTION	DATE	DWN	APVD
		-		SEE SHEET 1	-	-	-

FEED TYPE MECHANICAL

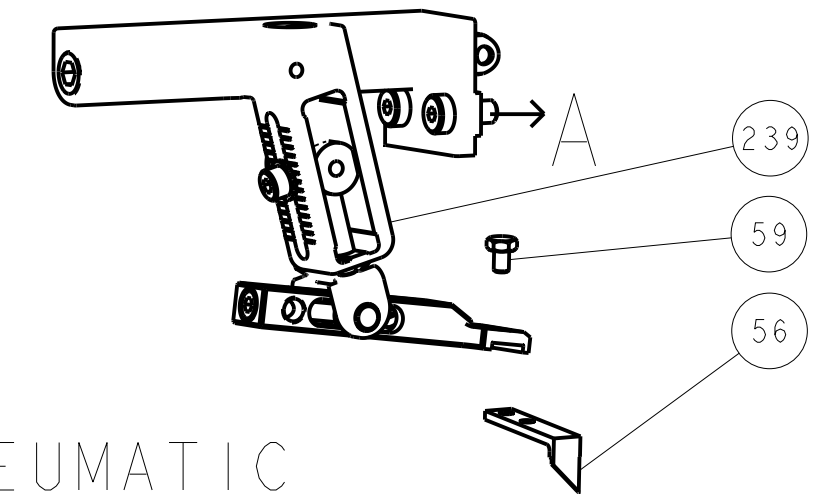

PNEUMATIC

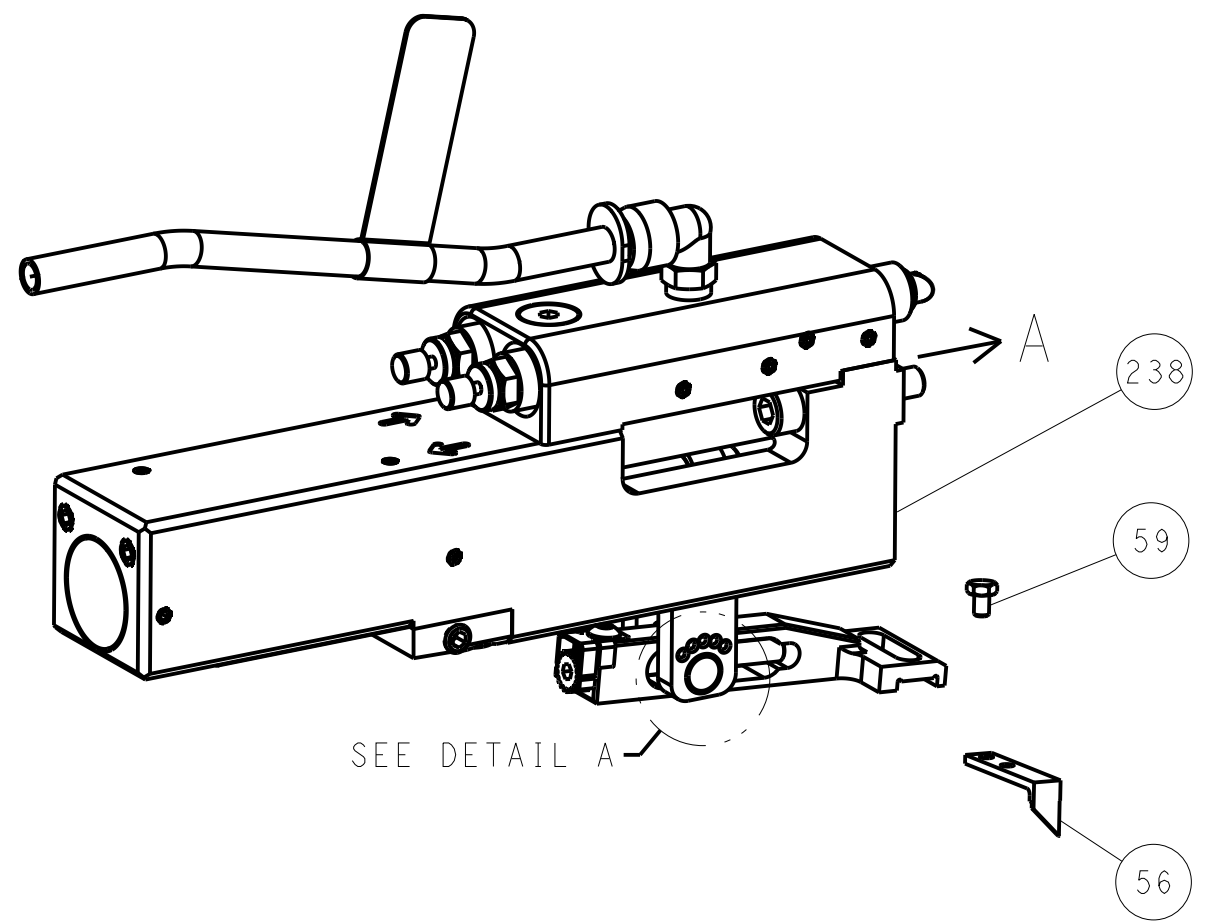

FEED SPRING SETTING POSITION (SHOWN FROM REAR SIDE)

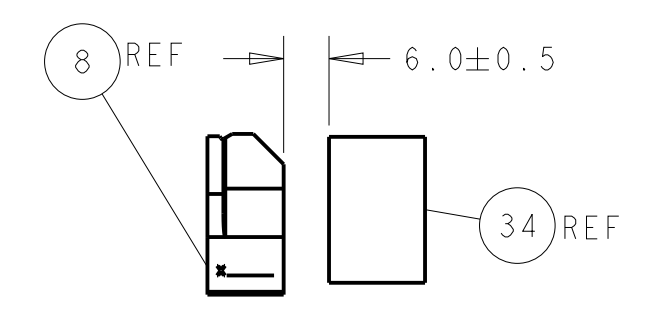
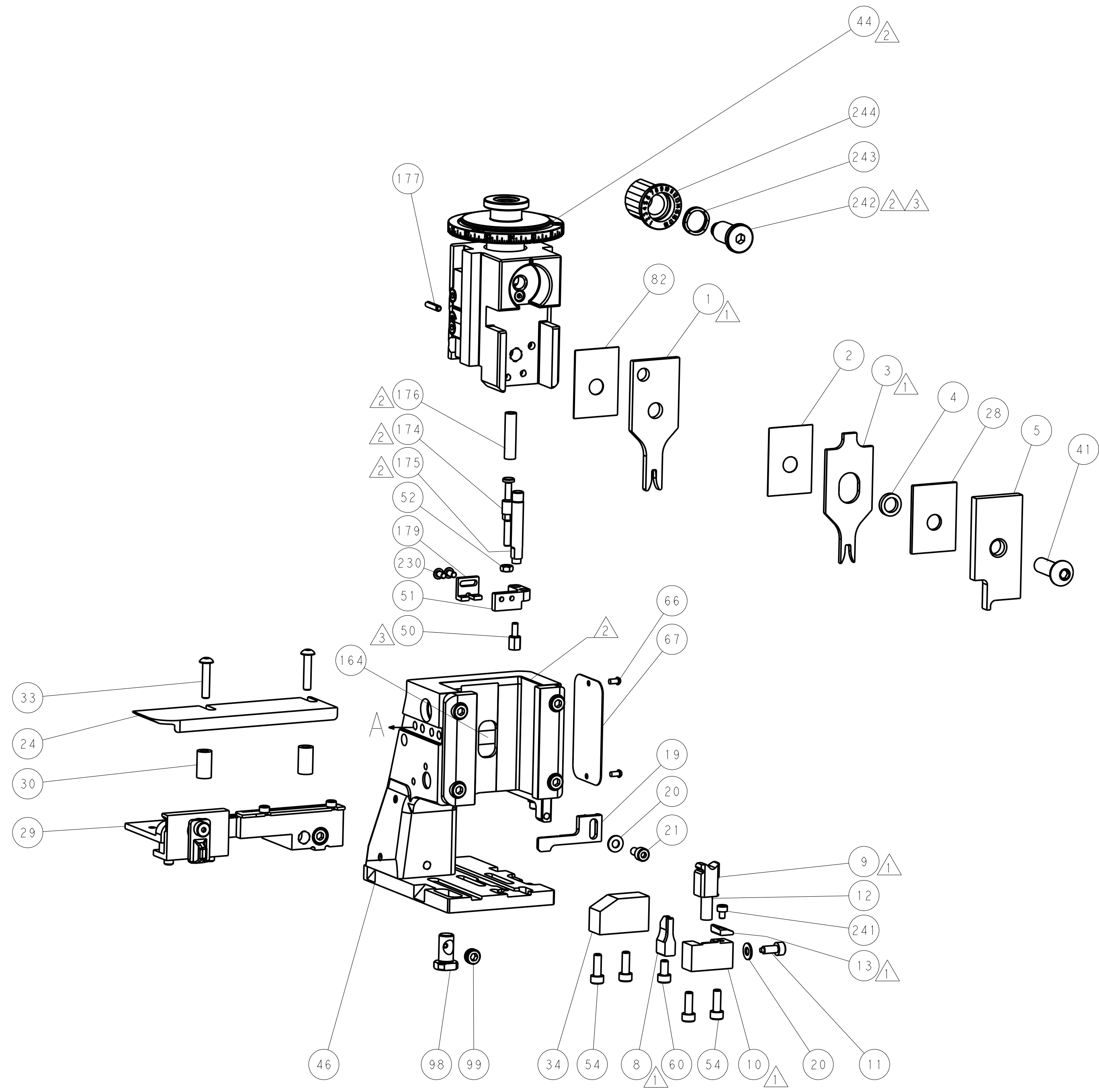
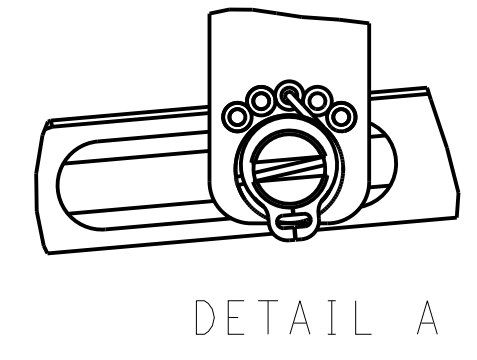

TERMINAL SUPPORT LOCATION

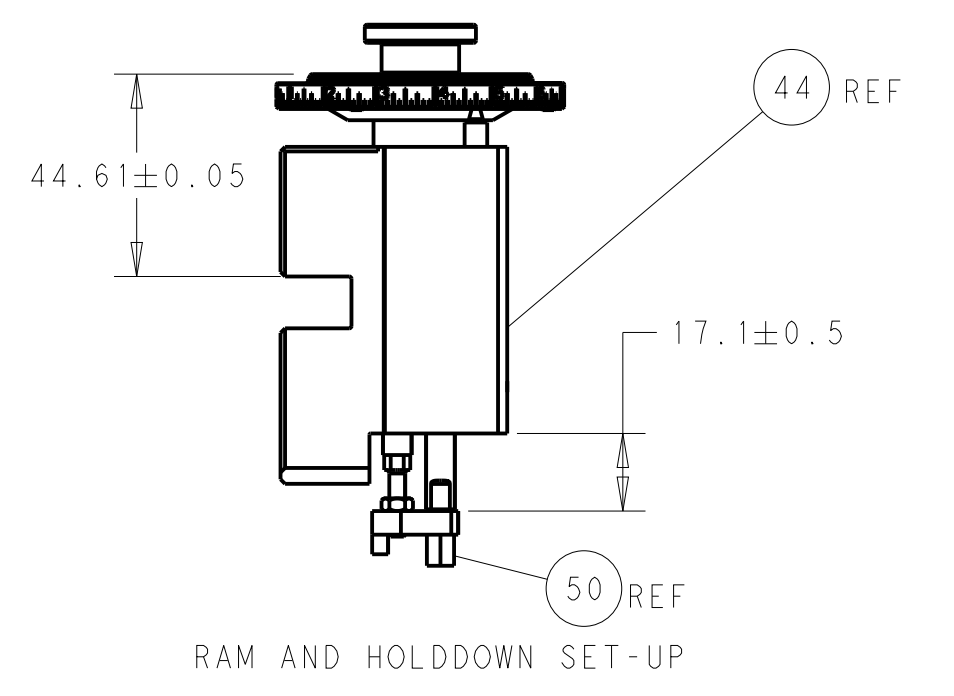

RAM AND HOLDDOWN SET-UP

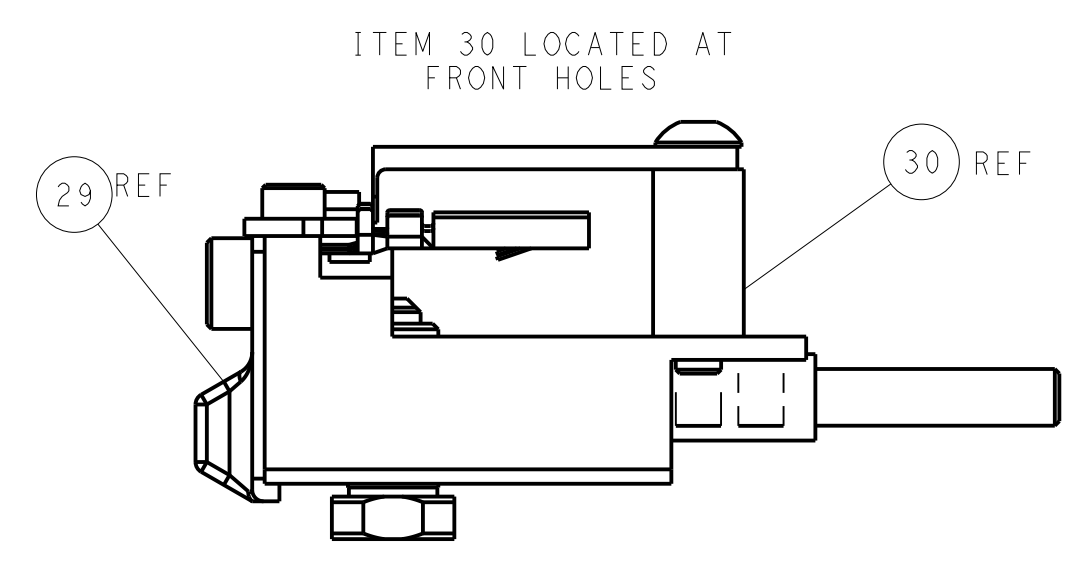

FEED TRACK POSITION GUIDE BY INSULATION BARREL

CAM POSITIONS

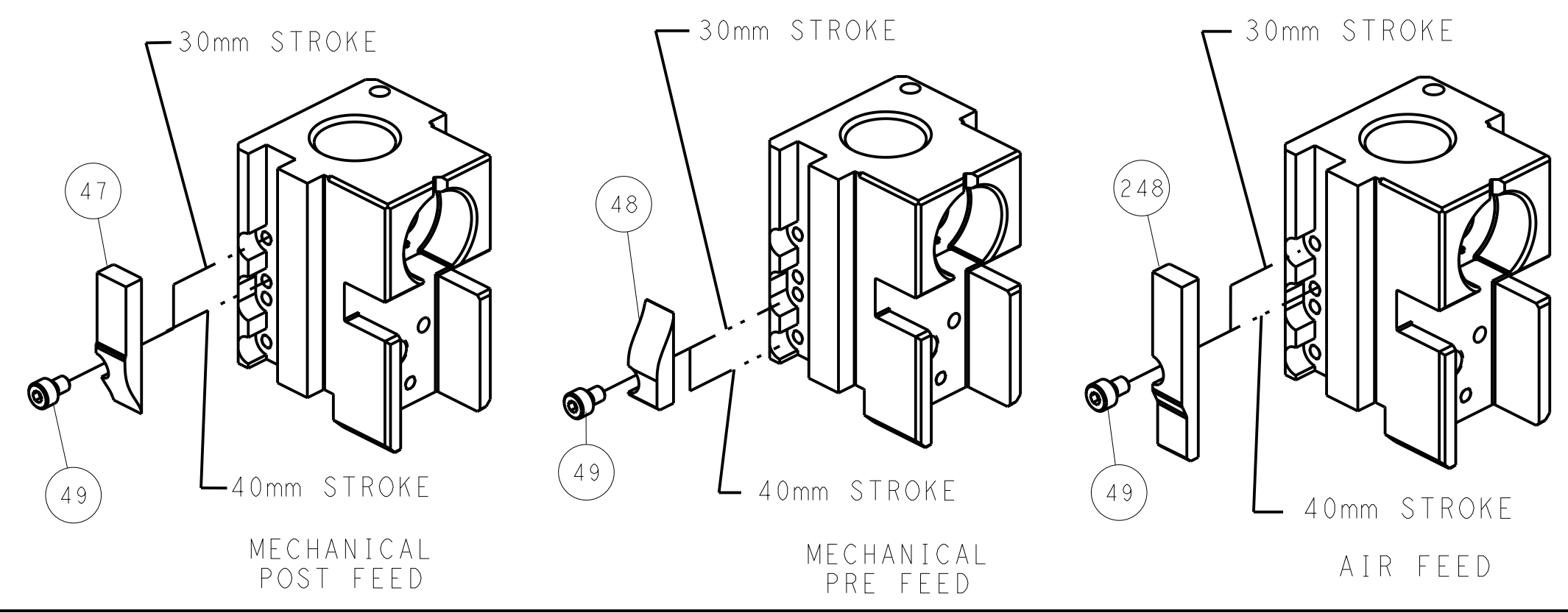

ATLANTIC VERSION
 Shown on sheets 1 of 4 & 2 of 4
 (Pacific version shown on sheets 3 of 4 & 4 of 4)

DIMENSIONS:		TOLERANCES UNLESS OTHERWISE SPECIFIED:		DWN H. HUANG 28OCT2011		TE Connectivity Harrisburg, PA 17105-3608	
mm	0 PLC	±		CHK S. XI 28OCT2011	NAME	Ocean Side Feed Applicator	
	1 PLC	±		APVD J. CRUZ 28OCT2011	PRODUCT SPEC	RESTRICTED TO	
	2 PLC	±			APPLICATION SPEC	SIZE CAGE CODE DRAWING NO	
	3 PLC	±			WEIGHT	A1 00779 ©=2151210	
	4 PLC	±			MATERIAL	Customer Accessible Production Drawing	
	ANGLES	±			FINISH	SCALE 1:2 SHEET 2 OF 4 REV D	

PART NUMBER	REVISION	DESCRIPTION	FEED TYPE
2-2151210-1	C	FINE CRIMP HEIGHT ADJUST	MECHANICAL
2-2151210-2	D	FINE CRIMP HEIGHT ADJUST	PNEUMATIC
7-2151210-7	A	CRIMP TOOLING KIT	-

PACIFIC VERSION TERMINATOR
INTERFACE ADAPTER

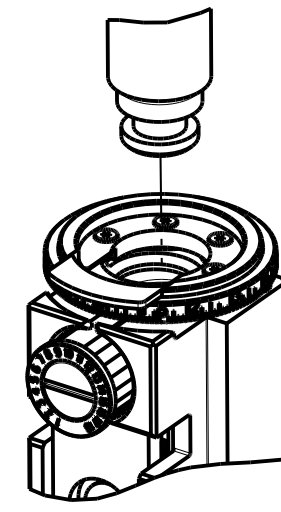

APPLICATOR DATA		
CRIMP	SIZE	TYPE
WIRE	.090 [2.29 mm]	F
INSUL	.130 [3.30 mm]	F

APPLICATOR INSTRUCTIONS
408-35042

TERMINAL DATA: TE TERMINAL		TE CRIMP SPECIFICATION	
TERMINAL NAME: PIN & SOCKET MATE-N-LOK			
WIRE STRIP LENGTH		INSULATION DIAMETER RANGE	
.154-.185 IN [3.90-4.70 mm]		∅.070-.130 IN [1.78-3.30 mm]	
TERMINAL APPLICATION SPECIFICATION	114-3118		
TERMINALS APPLIED			
TE TERMINAL	TE TERMINAL	TE TERMINAL	TE TERMINAL
163300-5	163300-6	163300-7	163300-8
163301-6	163301-8		

WIRE SIZE	CRIMP HEIGHT mm [INCH]	CRIMP HEIGHT REFERENCE SETTING
1.00mm2	1.30+/-0.05 [1.051+/-0.002]	5.3
0.75mm2	1.24+/-0.05 [1.049+/-0.002]	5.9
0.50mm2	1.19+/-0.03 [1.047+/-0.001]	6.5

- RECOMMENDED SPARE PARTS
- REFER TO SUPPLIED INSTRUCTION SHEET FOR CLEANING, LUBRICATION AND STORAGE OF APPLICATOR.
- APPLY PART NUMBER 2-23419-6 LOCTITE TO THREADS OF ITEM 242. APPLY PART NUMBER 1-23419-5 LOCTITE TO THREADS OF ITEM 50.
- CRIMP HEIGHT REFERENCE SETTING WAS THE SETTING USED WHEN THE APPLICATOR WAS QUALIFIED AT THE FACTORY. ADJUSTMENT MAY BE NECESSARY WHEN RUNNING APPLICATOR IN THE FIELD.
- 5. UNLESS SPECIFIED OTHERWISE TORQUE VALUES SHALL BE USED PER DOCUMENT, 101-35000.

***WARNING**
ON INSTALLATION, SET WIRE DISC TO CRIMP HEIGHT REFERENCE SETTING FOR LARGEST WIRE SIZE. CRIMP HEIGHT REFERENCE SETTINGS GREATER THAN THE VALUE SHOWN MAY CAUSE DAMAGE TO THE CRIMP TOOLING. REFER TO THE INSTRUCTION SHEET FOR PROPER SETUP AND ADJUSTMENTS.

LOC	DIST	REV	DATE	BY	APPV
A	66				

REV	DATE	DESCRIPTION	ITEM NO		
-	1	1	2119082-9	CAM, SNAIL, INSULATION ADJUSTMENT	244
-	1	1	2079764-1	WASHER, WAVE SPRING, CREST-TO-CREST	243
-	1	1	2119083-1	RETAINER, INSULATION DIAL	242
-	1	1	7-18023-7	SCR, SKT HD CAP M3 X 4.0	241
-	-	1	2119580-1	MECHANICAL FEED ASSEMBLY	239
-	1	-	2844940-1	AIR FEED MODULE	238
-	2	2	1-2079383-0	SCR, BHSC, RoHS (M3 X 6)	230
-	1	1	1976053-7	LOCATER BLOCK, TERMINAL	179
-	1	1	6-993111-6	PIN, SLOTTED SPRING 3.0 X 14.0	177
-	1	1	8-22280-7	SPRING, COMPRESSION	176
-	1	1	1752353-2	GUIDE PIN, HOLDDOWN	175
-	1	1	1901680-2	GUIDE PIN, HOLDDOWN	174
-	REF	REF	994970-2	COUNTER, MAGNETIC	164
-	1	-	2119641-2	FEED CAM, AIR FEED	151
-	1	1	2168083-8	SCR, SKT HD CAP, RoHS, M4 X 16	144
-	4	4	2168083-9	SCR, SKT HD CAP, RoHS, M4 X 20	143
-	-	1	2119653-2	FEED CAM, POST FEED	142
-	1	1	1-1803583-0	APPLICATOR BASIC ASSEMBLY, SF	141
-	1	1	1803516-3	RAM ASSEMBLY, SF PACIFIC	140
-	1	1	2844908-1	SCREW, LOCKING	99
-	1	1	2844907-1	POST, LOCKING	98
-	1	1	455888-5	SPACER, CRIMPER	82
-	1	1	1803607-3	DOCUMENTATION PACKAGE	71
-	1	1	2119740-1	TAG, IDENTIFICATION	67
-	2	2	2168078-1	SCREW, DRIVE, RH, RoHS, 2 x .188	66
-	1	1	5-18022-5	SCR, HEX HD CAP, M4 X 6.0	59
-	1	1	1338685-1	PAWL, FEED	56
-	1	1	1-5018030-0	NUT, HEX, REG, RoHS, M3.5	52
-	1	1	1901681-8	HOLDDOWN, TERMINAL	51
-	1	1	1-1752354-2	STANDOFF, HOLD-DOWN	50
-	1	2	18023-9	SCR, SKT HD CAP M4 X 6.0	49
-	-	1	2119652-1	FEED CAM, PRE FEED	48
-	1	1	1803602-1	SCR, BHSC, RoHS (M8 X 25)	41
-	1	1	1752356-3	SUPPORT, TERMINAL	34
-	2	2	2079383-5	SCR, BHSC, RoHS (M4 X 20)	33
-	2	2	2-2844962-8	SPACER, CYLINDRICAL, STRIP GUIDE	30
-	1	1	2844992-1	ASSEMBLY, STRIP GUIDE	29
-	1	1	1-455888-7	SPACER, CRIMPER	28
-	1	1	1320928-2	STRIP GUIDE	24
-	1	1	2168083-2	SCR, SKT HD CAP, RoHS, M4 X 8.0	21
-	2	2	1-18028-2	WASHER, FLAT, REG M4	20
-	1	1	2119533-1	STRIPPER, SIDE FEED	19
-	1	1	2119806-1	INSERT, SHEAR	13
-	1	1	3-22280-3	SPRING, COMPRESSION	12
-	1	1	1-356885-4	STOP, SHEAR	11
-	1	1	2119805-1	SHEAR HOLDER, FRONT	10
-	1	1	1803095-6	FLOATING SHEAR, FRONT	9
-	1	1	1-1333205-5	ANVIL, COMBINATION	8
-	-	-	-	-	7
-	-	-	-	-	6
-	1	1	2119757-8	DEPRESSOR, SHEAR	5
-	1	1	1-238011-7	BLOCK, CRIMPER SPACER	4
-	1	1	1-1633961-5	CRIMPER, INSULATION F PREMIUM	3
-	1	1	455888-2	SPACER, CRIMPER	2
-	1	1	3-456406-0	CRIMPER, WIRE PREMIUM	1

PACIFIC VERSION
Shown on sheets 3 of 4 & 4 of 4
(Atlantic version shown on sheets 1 of 4 & 2 of 4)

DIMENSIONS: mm		TOLERANCES UNLESS OTHERWISE SPECIFIED:		DWG: H. HUANG 28OCT2011		CHK: S.XI 28OCT2011		APVD: J. CRUZ 28OCT2011		NAME: TE Connectivity Harrisburg, PA 17105-3608	
0 PLC ±		1 PLC ±		2 PLC ±		3 PLC ±		4 PLC ±		RESTRICTED TO:	
MATERIAL:		FINISH:		WEIGHT:		SCALE: 1:2		SHEET 3 OF 4		REV D	

LOC	DIST	REV	DATE	BY	APPV
A	66				
REVISIONS			DATE	BY	APPV
- SEE SHEET 1			-	-	-

FEED TYPE MECHANICAL

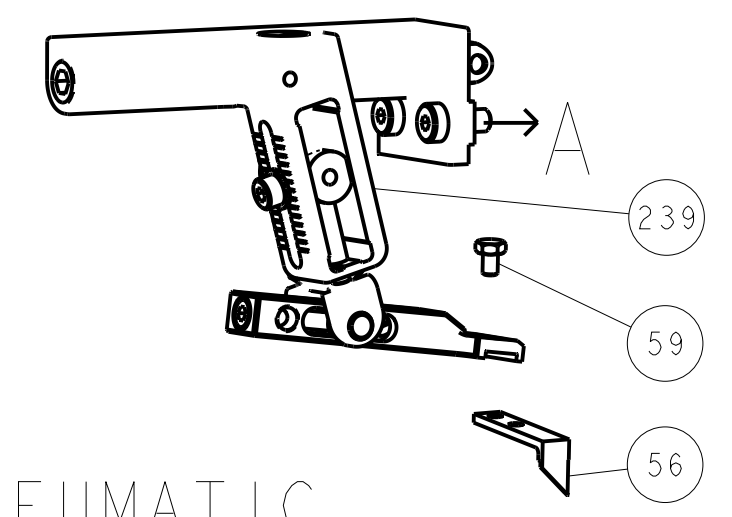

PNEUMATIC

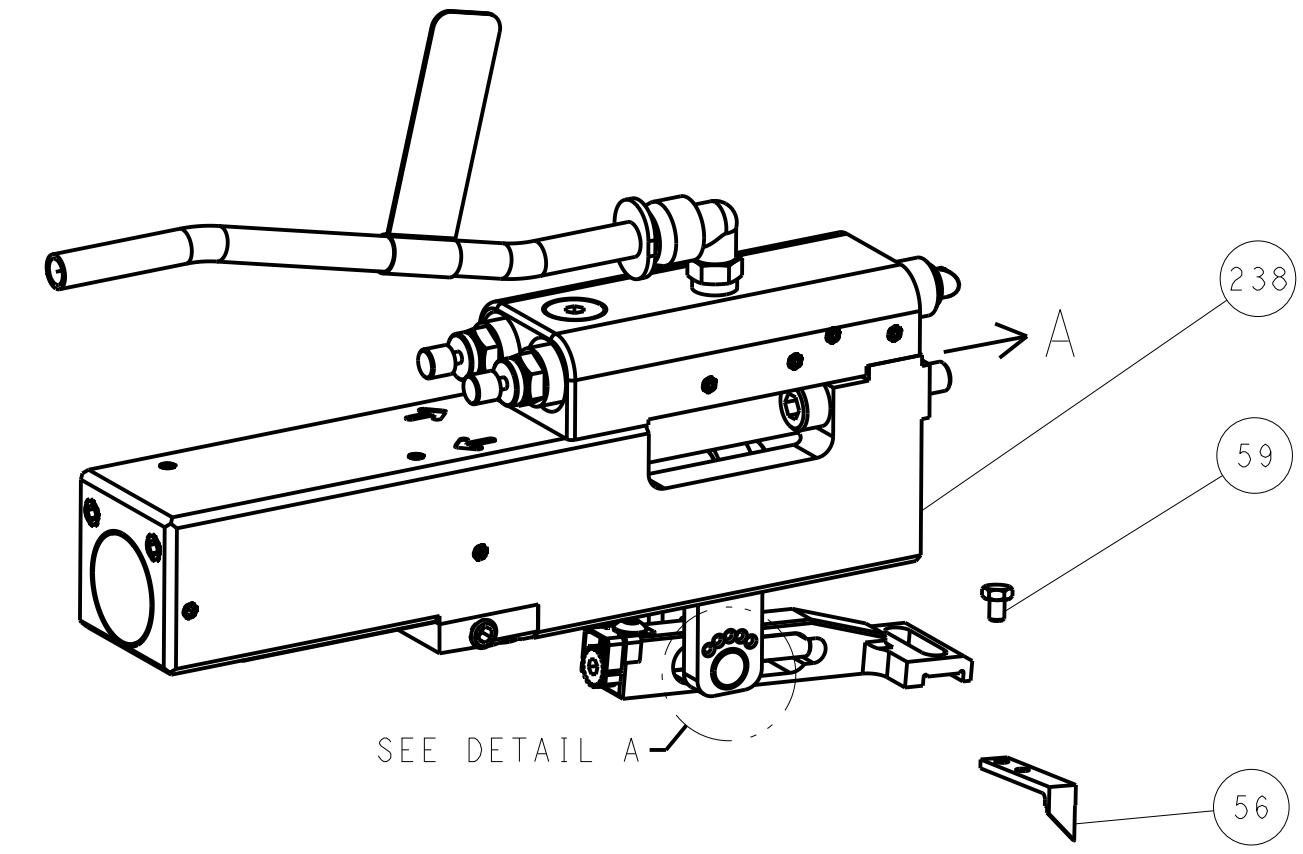

FEED SPRING SETTING POSITION (SHOWN FROM REAR SIDE)

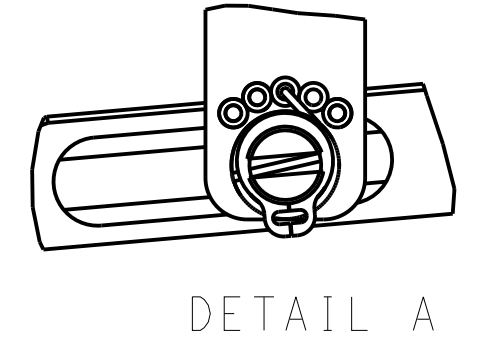

CAM POSITIONS

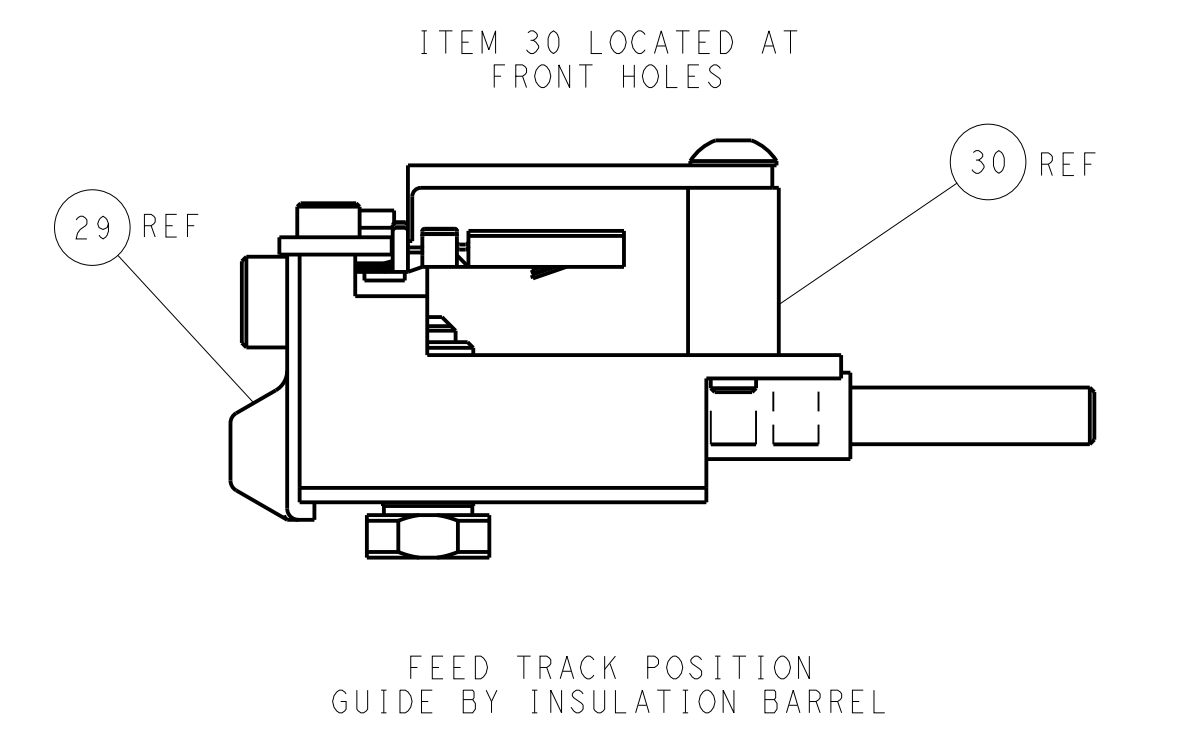
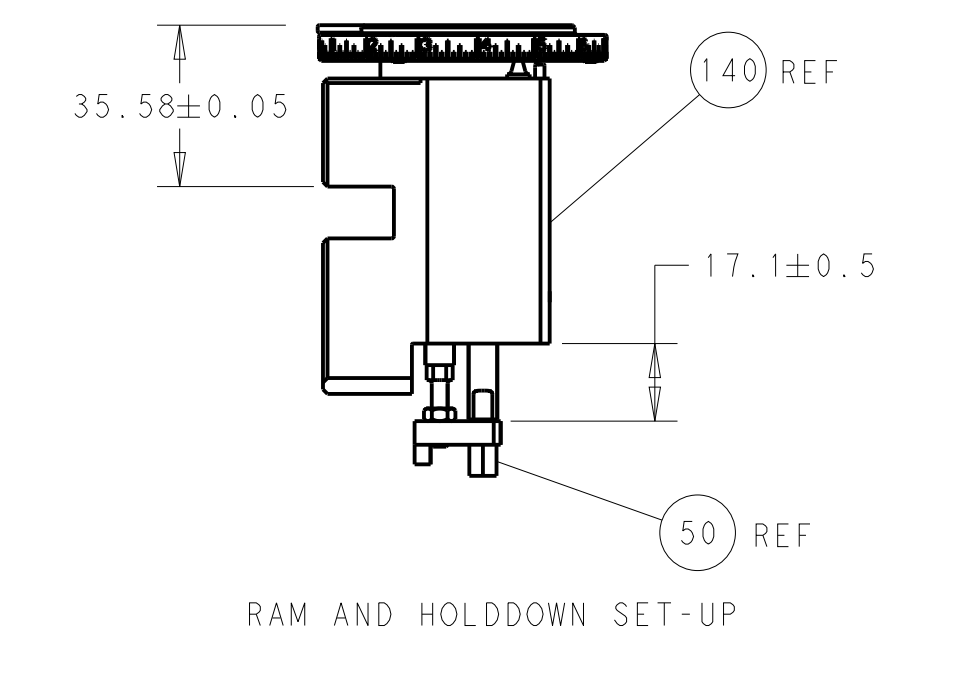
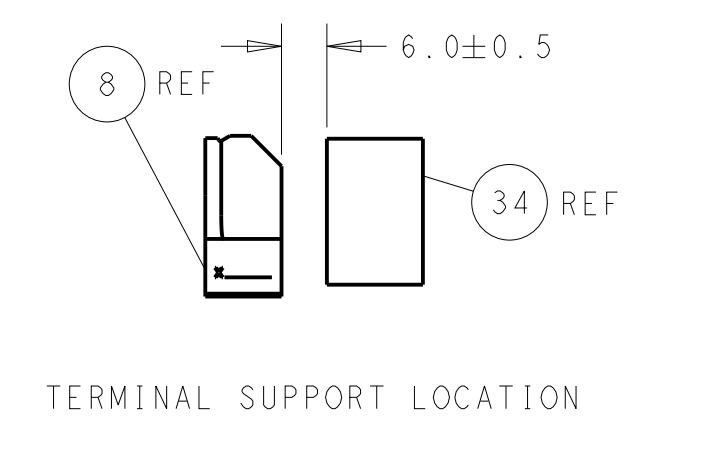
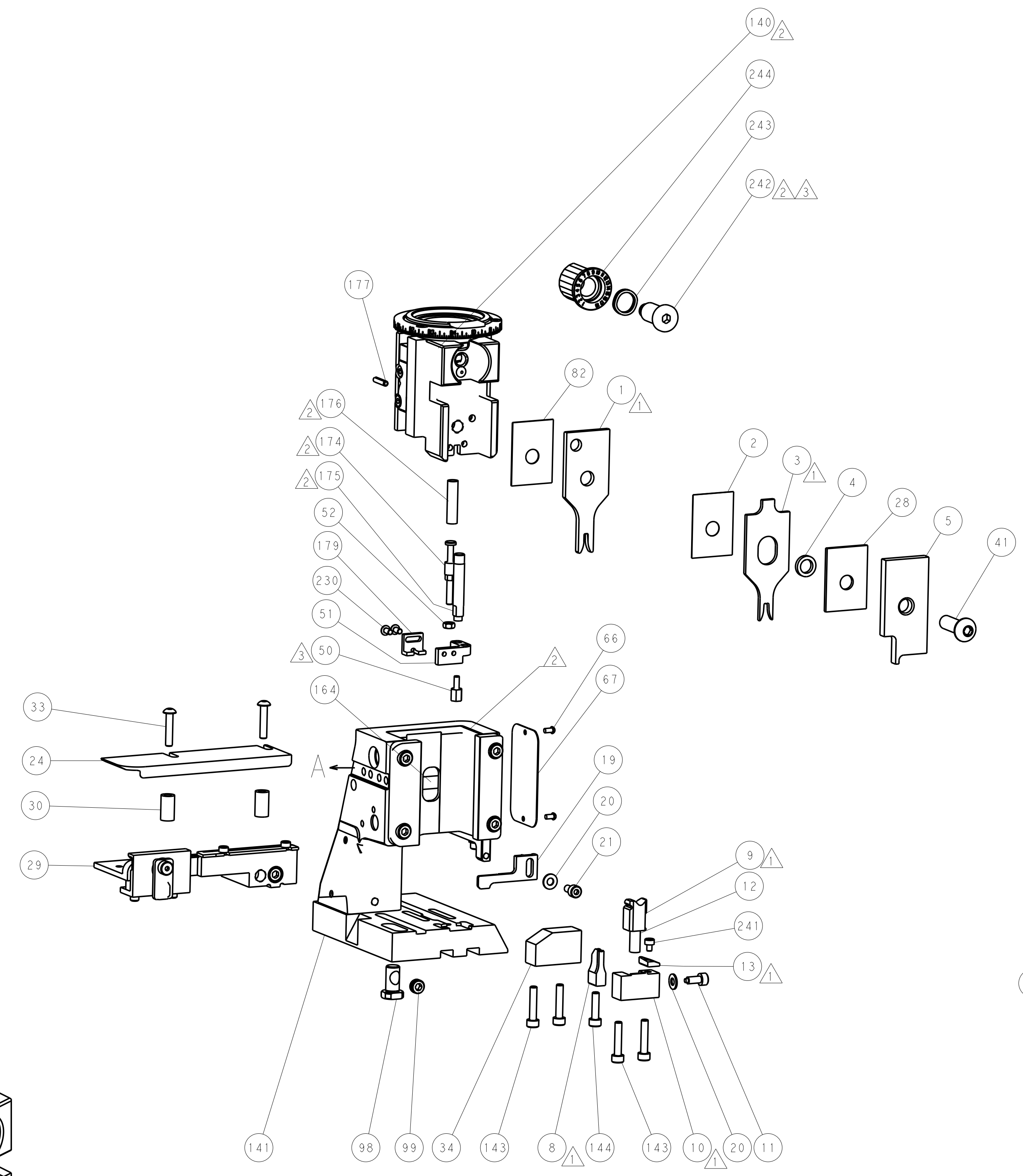
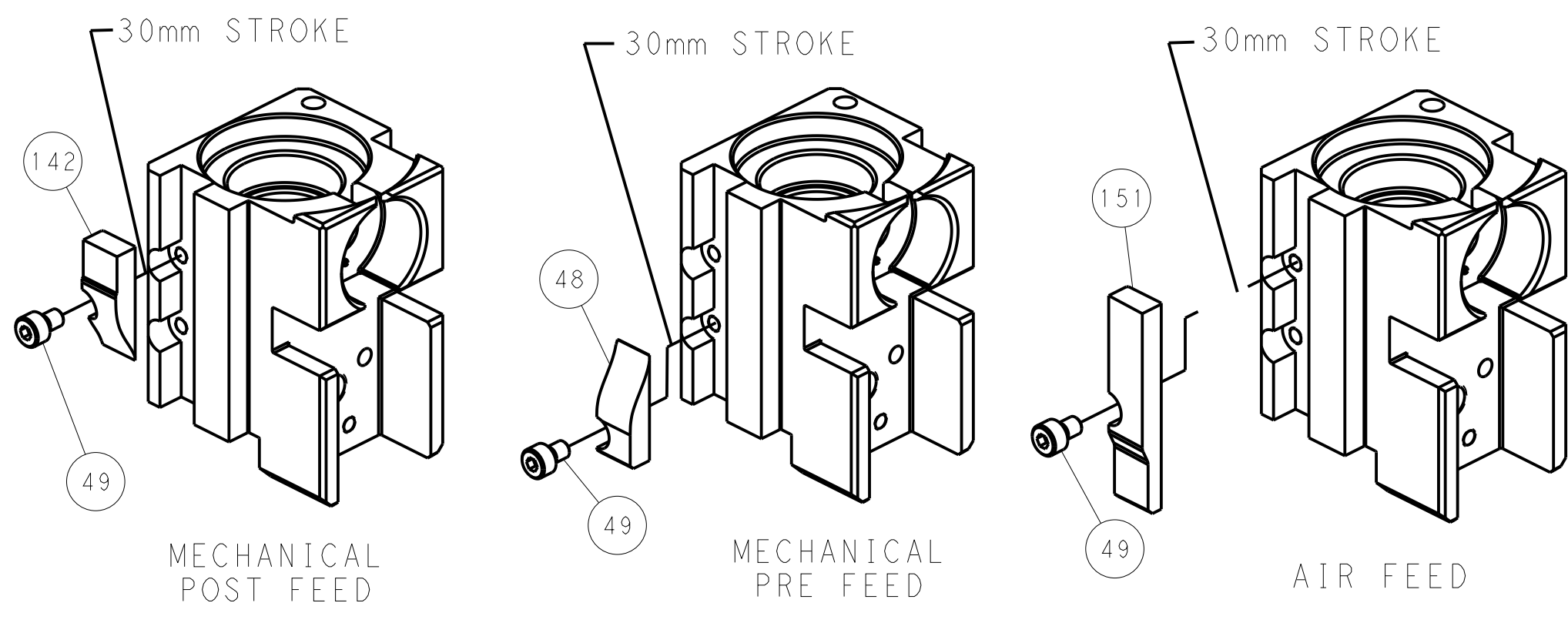

PACIFIC VERSION
 Shown on sheets 3 of 4 & 4 of 4
 (Atlantic version shown on sheets 1 of 4 & 2 of 4)

DIMENSIONS:		TOLERANCES UNLESS OTHERWISE SPECIFIED:		DWN H. HUANG 28OCT2011		STE TE Connectivity	
mm	0 PLC ±	1 PLC ±	2 PLC ±	3 PLC ±	4 PLC ±	5 PLC ±	Harrisburg, PA 17105-3608
	ANGLES			CHK S. XI 28OCT2011	NAME	Ocean Side Feed Applicator	
MATERIAL	FINISH	WEIGHT	SCALE	APVD J. CRUZ 28OCT2011	PRODUCT SPEC	SIZE	RESTRICTED TO
			1:2		APPLICATION SPEC	CAGE CODE DRAWING NO	
						A1 00779 ©=2151210	
						Customer Accessible Production Drawing	
						SHEET 4 OF 4	REV D