

REVISIONS					
P	LTR	DESCRIPTION	DATE	DWN	APVD
J4		REVISED PER ECN-22-150900	27APR2022	RK	CSD

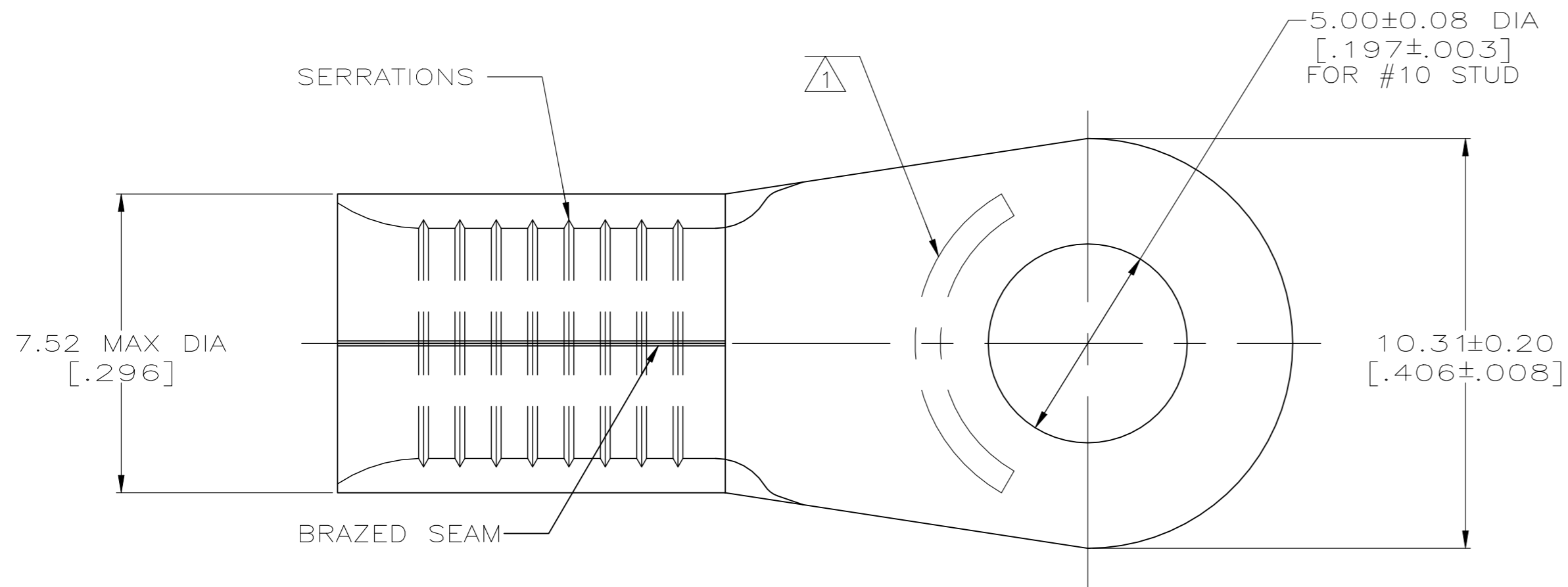

AMP WIRE RANGE	Listed FILE E13288	LR7189 Certified
8 AWG SOLID OR STRANDED	8 AWG STRANDED	8 AWG SOLID OR STRANDED

- 1 STAMP AMP 8* APPROX AS SHOWN
- 2 COPPER PER ASTM B-152, ANNEALED
- 3 0.00254 [.000100] MIN TIN PLATE PER ASTM B-545
- 4 LONGER WIRE BARREL THAN OTHER #8 AWG, PROPER WIRE STRIP LENGTH: 9.12-9.94 [.359-.390]; IGNORE TOOLING INSTRUCTION SHEET STRIP LENGTH
- 5 NOTE DELETED

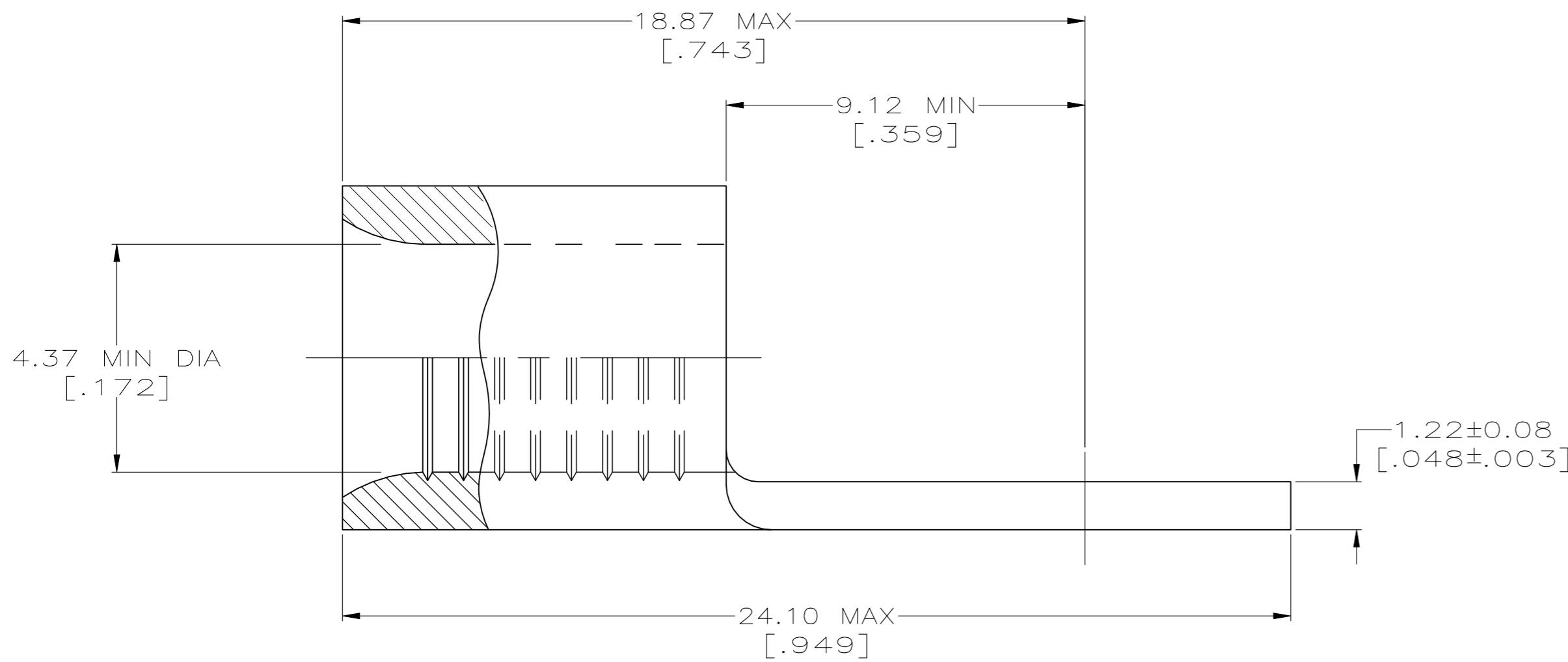

1000	LOOSE PIECE, BOX	2-31807-3
1000	ON TAPE	2-31807-2
----	LOOSE PIECE	31807
QTY	PACKAGING TYPE	PART NO.

AMP INCORPORATED CUSTOMER SERVICE SYSTEMS		MAX RECOMMENDED OPERATING TEMPERATURE: 170°C MAX
FOR ADDITIONAL PRODUCT INFORMATION OR COPIES OF DRAWINGS AND TECHNICAL DOCUMENTS	PRODUCT INFORMATION CENTER 1-800-522-6752	VOLTAGE RATING: N/A
FOR APPLICATION	TOOLING ASSISTANCE CENTER	CIRCULAR MIL AREA: 6.64-10.5mm² [13,100-20,800] SOLID OR STRANDED
TOOLING INFORMATION	1-800-722-1111	
FOR ORDER ENTRY	1-800-526-5142	

THIS DRAWING IS A CONTROLLED DOCUMENT.	
DIMENSIONS: MM [INCHES]	TOLERANCES UNLESS OTHERWISE SPECIFIED:
	0 PLC ± -
	1 PLC ± -
	2 PLC ± -
	3 PLC ± -
	4 PLC ± -
	ANGLES ± -
MATERIAL	FINISH
2	3

DWN TA BRINKMAN 3-24-93	TE Connectivity			
CHK DA PATTERSON 3-24-93				
APVD JL MECKLEY 3-24-93	NAME TERMINAL, RING TONGUE, SOLISTRAND			
PRODUCT SPEC	SIZE A2	CAGE CODE 00779	DRAWING NO C-31807	RESTRICTED TO
APPLICATION SPEC	WEIGHT	SCALE 8:1	SHEET 1 of 1	REV J4
CUSTOMER DRAWING				