IDT[®] Tsi578 Hardware Manual

April 4, 2016

Contents

1. Signals and Package	9
1.1 Pinlist	9
1.2 Signals	10
1.3 Package Characteristics	24
1.4 Thermal Characteristics	26
2. Electrical Characteristics	29
2.1 Absolute Maximum Ratings	29
2.2 Recommended Operating Conditions	30
2.3 Power	31
2.4 Electrical Characteristics	34
3. Layout Guidelines	41
3.1 Overview	41
3.2 Impedance Requirements	41
3.3 Tracking Topologies	42
3.4 Power Distribution	55
3.5 Decoupling Requirements	57
3.6 Clocking and Reset	61
3.7 Modeling and Simulation	65
3.8 Testing and Debugging Considerations	66
3.9 Reflow Profile	69
A. Clocking	71
A.1 Line Rate Support	71
A.2 P_CLK Programming	75
B. Ordering Information	87
B.1 Ordering Information	87

About this Document

This section discusses general document information about the Tsi578. The following topics are described:

- “Scope” on page 5
 - “Document Conventions” on page 5
 - “Revision History” on page 6
-

Scope

The *Tsi578 Hardware Manual* discusses electrical, physical, and board layout information for the Tsi578. It is intended for hardware engineers who are designing system interconnect applications with these devices.

Document Conventions

This document uses a variety of conventions to establish consistency and to help you quickly locate information of interest. These conventions are briefly discussed in the following sections.

Non-differential Signal Notation

Non-differential signals are either active-low or active-high. An active-low signal has an active state of logic 0 (or the lower voltage level), and is denoted by a lowercase “b”. An active-high signal has an active state of logic 1 (or the higher voltage level), and is not denoted by a special character. The following table illustrates the non-differential signal naming convention.

State	Single-line signal	Multi-line signal
Active low	NAME_b	NAME _n [3]
Active high	NAME	NAME[3]

Differential Signal Notation

Differential signals consist of pairs of complement positive and negative signals that are measured at the same time to determine a signal's active or inactive state (they are denoted by “_p” and “_n”, respectively). The following table illustrates the differential signal naming convention.

State	Single-line signal	Multi-line signal
Inactive	NAME_p = 0 NAME_n = 1	NAME_p[3] = 0 NAME_n[3] = 1
Active	NAME_p = 1 NAME_n = 0	NAME_p[3] is 1 NAME_n[3] is 0

Symbols



This symbol indicates a basic design concept or information considered helpful.



This symbol indicates important configuration information or suggestions.



This symbol indicates procedures or operating levels that may result in misuse or damage to the device.

Revision History

April 4, 2016

- Updated the package diagram in [Figure 2](#)
- Added GCLH, GCLV, GILH, and GILV part numbers to “[Ordering Information](#)” on [page 87](#)

May 18, 2012

- Updated the first paragraph in “[Power Sequencing](#)” on [page 33](#)
- Updated the caution above [Figure 2](#)

November 18, 2010

- Added a note to [Table 13](#)

July 2009

This is the production version of the *Serial RapidIO Switch*. The document has been updated with IDT formatting. There have been no technical changes.

May 2009

- Updated “[Power](#)” on [page 31](#)

November 2008

- The SP_IO_SPEED default value was updated in [Table 3 on page 13](#)
- The Moisture Sensitivity was improved from four to three in “[Package Characteristics](#)” on [page 24](#)

July 2008

- Updated “[Recommended Operating Conditions](#)” on [page 30](#)
- Updated “[Power](#)” on [page 31](#)

April 2008

- Information on “[Register Requirements Using 125 MHz S_CLK for a 3.125 Gbps Link Rate](#)” on [page 72](#) was added to “[Clocking](#)” on [page 71](#) and the supporting information was added to “[EEPROM Scripts](#).”

November 2007

- Information on “[P_CLK Programming](#)” on [page 75](#) was added to “[Clocking](#)” on [page 71](#).
- General clarification in “[Signals and Package](#)” on [page 9](#), including:
 - Any unused signal that is designated a No Connect (N/C) must be left unconnected
 - The I2C_SCLK signal description was updated
 - The BCE signal description was updated

1. Signals and Package

This chapter describes the packaging (mechanical) features for the Tsi578. It includes the following information:

- “Pinlist” on page 9
- “Signals” on page 10
- “Package Characteristics” on page 24
- “Thermal Characteristics” on page 26

1.1 Pinlist

The pinlist and ballmap information for the Tsi578 are available by visiting www.idt.com. For more information, see the following documents:

- *Tsi578 Pinlist*
- *Tsi578 Ballmap*

1.2 Signals

Figure 1: Signal Groupings

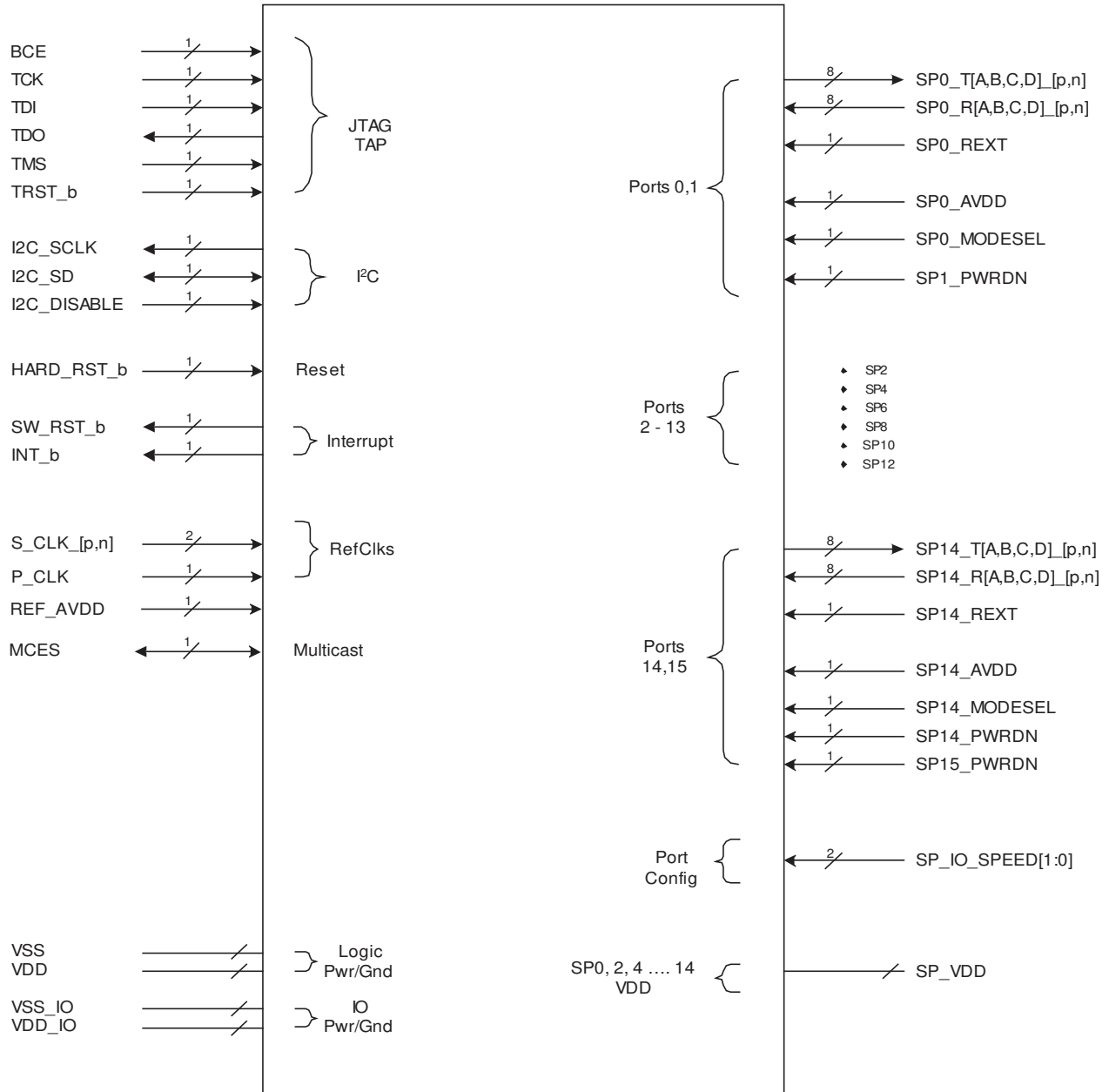

1.2.1 Conventions

The following conventions are used in the signal description table:

- Signals with the suffix “_p” are the positive half of a differential pair.
- Signals with the suffix “_n” are the negative half of a differential pair.
- Signals with the suffix “_b” are active low.

Signals are classified according to the types defined in [Table 1](#).

Table 1: Signal Types

Pin Type	Definition
I	Input
O	Output
I/O	Input/Output
OD	Open Drain
SRIO	Differential driver/receiver defined by <i>RapidIO Interconnect Specification (Revision 1.3)</i>
PU	Pulled Up internal to the Tsi578
PD	Pulled Down internal to the Tsi578
LVTTTL	CMOS I/O with LVTTTL thresholds
Hyst	Hysteresis
Core Power	Core supply
Core Ground	Ground for core logic
I/O Power	I/O supply
N/C	No connect These signals must be left unconnected.

1.2.2 Endian Ordering

This document follows the bit-numbering convention adopted by *RapidIO Interconnect Specification (Revision 1.3)*, where [0:7] is used to represent an 8 bit bus with bit 0 as the most-significant bit.

1.2.3 Port Numbering

The following table shows the mapping between port numbers and the physical ports. These port numbers are used within the destination ID lookup tables for ingress RapidIO ports and in numerous register configuration fields.

Table 2: Port Numbering

Port Number	RapidIO Port	Mode
0	Serial Port 0 (SP0)	1x or 4x
1	Serial Port 1 (SP1)	1x
2	Serial Port 2 (SP2)	1x or 4x
3	Serial Port 3 (SP3)	1x
4	Serial Port 4 (SP4)	1x or 4x
5	Serial Port 5 (SP5)	1x
6	Serial Port 6 (SP6)	1x or 4x
7	Serial Port 7 (SP7)	1x
8	Serial Port 8 (SP8)	1x or 4x
9	Serial Port 9 (SP9)	1x
10	Serial Port 10 (SP10)	1x or 4x
11	Serial Port 11 (SP11)	1x
12	Serial Port 12 (SP12)	1x or 4x
13	Serial Port 13 (SP13)	1x
14	Serial Port 14 (SP14)	1x or 4x
15	Serial Port 15 (SP15)	1x

1.2.4 Signal Grouping

The following table lists the signals by group and their recommended termination.

Table 3: Signal Descriptions and Recommended Termination

Pin Name	Type	Description	Recommended Termination ^a
PORT n = 1x/4x Mode Serial RapidIO PORT (n+1) = 1x Mode Serial RapidIO n = 0, 2, 4, 6, 8, 10, 12, 14			
Serial Port Transmit			
SP{n}_TA_p	O, SRIO	Port n Lane A Differential Non-inverting Transmit Data output (4x mode) Port n Lane A Differential Non-inverting Transmit Data output (1x mode)	No termination required.
SP{n}_TA_n	O, SRIO	Port n Lane A Differential Inverting Transmit Data output (4x mode) Port n Lane A Differential Inverting Transmit Data output (1x mode)	No termination required.
SP{n}_TB_p	O, SRIO	Port n Lane B Differential Non-inverting Transmit Data output (4x mode) Port n+1 Lane B Differential Non-inverting Transmit Data output (1x mode)	No termination required.
SP{n}_TB_n	O, SRIO	Port n Lane B Differential Inverting Transmit Data output (4x mode) Port n+1 Lane B Differential Inverting Transmit Data output (1x mode)	No termination required.
SP{n}_TC_p	O, SRIO	Port n Lane C Differential Non-inverting Transmit Data output (4x mode)	No termination required.
SP{n}_TC_n	O, SRIO	Port n Lane C Differential Inverting Transmit Data output (4x mode)	No termination required.
SP{n}_TD_p	O, SRIO	Port n Lane D Differential Non-inverting Transmit Data output (4x mode)	No termination required.
SP{n}_TD_n	O, SRIO	Port n Lane D Differential Inverting Transmit Data output (4x mode)	No termination required.

Table 3: Signal Descriptions and Recommended Termination

Pin Name	Type	Description	Recommended Termination ^a
Serial Port Receive			
SP{n}_RA_p	I, SRIO	Port n Lane A Differential Non-inverting Receive Data input (4x mode) Port n Lane A Differential Non-inverting Receive Data input (1x mode)	DC blocking capacitor of 0.1uF in series
SP{n}_RA_n	I, SRIO	Port n Lane A Differential Inverting Receive Data input (4x mode) Port n Lane A Differential Inverting Receive Data input (1x mode)	DC blocking capacitor of 0.1uF in series
SP{n}_RB_p	I, SRIO	Port n Lane B Differential Non-inverting Receive Data input (4x mode) Port n+1 Lane B Differential Non-inverting Receive Data input (1x mode)	DC blocking capacitor of 0.1uF in series
SP{n}_RB_n	I, SRIO	Port n Lane B Differential Inverting Receive Data input (4x mode) Port n+1 Lane B Differential Inverting Receive Data input (1x mode)	DC blocking capacitor of 0.1uF in series
SP{n}_RC_p	I, SRIO	Port n Lane C Differential Non-inverting Receive Data input (4x mode)	DC blocking capacitor of 0.1uF in series
SP{n}_RC_n	I, SRIO	Port n Lane C Differential Inverting Receive Data input (4x mode)	DC blocking capacitor of 0.1uF in series
SP{n}_RD_p	I, SRIO	Port n Lane D Differential Non-inverting Receive Data input (4x mode)	DC blocking capacitor of 0.1uF in series
SP{n}_RD_n	I, SRIO	Port n Lane D Differential Inverting Receive Data input (4x mode)	DC blocking capacitor of 0.1uF in series

Table 3: Signal Descriptions and Recommended Termination

Pin Name	Type	Description	Recommended Termination ^a
Serial Port Configuration			
SP{n}_REXT	Analog	Used to connect a resistor to VSS to provide a reference current for the driver and equalization circuits.	Must be connected to VSS with a 191-ohm (1%) resistor.
SP{n}_MODESEL	I/O, LVTTTL, PD	<p>Selects the serial port operating mode for ports n and n+1</p> <p>0 = Port n operating in 4x mode (Port n+1 not available)</p> <p>1 = Ports n and n+1 operating in 1x mode</p> <p>Note: The output capability of this pin is used only in test mode.</p> <p>Must remain stable for 10 P_CLK cycles after HW_RST_b is de-asserted in order to be sampled correctly.</p> <p>This signal is ignored after reset.</p>	<p>Pin must be tied off according to the required configuration. Either a 10K pull up to VDD_IO or a 10K pull-down to VSS_IO.</p> <p>Internal pull-down may be used for logic 0.</p>
SP{n}_PWRDN	I/O, LVTTTL, PU	<p>Port n Transmit and Receive Power Down control</p> <p>This signal controls the state of Port n <i>and</i> Port n+1</p> <p>The PWRDN controls the state of all four lanes (A/B/C/D) of SERDES Macro.</p> <p>0 = Port n Powered Up. Port n+1 controlled by SP{n+1}_PWRDN.</p> <p>1 = Port n Powered Down. Port n+1 Powered Down.</p> <p>Override SP{n}_PWRDN using PWDN_x1 field in "SRIO MAC x Clock Selection Register" in the <i>Tsi578 User Manual</i>.</p> <p>Output capability of this pin is only used in test mode.</p> <p>Must remain stable for 10 P_CLK cycles after HW_RST_B is de-asserted in order to be sampled correctly.</p> <p>This signal is ignored after reset.</p>	<p>Pin must be tied off according to the required configuration. Either a 10K pull up to VDD_IO or a 10K pull-down to VSS_IO.</p> <p>Internal pull-up may be used for logic 1.</p>

Table 3: Signal Descriptions and Recommended Termination

Pin Name	Type	Description	Recommended Termination ^a
SP{n+1}_PWRDN	I/O, LVTTTL, PU	<p>Port n+1 Transmit and Receive Power Down control</p> <p>This signal controls the state of Port n+1. Note that Port n+1 is never used when 4x mode is selected for a Serial Rapid IO MAC, and it must be powered down.</p> <p>0 = Port n+1 Powered Up 1 = Port n+1 Powered Down</p> <p>Override SP{n+1}_PWRDN using PWDN_x4 field SRIO MAC x Clock Selection Register.</p> <p>Output capability of this pin is only used in test mode.</p> <p>Must remain stable for 10 P_CLK cycles after HW_RST_B is de-asserted in order to be sampled correctly.</p> <p>This signal is ignored after reset.</p>	<p>Pin must be tied off according to the required configuration. Either a 10K pull up to VDD_IO or a 10K pull-down to VSS_IO.</p> <p>Internal pull-up may be used for logic 1.</p>

Table 3: Signal Descriptions and Recommended Termination

Pin Name	Type	Description	Recommended Termination ^a
Serial Port Speed Select			
SP_IO_SPEED[1]	I/O, LVTTTL, PU	<p>Serial Port Transmit and Receive operating frequency select, bit 1. When combined with SP_IO_SPEED[0], this pin selects the default serial port frequency for all ports.</p> <p>00 = 1.25 Gbit/s 01 = 2.5 Gbit/s 10 = 3.125 Gbit/s (default) 11 = Illegal</p> <p>Selects the speed at which the ports operates when reset is removed. This could be at either HARD_RST_b being de-asserted or by the completion of a self-reset.</p> <p>These signals must remain stable for 10 P_CLK cycles after HW_RST_b is de-asserted in order to be sampled correctly.</p> <p>These signals are ignored after reset and software is able to over-ride the port frequency setting in the SRIO MAC x Digital Loopback and Clock Selection register.</p> <p>The SP_IO_SPEED[1:0] setting is equal to the IO_SPEED field in SRIO MAC x Clock Selection Register.</p> <p>Output capability of this pin is only used in test mode.</p>	<p>Pin must be tied off according to the required configuration. Either a 10K pull-up to VDD_IO or a 10K pull-down to VSS_IO.</p> <p>Internal pull-down may be used for logic 0.</p>
SP_IO_SPEED[0]	I/O, LVTTTL, PD	See SP_IO_SPEED[1]	<p>Pin must be tied off according to the required configuration. Either a 10K pull-up to VDD_IO or a 10K pull-down to VSS_IO.</p> <p>Internal pull-up may be used for logic 1.</p>

Table 3: Signal Descriptions and Recommended Termination

Pin Name	Type	Description	Recommended Termination ^a
Serial Port Lane Ordering Select			
SP_RX_SWAP	I, LVTTTL, PD	<p>Configures the order of 4x receive lanes on serial ports [0,2,4,6,...,14].</p> <p>0 = A, B, C, D</p> <p>1 = D, C, B, A</p> <p>This signal is ignored in 1X mode.</p> <p>Must remain stable for 10 P_CLK cycles after HARD_RST_b is de-asserted in order to be sampled correctly.</p> <p>This signal is ignored after reset.</p> <p>Note: Ports that require the use of lane swapping for ease of routing will only function as 4x mode ports. The re-configuration of a swapped port to dual 1x mode operation results in the inability to connect to a 1x mode link partner.</p>	<p>No termination required.</p> <p>Internal pull-down can be used for logic 0. Pull up to VDD_IO through 10K if external pull-up is desired.</p> <p>Pull down to VSS_IO through a 10K resistor if an external pull-down is desired.</p>
SP_TX_SWAP	I, LVTTTL, PD	<p>Configures the order of 4x transmit lanes on serial ports [0,2,4,6,...,14].</p> <p>0 = A, B, C, D</p> <p>1 = D, C, B, A</p> <p>Must remain stable for 10 P_CLK cycles after HARD_RST_b is de-asserted in order to be sampled correctly.</p> <p>This signal is ignored after reset.</p> <p>Note: Ports that require the use of lane swapping for ease of routing only function as 4x mode ports. The re-configuration of a swapped port to dual 1x mode operation results in the inability to connect to a 1x mode link partner.</p>	<p>No termination required.</p> <p>Internal pull-down can be used for logic 0. Pull up to VDD_IO through 10K if external pull-up is desired.</p> <p>Pull down to VSS_IO through 10K resistor if an external pull-down is desired.</p>
Clock and Reset			
P_CLK	I, LVTTTL	<p>This clock is used for the register bus clock.</p> <p>The nominal frequency of this input clock is 100 MHz. For more information on programming the P_CLK operating frequency, refer to “P_CLK Programming”.</p>	No termination required.

Table 3: Signal Descriptions and Recommended Termination

Pin Name	Type	Description	Recommended Termination ^a
S_CLK_p	I, CML	Differential non-inverting reference clock. The clock is used for following purposes: SERDES reference clock, serial port system clock, ISF clock and test clock. The maximum frequency of this input clock is 156.25 MHz. The clock frequency is defined in “ Reference Clock, S_CLK_p/n ”. For more information on the S_CLK operating frequency, refer to “ Line Rate Support ”.	AC coupling capacitor of 0.1uF required.
S_CLK_n	I, CML	Differential inverting reference clock. The clock is used for following purposes: SerDes reference clock, serial port system clock, ISF clock and test clock. The maximum frequency of this input clock is 156.25 MHz. The clock frequency is defined in “ Reference Clock, S_CLK_p/n ”. For more information on the S_CLK operating frequency, refer to “ Line Rate Support ”.	AC coupling capacitor of 0.1uF required.
HARD_RST_b	I LVTTTL, Hyst, PU	Schmidt-triggered hard reset. Asynchronous active low reset for the entire device. The Tsi578 does not contain a voltage detector to generate internal reset.	Connect to a power-up reset source. Refer to “ Reset Requirements ”
Interrupts			
INT_b	O, OD, LVTTTL, 2mA	Interrupt signal (open drain output)	External pull-up required. Pull up to VDD_IO through a 10K resistor.

Table 3: Signal Descriptions and Recommended Termination

Pin Name	Type	Description	Recommended Termination ^a
SW_RST_b	O, OD, LVTTTL, 2mA	Software reset (open drain output): This signal is asserted when a RapidIO port receives a valid reset request on a RapidIO link. If self-reset is not selected, this pin remains asserted until the reset request is cleared from the status registers. If self-reset is selected, this pin remains asserted until the self reset is complete. If the Tsi578 is reset from the HARD_RST_b pin, this pin is de-asserted and remains de-asserted after HARD_RST_b is released. For more information, refer to “Resets” in the Tsi578 User’s Manual.	External pull-up required. Pull up to VDD_IO through a 10K resistor.
Multicast			
MCES	I/O, LVTTTL, PD	Multicast Event Symbol pin. As an input, an edge (rising or falling) will trigger a Multicast Event Control Symbol will be sent to all ports; As an output, this pin will toggle its value every time an Multicast Event Control Symbol is received by any port which is enabled for Multicast even control symbols. Must remain stable for 10 P_CLK cycles <i>before and after</i> a transition.	No termination required. This pin must not be driven by an external source until all power supply rails are stable.
I²C			
I2C_SCLK	I/O, OD, LVTTTL, PU 8mA	I ² C input/output clock, up to 100 kHz. If an EEPROM is present on the I ² C bus, this clock signal must be connected to the clock input of the serial EEPROM on the I ² C bus. If an EEPROM is not present, the recommended terminations should be used.	No termination required. Internal pull-up may be used for logic 1. Pull up to VDD_IO through a minimum 470 ohms resistor if higher edge rate is required.
I2C_SD	I/O, OD, LVTTTL, PU 8mA	I ² C input and output data bus (bidirectional open drain)	No termination required. Internal pull-up may be used for logic 1. Pull up to VDD_IO through a minimum 470 ohms resistor if higher edge rate required.

Table 3: Signal Descriptions and Recommended Termination

Pin Name	Type	Description	Recommended Termination ^a
I2C_DISABLE	I, LVTTTL, PD	<p>Disable I²C register loading after reset. When asserted, the Tsi578 does not attempt to load register values from I²C.</p> <p>0 = Enable I²C register loading 1 = Disable I²C register loading</p> <p>Must remain stable for 10 P_CLK cycles after HARD_RST_b is de-asserted in order to be sampled correctly.</p> <p>Note: This signal does not control the slave accessibility of the interface.</p> <p>This signal is ignored after reset.</p>	<p>No termination required.</p> <p>Pull up to VDD_IO through a 10K resistor if I²C loading is not required.</p>
I2C_MA	I, CMOS, PU	<p>I²C Multibyte Address.</p> <p>When driven high, I²C module will expect multi-byte peripheral addressing; otherwise, when driven low, single-byte peripheral address is assumed.</p> <p>Must remain stable for 10 P_CLK cycles after HW_RST_b is de-asserted in order to be sampled correctly.</p> <p>This signal is ignored after reset.</p>	<p>No termination required.</p> <p>Internal pull-up may be used for logic 1.</p> <p>Pull up to VDD_IO through 10K resistor if an external pull-up is desired. Pull down to VSS_IO to change the logic state.</p>
I2C_SA[1,0]	I, CMOS, PU	<p>I²C Slave Address pins.</p> <p>The values on these two pins represent the values for the lower 2 bits of the 7-bit address of Tsi578 when acting as an I²C slave (see I²C Slave Configuration register).</p> <p>The values at these pins can be overridden by software after reset.</p>	<p>No termination required.</p> <p>Internal pull-up may be used for logic 1.</p> <p>Pull up to VDD_IO through 10K resistor if an external pull-up is desired. Pull down to VSS_IO to change the logic state.</p>

Table 3: Signal Descriptions and Recommended Termination

Pin Name	Type	Description	Recommended Termination ^a
I2C_SEL	I, CMOS, PU	<p>I²C Pin Select. Together with the I2C_SA[1,0] pins, Tsi578 will determine the lower 2 bits of the 7-bit address of the EEPROM address it boots from.</p> <p>When asserted, the I2C_SA[1,0] values will also be used as the lower 2 bits of the EEPROM address.</p> <p>When de-asserted, the I2C_SA[1,0] pins will be ignored and the lower 2 bits of the EEPROM address are default to 00.</p> <p>The values of the lower 2 bits of the EEPROM address can be over-ridden by software after reset.</p>	<p>No termination required. Internal pull-up may be used for logic 1.</p> <p>Pull up to VDD_IO through 10K resistor if an external pull-up is desired. Pull down to VSS_IO to change the logic state.</p>
JTAG TAP Controller			
TCK	I, LVTTTL, PD	IEEE 1149.1 Test Access Port Clock input	Pull up to VDD_IO through 10K resistor if not used.
TDI	I, LVTTTL, PU	IEEE 1149.1 Test Access Port Serial Data Input	Pull up to VDD_IO through a 10K resistor if the signal is not used or a if higher edge rate is required.
TDO	O, LVTTTL, 2mA	IEEE 1149.1 Test Access Port Serial Data Output	<p>No connect if JTAG is not used.</p> <p>Pull up to VDD_IO through a 10K resistor if used.</p>
TMS	I, LVTTTL, PU	IEEE 1149.1 Test Access Port Test Mode Select	Pull up to VDD_IO through a 10K resistor if not used.
TRST_b	I, LVTTTL, PU	<p>IEEE 1149.1 Test Access Port TAP Reset Input</p> <p>This input must be asserted during the assertion of HARD_RST_b. Afterwards, it may be left in either state.</p> <p>Combine the HARD_RST_b and TRST_b signals with an AND gate and use the output to drive the TRST_b pin.</p>	Tie to VSS_IO through a 10K resistor if not used.

Table 3: Signal Descriptions and Recommended Termination

Pin Name	Type	Description	Recommended Termination ^a
BCE	I, LVTTTL, PU	Boundary Scan compatibility enabled pin. This input is used to aid 1149.6 testing. This signal also enables system level diagnostic capability using features built into the SerDes. For more information on this functionality, refer to the Serial RapidIO Signal Analyzer documentation. This signal must be tied to VDD_IO during normal operation of the device, and during JTAG accesses of the device registers	This signal should have the capability to be pulled-up or pulled-low. <ul style="list-style-type: none"> The default setting is to be pulled-up. Pulling the signal low enables the signal analyzer functionality on the SerDes A 10K resistor to VDD_IO should be used.
Power Supplies			
SP_AVDD	-	Port n and n+1: 3.3V supply for bias generator circuitry. This is required to be a low-noise supply.	Refer to ““Decoupling Requirements””
REF_AVDD	-	Analog 1.2V for Reference Clock (S_CLK_p/n). Clock distribution network power supply.	Refer to ““Decoupling Requirements””
Common Supply			
VDD_IO	-	Common 3.3V supply for LVTTTL I/O	Refer to ““Decoupling Requirements””
VSS	-	Common ground supply for digital logic	Refer to ““Decoupling Requirements””
VDD	-	Common 1.2V supply for digital logic	Refer to ““Decoupling Requirements””
SP_VDD	-	1.2V supply for CDR, Tx/Rx, and digital logic for all RapidIO ports	Refer to ““Decoupling Requirements””

a. Signals for unused serial ports do not require termination and can be left as N/Cs.

1.3 Package Characteristics

The Tsi578's package characteristics are summarized in the following table. The following figures show the top, side, and bottom views of the Tsi578 package.

Table 4: Package Characteristics

Feature	Description
Package Type	Flip-Chip Ball Grid Array (FCBGA)
Ball count	675-ball
Package Body Size	27 mm x 27 mm
JEDEC Specification	95-1 Section 14
Pitch	1.00 mm
Ball pad size	500 um
Soldermask opening	400 um
Moisture Sensitivity Level	3



The capacitors shown in [Figure 2](#) are not present on the Tsi578 package.

Figure 2: Package Diagram

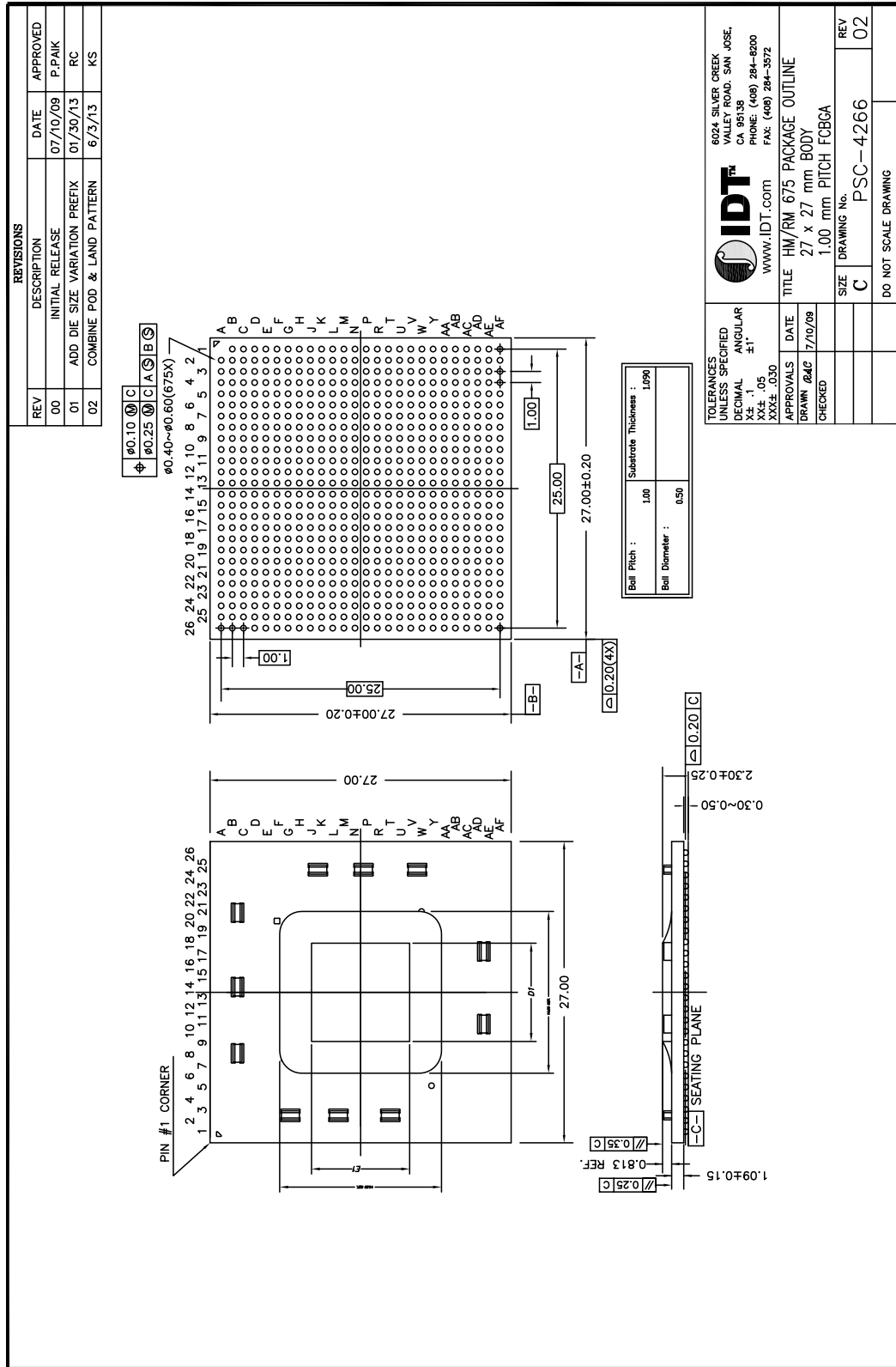

1.4 Thermal Characteristics

Heat generated by the packaged IC has to be removed from the package to ensure that the IC is maintained within its functional and maximum design temperature limits. If heat buildup becomes excessive, the IC temperature may exceed the temperature limits. A consequence of this is that the IC may fail to meet the performance specifications and the reliability objectives may be affected.

Failure mechanisms and failure rate of a device have an exponential dependence of the IC operating temperatures. Thus, the control of the package temperature, and by extension the Junction Temperature, is essential to ensure product reliability. The Tsi578 is specified safe for operation when the Junction Temperature is within the recommended limits.

Table 5 shows the simulated Theta j_b and Theta j_c thermal characteristics of the Tsi578 FCBGA package.

Table 5: Thermal Characteristics

Interface	Result
Theta j _b (junction to board)	11.7 °C/watt
Theta j _c (junction to case)	0.08 °C/watt

1.4.1 Junction-to-Ambient Thermal Characteristics (Theta j_a)

The following table shows the simulated Theta j_a thermal characteristic of the Tsi578 FCBGA package. The results in the table are based on a JEDEC Thermal Test Board configuration (JESD51-9) and do not factor in system level characteristics. As such, these values are for reference only.



The Theta j_a thermal resistance characteristics of a package depend on multiple system level variables.

Table 6: Simulated Junction to Ambient Characteristics

Package	Theta j _a at specified airflow (no Heat Sink)		
	0 m/s	1 m/s	2 m/s
Tsi578 FCBGA	14.6 C/watt	13.6 °C/watt	12.9 °C/watt

1.4.1.1 System-level Characteristics

In an application, the following system-level characteristics and environmental issues must be taken into account:

- Package mounting (vertical / horizontal)
- System airflow conditions (laminar / turbulent)
- Heat sink design and thermal characteristics (see “[Heatsink Requirement and Analysis](#)” on page 27)
- Heat sink attachment method (see “[Heatsink Requirement and Analysis](#)” on page 27)
- PWB size, layer count and conductor thickness
- Influence of the heat dissipating components assembled on the PWB (neighboring effects)

Example on Thermal Data Usage

Based on the Θ_{JA} data and specified conditions, the following formula can be used to derive the junction temperature (T_j) of the Tsi578 with a 0m/s airflow:

- $T_j = \Theta_{JA} * P + T_{amb}$.

Where: T_j is Junction Temperature, P is the Power consumption, T_{amb} is the Ambient Temperature

Assuming a power consumption (P) of 3.5 W and an ambient temperature (T_{amb}) of 70°C, the resulting junction temperature (T_j) would be 121.1°C.

1.4.2 Heatsink Requirement and Analysis

The Tsi578 is packaged in a Flip-Chip Ball Grid Array (FCBGA). With this package technology, the silicon die is exposed and serves as the interface between package and heatsink. Where a heatsink is required to maintain junction temperatures at or below specified maximum values, it is important that attachment techniques and thermal requirements be critically analyzed to ensure reliability of this interface. Factors to be considered include: surface preparations, selection of thermal interface materials, curing process, shock and vibration requirements, and thermal expansion coefficients, among others. Each design should be individually analyzed to ensure that a reliable thermal solution is achieved.



Both mechanical and adhesive techniques are available for heatsink attachment. IDT makes no recommendations as to the reliability or effectiveness of either approach. The designer must critically analyze heatsink requirements, selection criteria, and attachment techniques.

For heatsink attachment methods that induce a compressive load to the FCBGA package, the maximum force that can be applied to the package should be limited to 5 gm / BGA ball (provided that the board is supported to prevent any flexing or bowing). The maximum force for the Tsi578 package is 3.38 Kg.

2. Electrical Characteristics

This chapter provides the electrical characteristics for the Tsi578. It includes the following information:

- “Absolute Maximum Ratings” on page 29
- “Recommended Operating Conditions” on page 30
- “Power” on page 31

2.1 Absolute Maximum Ratings

Operating the device beyond the listed operating conditions is not recommended. Stressing the Tsi578 beyond the Absolute Maximum Rating can cause permanent damage.

Table 7 lists the absolute maximum ratings.

Table 7: Absolute Maximum Ratings

Symbol	Parameter	Min	Max	Unit
T_{storage}	Storage Temperature	-55	125	°C
$V_{\text{DD_IO}}$	3.3 V DC Supply Voltage	-0.5	4.6	V
SP_AVDD	3.3 V Analog Supply Voltage	-0.5	4.6	V
$V_{\text{DD}}, \text{SP_VDD}, \text{REF_AVDD}$	1.2 V DC Supply Voltage	-0.3	1.7	V
$V_{\text{I_SP}\{n\}\text{-R}\{A\text{-D}\}_{\{p,n\}}}$	SERDES Port Receiver Input Voltage	-0.3	3	V
$V_{\text{O_SP}\{n\}\text{-T}\{A\text{-D}\}_{\{p,n\}}}$	SERDES Port VM Transmitter Output Voltage	-0.3	3	V
SP_AVDD	Transient di/dt	-	0.0917	A/nS
SP_VDD	Transient di/dt	-	0.136	A/nS

Table 7: Absolute Maximum Ratings

Symbol	Parameter	Min	Max	Unit
V_{O_LVTTL}	LVTTTL Output or I/O Voltage	-0.5	$V_{DD_IO} + 0.5$	V
V_{ESD_HBM}	Maximum ESD Voltage Discharge Tolerance for Human Body Model (HBM). [Test Conditions per JEDEC standard - JESD22-A114-B]	-	2000	V
V_{ESD_CDM}	Maximum ESD Voltage Discharge Tolerance for Charged Device Model (CDM). Test Conditions per JEDEC standard - JESD22-C101-A	-	500	V

2.2 Recommended Operating Conditions

Table 8 lists the recommended operating conditions.



Continued exposure of IDT's devices to the maximum limits of the specified junction temperature could affect the device reliability. Subjecting the devices to temperatures beyond the maximum/minimum limits could result in a permanent failure of the device.

Table 8: Recommended Operating Conditions

Symbol	Parameter	Min	Max	Unit
T_j	Junction temperature	-40	125°	°C
V_{DD_IO}	3.3 V DC Supply Voltage	2.97	3.63	V
SP_AVDD	3.3 V Analog Supply Voltage	2.97	3.63	V
V_{DD,SP_VDD,REF_AVDD}	1.2 V DC Supply Voltage	1.14	1.29	V
I_{VDD_IO}	3.3 V IO Supply Current ^a	-	15	mA
I_{SP_VDD}	SerDes Digital Supply Current ^a	-	1060	mA
I_{SP_AVDD}	3.3 V SerDes Supply Current ^a	-	842	mA
I_{VDD}	1.2 V Core Supply Current ^a	-	2070	mA
I_{REF_AVDD}	1.2 V Ref Clock Supply Current	-	12.5	mA

Table 8: Recommended Operating Conditions

Symbol	Parameter	Min	Max	Unit
V_{ripple1}	Power Supply ripple for Voltage Supplies: SP_VDD, VDD and VDD_IO	-	100	mV _{pp}
V_{ripple2}	Power Supply ripple for Voltage Supplies: SP{n}_AVDD, REF_AVDD	-	50	mV _{pp}
I_{REXT}	External reference resistor current	-	10	uA

- a. The current values provided are maximum values and dependent on device configuration, such as port usage, traffic, etc.

2.3 Power

The following sections describe the Tsi578's power dissipation and power sequencing.

2.3.1 Power Dissipation

The Tsi578's power dissipation values are dependent on device configuration, such as line rate, port configuration, and traffic.

The following tables show the power in both 1x and 4x mode configurations in 125°C ambient temperature, typical process and voltage conditions.

1x Mode

Table 9: Tsi578 Power Dissipation in 1x Mode, 16 Links in Operation

Line Rate	1.25 GBaud	2.5 GBaud	3.125 GBaud
VDD_CORE	0.898	1.402	1.668
SP_VDD	0.795	0.737	0.898
SP_AVDD	1.372	1.538	1.749
VDD_IO	0.003	0.003	0.003
Power (W)	3.069	3.680	4.318
Secondary Port Power (W)	0.044	0.075	0.099
Primary Port Power (W)	0.297	0.342	0.398

Notes:

- Power is provided for typical process and voltage, and 25°C ambient temperature
- VDD_CORE supplies the ISF and other internal digital logic
- SP_VDD supplies the digital portion of the Serial RapidIO SerDes
- SP_AVDD supplies the analog portion of the Serial RapidIO SerDes
- VDD_IO supplies power for all non-Serial RapidIO I/O
- Power is modeled for link utilization of approximately 25%
- SerDes I/O drive parameters are set to default values in the SRIO MAC x SerDes Configuration Channel register (TX_BOOST) and the SRIO MAC x SerDes Configuration Global register (Tx_LVL)
- The primary port associated with each SerDes must be enabled before any secondary ports can be used

4x Mode**Table 10: Tsi578 Power Dissipation in 4x Mode, 4 Links in Operation**

Line Rate	1.25 GBaud	2.5 GBaud	3.125 GBaud
VDD_CORE	0.833	1.292	1.502
SP_VDD	0.784	0.845	1.063
SP_AVDD	1.381	1.733	2.007
VDD_IO	0.003	0.003	0.003
Power (W)	3.000	3.873	4.576
Port Power (W)	0.332	0.441	0.529

Table 10 Notes:

- Power is provided for typical process and voltage, and 25°C ambient temperature
- VDD_CORE supplies the ISF and other internal digital logic
- SP_VDD supplies the digital portion of the Serial RapidIO SerDes
- SP_AVDD supplies the analog portion of the Serial RapidIO SerDes
- VDD_IO supplies power for all non-Serial RapidIO I/O
- Power is modeled for link utilization of approximately 25%

- SerDes I/O drive parameters (TX_ATTEN, TX_BOOST) are set to default values in the SRIO MAC x SerDes Configuration Channel register.

2.3.2 Power Sequencing

Power-up option pins that are controlled by a logic device, in addition to all clocks, must not be driven until all power supply rails to the Tsi578 are stable. External devices also must not be permitted to sink current from, or source current to, the device because of the risk of triggering ESD protection or causing a latch-up condition.

The Tsi578 must have the supplies powered-up in the following order:

- VDD (1.2 V) must be powered up first
- SP_VDD (1.2 V) and REF_AVDD (1.2 V) should power up at approximately the same time as VDD
- Delays between the powering up of VDD, SP_VDD, and REF_AVDD are acceptable.
- No more than 50ms after VDD is at a valid level, VDD_IO (3.3 V) should be powered up to a valid level
- VDD_IO (3.3V) must not power up before VDD (1.2 V)
- SP_AVDD (3.3V) should power up at approximately the same time as VDD_IO
- Delays between powering up VDD_IO and SP_AVDD are acceptable
- SP_AVDD must not power up before SP_VDD



It is recommended that there is no more than 50ms between ramping of the 1.2 V and 3.3 V supplies. The power supply ramp rates must be kept between 10 V/s and 1×10^6 V/s to minimize power current spikes during power up.

If it is necessary to sequence the power supplies in a different order than that recommended above, the following precaution must be taken:

- Any power-up option pins must be current limited with 10 K ohms to VDD_IO or VSS_IO as required to set the desired logic level.

2.3.2.1 Power-down

Power down is the reverse sequence of power up:

- VDD_IO (3.3V) and SP_AVDD
- VDD (1.2V), SP_VDD and REF_AVDD power-down at the same time
- Or all rails falling simultaneously

2.4 Electrical Characteristics

This section describes the AC and DC signal characteristics for the Tsi578.

2.4.1 SerDes Receiver (SP{n}_RD_p/n)

Table 11 lists the electrical characteristics for the SerDes Receiver in the Tsi578.

Serial RapidIO signals may be presented to the receiver differential inputs while the switch is in an un-powered state only if a return current path (VSS) is present between the Tsi578 and the source of the signal. For example, this situation can occur if the Tsi578 is located on an AMC card that has been inserted into an active uTCA chassis and the slot power has been left in the off state.

Table 11: SerDes Receiver Electrical Characteristics

Symbol	Parameter	Min	Typ	Max	Unit	Notes
Z _{DI}	RX Differential Input impedance	90	100	110	Ohm	-
V _{DIFFI}	RX Differential Input Voltage	170	-	1600	mV	-
L _{CR}	RX Common Mode Return Loss	-	-	6	dB	Over a range 100MHz to 0.8* Baud Frequency
L _{DR}	RX Differential Return Loss	-	-	10	dB	Over a range 100MHz to 0.8* Baud Frequency
V _{LOS}	RX Loss of Input Differential Level	55	-	-	mV	Port Receiver Input level below which Low Signal input is detected
T _{RX_ch_skew}	RX Channel to Channel Skew Tolerance	-	-	24	ns	Between channels in a given x4 port @ 1.25/2.5Gb/s
		-	-	22	ns	Between channels in a given x4 port @ 3.125Gb/s
R _{TR} ,R _{TF}	RX Input Rise/Fall times	-	-	160	ps	Between 20% and 80% levels

2.4.2 SerDes Transmitter (SP{n}_TD_p/n)

Table 12 lists the electrical characteristics for the SerDes transmitter in the Tsi578.

Table 12: SerDes Transmitter Electrical Characteristics

Symbol	Parameter	Min	Typ	Max	Unit	Notes
Z_{SEO}	TX Single-Ended Output impedance	45	50	55	Ohm	-
Z_{DO}	TX Differential Output Impedance	90	100	110	Ohm	-
V_{SW}	TX Output Voltage Swing (Single-ended)	425		600	mVp -p	V_{SW} (in mV) = $Z_{SEO}/2 \times I_{nom} \times R_{ldr}/I_{nom}$, where R_{ldr}/I_{nom} is the I_{dr} to I_{nom} ratio
V_{DIFFO}	TX Differential Output Voltage Amplitude	-	$2 \times V_{SW}$		mVp -p	+/- 2%
V_{OL}	TX Output Low-level Voltage	-	1.2 - V_{SW}		V	-
V_{OH}	TX Output High-level Voltage	-	1.2		V	-
V_{TCM}	TX common-mode Voltage	-	1.2 - $V_{SW}/2$		V	-
L_{DR1}	TX Differential Return Loss	-	-	10	dB	Baud Frequency)/10 < Freq(f) < 625 MHz
L_{DR2}	TX Differential Return Loss	-	-	10 + $ 10 \log(f/625 \text{ MHz}) $	dB	625 MHz <= Freq(f) <= Baud Frequency
T_{TX_skew}	TX Differential signal skew	-	-	15	ps	Skew between _p and _n signals on a give Serial channel
T_{TR}, T_{TF}	TX Output Rise/Fall times	80	-	110	ps	Between 20% and 80% levels

2.4.3 Reference Clock, S_CLK_p/n

Table 13 lists the electrical characteristics for the differential SerDes Reference clock input (S_CLK_p/n) in the Tsi578.

The S_CLK differential signal may be presented to the reference clock input while the switch is in an un-powered state only if a return current path (VSS) is present between the Tsi578 and the source of the signal. For example, this situation can occur if the Tsi578 is located on an AMC card that has been inserted into an active uTCA chassis and the slot power has been left in the off state.

Table 13: Reference Clock (S_CLK_p/n) Electrical Characteristics

Symbol	Parameter	Min ^a	Typ	Max	Unit	Notes
V _{SW}	Input voltage swing	0.1	0.5	1	V	-
V _{DIFF}	Differential input voltage swing	$V_{DIFF} = V_{SW} * 2$			V	-
V _{CM}	Differential Input Common Mode Range ((S_CLK_p + S_CLK_n)/2)	175	-	2000	mV	The S_CLK_p/n must be AC coupled.
F _{in}	Input Clock Frequency	156.25	-	156.25	MHz	-
F _{S_CLK_P/N}	Ref Clock Frequency Stability	-100	-	+100	ppm	PPM with respect to 156.25 MHz.
F _{in_DC}	Ref Clock Duty Cycle	40	50	60	%	-
T _{skew}	Ref Clock Skew	-	-	0.32	ns	Between _p and _n inputs.
T _{R_SCLK} , T _{F_SCLK}	S_CLK_p/n Input Rise/Fall Time	-	-	1	ns	-
J _{CLK-REF}	Total Phase Jitter, rms	-	-	3	ps _{rms}	See below ^b
Z _{in}	Input Impedance	80	100	114	ohms	-

a. RMS jitter from phase noise:

{** notation means "to the power of"}

{dBc will be a negative value from the data sheet}

$$\text{RMSjitter ps(rms)} = [((10^{**(\text{dBc}/10)})^{**1/2}) * 2] / [2 * \pi * (\text{freq in hz})]$$

{For 312.5 MHz and a phase noise of -63dBc, the RMS jitter = 0.72pS}

Peak to Peak jitter from RMS:

$$\text{RJ(p-p)} = a * \text{RJ(rms)} \text{ where } a = 14.069 \text{ (a constant based on bit error rate for a given standard deviation)}$$

- b. Total Permissible Phase Jitter on the Reference Clock is 3 ps rms. This value is specified with assumption that the measurement is done with a 20 G Samples/s scope with more than 1 million samples taken. The zero-crossing times of each rising edges are recorded and an average Reference Clock is calculated. This average period may be subtracted from each sequential, instantaneous period to find the difference between each reference clock rising edge and the ideal placement to produce the Phase Jitter Sequence. The PSD of the phase jitter is calculated and integrated after being weighted with the transfer function shown in [Figure 3](#). The square root of the resulting integral is the rms Total Phase Jitter.

Figure 3: Weighing function for RMS Phase Jitter Calculation

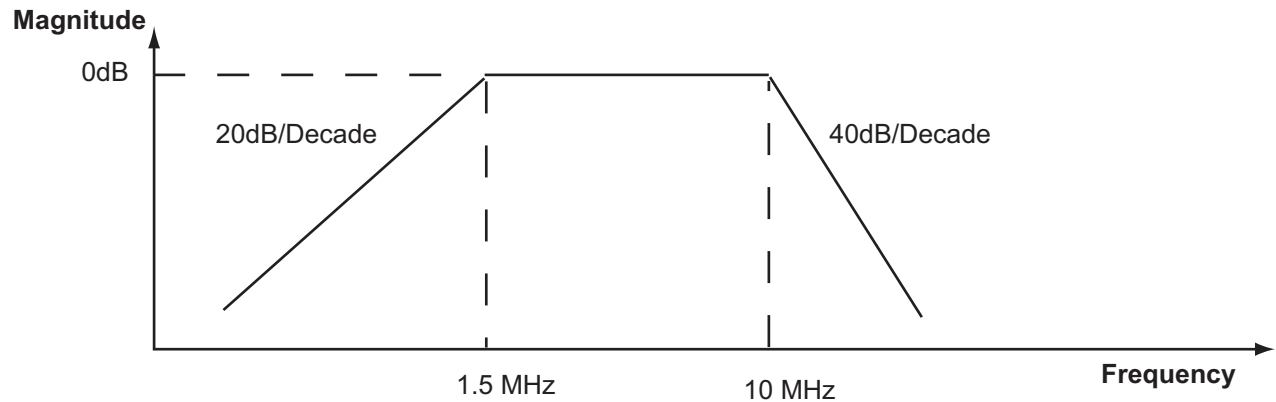

2.4.4 LVTTTL I/O and Open Drain Signals

Table 14 lists the electrical characteristics for the 3.3 V digital LVTTTL Interface pins on the Tsi578.

Table 14: LVTTTL I/O and Open Drain Electrical Characteristics

Symbol	Parameter	Min	Typ	Max	Unit	Notes
V_{IL}	LVTTTL Input Low Voltage	-	-	0.8	V	All inputs and I/Os of LVTTTL type
V_{IH}	LVTTTL Input High Voltage	2.0	-	-	V	All inputs and I/Os of LVTTTL type
I_{IL}	LVTTTL Input Low Current	-	-	10	μ A	All non-PU inputs and I/Os of LVTTTL type
I_{IH}	LVTTTL Input High Current	-	-	-10	μ A	All non-PD inputs and I/Os of LVTTTL type
I_{OZL_PU}, I_{IL_PU}	LVTTTL Input Low/ Output Tristate Current	5	-	100	μ A	All PU inputs and I/Os of LVTTTL type for voltages from 0 to V_{DD_IO} on the pin.
I_{OZH_PD}, I_{IH_PD}	LVTTTL Input High/ Output Tristate Current	-5	-	-100	μ A	All PD inputs and I/Os of LVTTTL type for voltages from 0 to V_{DD_IO} on the pin.
V_{OL}	LVTTTL Output Low Voltage	-	-	0.4	V	$I_{OL}=2\text{mA}$ for INT_b, SW_RST_b, and TDO pins $I_{OL}=8\text{mA}$ for I2C_CLK and I2C_SD pins
V_{OH}	LVTTTL Output High Voltage	$V_{DD_IO} - 0.5$	-	-	V	$I_{OH}=2\text{mA}$ for INT_b, SW_RST_b, and TDO pins

Table 14: LVTTTL I/O and Open Drain Electrical Characteristics

Symbol	Parameter	Min	Typ	Max	Unit	Notes
V _{OVERSHOOT}	Dynamic Overshoot	-	-	0.9	V	0.9V Max with a maximum energy of 0.75 V-ns
V _{UNDERSHOOT}	Dynamic Undershoot	-	-	-0.9	V	-0.9V Max with a maximum energy of 0.75 V-ns
V _{Hyst}	LVTTTL Input Hysteresis Voltage	-	200	-	mV	All Hyst inputs and I/Os of LVTTTL type
C _{Pad}	LVTTTL Pad Capacitance	-	-	10	pF	All pads of LVTTTL type
T _{cfgpS}	Configuration Pin Setup Time	100	-	-	ns	For all Configuration pins (except SP{n}_MODESEL with respect to HARD_RST_b rising edge
T _{cfgpH}	Configuration Pin Hold Time	100	-	-	ns	For all Configuration pins (except SP{n}_MODESEL) with respect to HARD_RST_b rising edge
T _{sp_modeSelS}	SP{n}_MODESEL Setup Time	5	-	-	ns	with respect to rising edge of P_CLK. SP{n}_MODESEL pins are sampled on every rising edge of P_CLK.
T _{sp_modeSelH}	SP{n}_MODESEL Hold Time	5	-	-	ns	with respect to rising edge of P_CLK. SP{n}_MODESEL pins are sampled on every rising edge of P_CLK.
T _{ISOV1}	INT_b/SW_RST_b Output Valid Delay from rising edge of P_CLK	-	-	15	ns	Measured between 50% points on both signals. Output Valid delay is guaranteed by design.
T _{ISOF1}	INT_b/SW_RST_b Output Float Delay from rising edge of P_CLK	-	-	15	ns	A float condition occurs when the output current becomes less than I _{LO} , where I _{LO} is 2 x I _{OZ} . Float delay guaranteed by design.
F _{in_P_CLK}	Input Clock Frequency	100	-	100	MHz	-
F _{in_STAB}	P_CLK Input Clock Frequency Stability	-100	-	+100	ppm	-
F _{in_PCLK_DC}	P_CLK Input Clock Duty Cycle	40	50	60	%	-
J _{PCLK}	P_CLK Input Jitter	-	-	300	ps _{pp}	-

Table 14: LVTTTL I/O and Open Drain Electrical Characteristics

Symbol	Parameter	Min	Typ	Max	Unit	Notes
T_{R_PCLK} , T_{F_PCLK}	P_CLK Input Rise/Fall Time	-	-	2.5	ns	-
f_{MCES}	MCES pin frequency	-	-	1	MHz	both as input and output
R pull-up	Resistor pull-up	82K	-	260K	ohms	@Vil=0.8V
R pull-down	Resistor pull-down	28K	-	54K	ohms	@Vih=2.0V

2.4.5 I²C Interface

Table 15 lists the AC specifications for Tsi578's I²C Interface. The I2C interfaces includes balls: I2C_SCLK, I2C_SD, I2C_DISABLE, I2C_MA, I2C_SEL, I2C_SA[1:0] and I2C_SEL.

Table 15: AC Specifications for I²C Interface

Symbol	Parameter	Min	Max	Units	Notes
F_{SCL}	I2C_SD/I2C_SCLK Clock Frequency	0	100	kHz	-
T_{BUF}	Bus Free Time Between STOP and START Condition	4.7	-	μ s	1
T_{LOW}	I2C_SD/I2C_SCLK Clock Low Time	4.7	-	μ s	1
T_{HIGH}	I2C_SD/I2C_SCLK Clock High Time	4	-	μ s	1
T_{HDSTA}	Hold Time (repeated) START condition	4	-	μ s	1,2
T_{SUSTA}	Setup Time for a Repeated START condition	4.7	-	μ s	1
T_{HDDAT}	Data Hold Time	0	3.45	μ s	1
T_{SUDAT}	Data Setup Time	250	-	ns	1
T_{SR}	Rise Time for I2C_xxx (all I2C signals)	-	1000	ns	1
T_{SF}	Fall Time for I2C_xxx (all I2C signals)	-	300	ns	1
T_{SUSTOP}	Setup Time for STOP Condition	4	-	μ s	1

Notes:

1. See Figure 4, I²C Interface Signal Timings.
2. After this period, the first clock pulse is generated.

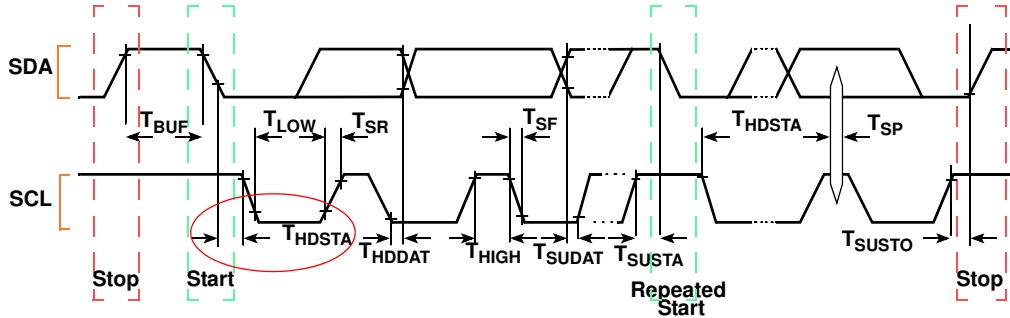
Figure 4: I²C Interface Signal Timings

2.4.6 Boundary Scan Test Interface Timing

Table 16 lists the test signal timings for Tsi578.

Table 16: Boundary Scan Test Signal Timings

Symbol	Parameter	Min	Max	Units	Notes
T_{BSF}	TCK Frequency	0	25	MHz	-
T_{BSCH}	TCK High Time	50	-	ns	<ul style="list-style-type: none"> Measured at 1.5V Note test
T_{BSCL}	TCK Low Time	50	-	ns	<ul style="list-style-type: none"> Measured at 1.5V Note test
T_{BSCR}	TCK Rise Time	-	25	ns	<ul style="list-style-type: none"> 0.8V to 2.0V Note test
T_{BSCF}	TCK Fall Time	-	25	ns	<ul style="list-style-type: none"> 2.0V to 0.8V Note test
T_{BSIS1}	Input Setup to TCK	10	-	ns	-
T_{BSIH1}	Input Hold from TCK	10	-	ns	-
T_{BSOV1}	TDO Output Valid Delay from falling edge of TCK ^a	-	15	ns	-
T_{OF1}	TDO Output Float Delay from falling edge of TCK	-	15	ns	-
$T_{BSTRST1}$	TRST_B release before HARD_RST_b release	-	10	ns	TRST_b must become asserted while HARD_RST_b is asserted during device power-up
$T_{BSTRST2}$	TRST_B release before TMS or TDI activity	1	-	ns	-

a. Outputs precharged to VDD.

3. Layout Guidelines

This chapter describes the layout guidelines for the Tsi578. It includes the following information:

- “Impedance Requirements” on page 41
- “Tracking Topologies” on page 42
- “Power Distribution” on page 55
- “Decoupling Requirements” on page 57
- “Clocking and Reset” on page 61
- “Modeling and Simulation” on page 65
- “Testing and Debugging Considerations” on page 66
- “Reflow Profile” on page 69

3.1 Overview

The successful implementation of a Tsi578 in a board design is dependent on properly routing the Serial RapidIO signals and maintaining good signal integrity with a resultant low bit error rate. The sections that follow contain information for the user on principals that will maximize the signal quality of the links.

Since every situation is different, IDT urges the designer to model and simulate their board layout and verify that the layout topologies chosen will provide the performance required of the product.

3.2 Impedance Requirements

The impedance requirement of the Serial RapidIO interface is 100 ohms differential.

3.3 Tracking Topologies

The tracking topologies required to maintain a consistent differential impedance of 100 ohms to the signal placed on the transmission line are limited to Stripline and Microstrip types. The designer must decide whether the signalling must be moved to an outer layer of the board using a Microstrip topology, or if the signalling may be placed on an inner layer as stripline where shielding by ground and power planes above and below is possible.



In order to prevent consuming received eye margin, the \pm track skew of a lane should be constrained to a maximum of 15pS.



The skew limitation between the shortest lane and longest lane of the RX or TX of a port is 22 ns.

3.3.1 Stripline

The RapidIO buses should be routed in a symmetrical edge-coupled stripline structure in order to ensure a constant impedance environment. The symmetrical stripline construction is shown in [Figure 5](#). This method also provides clean and equal return paths through VSS and VDD from the I/O cell of the Tsi578 to the adjacent RapidIO device. The use of broadside coupled stripline construction as shown in [Figure 7](#) is discouraged because of its inability to maintain a constant impedance throughout the entire board signal layer.

The minimum recommended layer count of a board design consists of 12 layers. The optimum design consists of 16 layers. The designer should consider both of these designs and weigh their associated costs versus performance.

Figure 5: Recommended Edge Coupled Differential Stripline (symmetric when $h1=h2$)

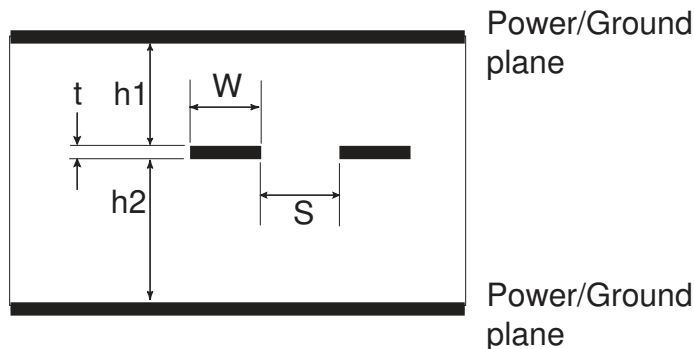

Figure 6: Equations for Stripline and Differential Stripline Impedance (in Ohms):

$$Z_o = \frac{60}{\sqrt{\mathcal{E}_r}} \times \ln \left(\frac{1.9(2(h_1 + h_2) + t)}{0.67 \pi (0.8 w + t)} \right)$$

$$Z_{diff} = 2 \times Z_o \left(1 - 0.374 e^{-2.9 \left[\frac{s}{h_1 + h_2} \right]} \right)$$

The broadside coupled stripline construction is not recommended for use with RapidIO because of the manufacturing variations in layer spacings. These variations will cause impedance mismatch artifacts in the signal waveforms and will degrade the performance of the link.

Figure 7: Not Recommended Broadside Coupled or Dual Stripline Construction

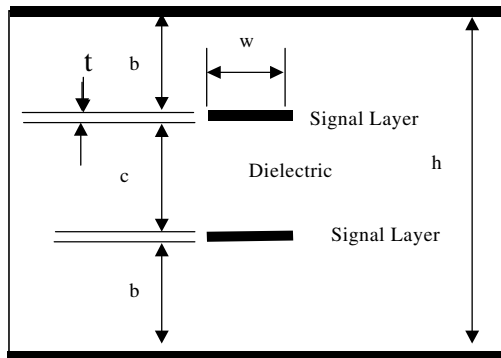

3.3.1.1 Microstrip

When it is necessary to place the differential signal pairs on the outer surfaces of the board, the differential microstrip construction is used. Figure 8 shows the construction of the microstrip topology. Below the figure are the design equations for calculating the impedance of the trace pair.

Figure 8: Differential Microstrip Construction

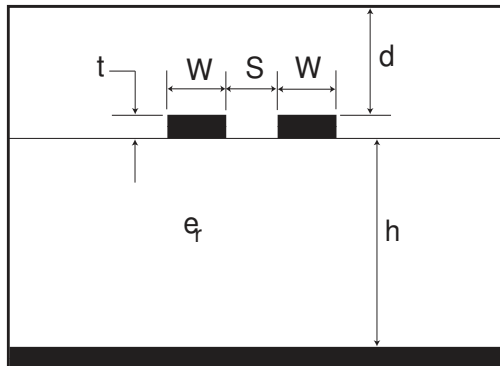

Figure 9: Equations for the Differential Microstrip Construction:

$$Z_o = \frac{60}{\sqrt{0.475\epsilon_r + 0.67}} \ln \left[\frac{4h}{0.67(0.8w + t)} \right] \text{ohms}$$

$$Z_{diff} \cong 2Z_o \left(1 - 0.48e^{-0.96\frac{s}{h}} \right) \text{ohms}$$

3.3.1.2 Signal Return Paths

The return path is the route that current takes to return to its source. It can take a path through ground planes, power planes, other signals, or integrated circuits. The return path is based on electro-magnetic field effects. The return path follows the path of least resistance nearest to the signal conductor. Discontinuities in the return path often have signal integrity and timing effects that are similar to the discontinuities in the signal conductor. Therefore, the return paths need to be given similar consideration.

A simple way to evaluate return path parasitic inductance is to draw a loop that traces the current from the driver through the signal conductor to the receiver, then back through the ground/power plane to the driver again. The smaller the area of the loop, the lower the parasitic inductance.

If via densities are large and most of the signals switch at the same time (as would be the case when a whole data group switches layers), the layer to layer bypass capacitors may fail to provide an acceptably short signal return path to maintain timing and noise margins.

When the signals are routed using symmetric stripline, return current is present on both the VDD and VSS planes. If a layer change must occur, then both VDD and VSS vias must be placed as close to the signal via as possible in order to provide the shortest possible path for the return current.

The following return path rules apply to all designs:

- Always trace out the return current path and provide as much care to the return path as the path of the signal conductor.
- Do not route impedance controlled signals over splits in the reference planes.
- Do not route signals on the reference planes in the vicinity of system bus signals.
- Do not make signal layer changes that force the return path to make a reference plane change.
- Decoupling capacitors do not adequately compensate for a plane split.
- Do not route over via anti-pads or socket anti-pads.

If reference plane changes must be made:

- Change from a VSS reference plane to another VSS reference plane and place a minimum of one via connecting the two planes as close as possible to the signal via. This also applies when making a reference plane change from one VDD plane to another VDD plane.
- For symmetric stripline, provided return path vias for both VSS and VDD.
- Do not switch the reference plane from VDD to VSS or vice versa.

3.3.1.3 Guard Traces

Guard traces are used to minimize crosstalk. Guard traces are tracks that run parallel to a signal trace for the entire length and are connected to the reference plane to which the signal(s) are associated. Guard traces can lower the radiated crosstalk by as much as 20dB.

The use of guard tracks requires some planning and foresight. The guard tracks will consume board real estate but in a dense routing where the potential for crosstalk is present, guard traces will save overall space that would have been consumed by separation space. Simulation has shown that a 5 mil ground trace with 5 mil spaces between the aggressor and receptor traces offers as much isolation as a 20 mil space between aggressor and receptor traces. The aggressor trace is the trace with a driven waveform on it. The receptor trace is the trace onto which the crosstalk is coupled.

Guard tracks are required to be stitched or connected with vias, to the reference plane associated with the signal. To ensure that there is no resonance on the guard traces, the stitching vias should be spaced at intervals that equal 1/20th of the 3rd harmonic.

Figure 10: Equation

$$\lambda = \sqrt{\epsilon_r} \times \frac{c}{f}$$

$$\frac{1}{20} \lambda_{3rd} = \frac{3 \times 10^8 \text{ m/s}}{20 \times f_{3rd} \sqrt{\epsilon_r}}$$

In the case of the 3.125 Gb/s data rate, the rise and fall times must be less than 40 pS. This relates to an upper frequency of 25 GHz and a corresponding wavelength of 25 mm based on a permittivity of 4.3. Therefore, the stitching vias must not be further apart than 8 mm.

3.3.1.4 Via Construction

Due to the high frequency content of the Serial RapidIO signals, it is necessary to minimize the discontinuities imposed by crossing ground and power planes when it is necessary to transition to different signal layers. The use of a controlled impedance via is recommended. The construction of a differential via is shown in [Figure 11](#).



Detailed design information can be found in bibliography entry 15, “*Designing Controlled Impedance Vias*” by Thomas Neu, EDN Magazine October 2, 2003.

Figure 11: Differential Controlled Impedance Via

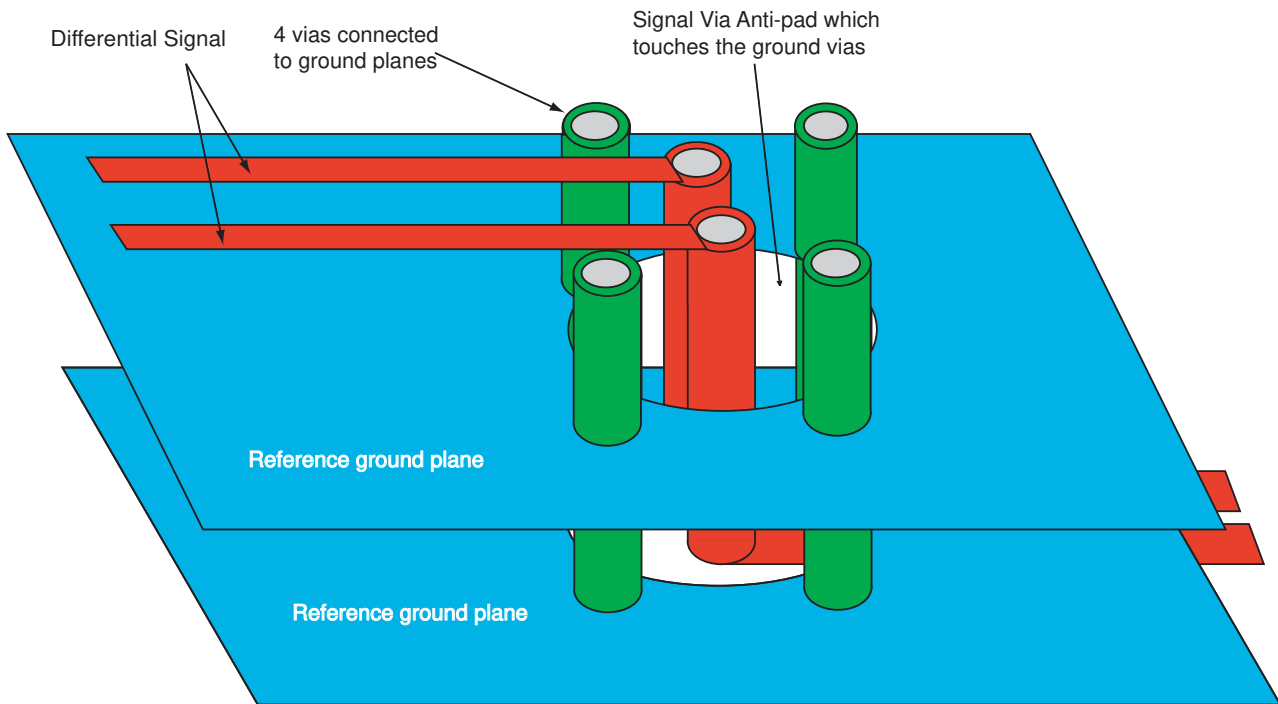

3.3.1.5 Layer Transitioning with Vias

The basic rule in high speed signal routing is to keep vias in the signal path down to a minimum. Vias can represent a significant impedance discontinuity and should be minimized. When routing vias, try to ensure that signals travel through the via rather than across the via.

A via where the signal goes through the via, has a much different effect than a via where the signal travels across the via. These two cases are shown in [Figure 15](#) and in [Figure 16](#). The “in” and “out” nodes of the via model are shown on their corresponding locations in the figures.

Transitioning across a via that is not blind or buried leaves a stub which appears as a capacitive impedance discontinuity. The portion of the via that conducts current appears inductive while the stub that develops only an electric field will appear capacitive.

In order to minimize the effects of a via on a signal, the following equations may be used to approximate the capacitance and inductance of the via design. It can be seen that the proximity of the pad and antipad have a direct relationship on the capacitance, and that the length of the barrel (h) has a direct effect on the inductance.

Figure 12: Equation 1

$$L = 5.08h \left[\ln \left(\frac{4h}{d} \right) + 1 \right]$$

Equation parameters:

- L is the inductance in nH.
- h is the overall length of the via barrel.
- d is the diameter of the via barrel.

Figure 13: Equation 2

$$C = \frac{1.41 \varepsilon_r T D_1}{D_2 - D_1}$$

Equation parameters:

- C is the capacitance in pF.
- T is the thickness of the circuit board or thickness of pre-preg.
- D_1 is the diameter of the via pad.
- D_2 is the diameter of the antipad.
- ε_r is the dielectric constant of the circuit board material.

Figure 14: Via Construction

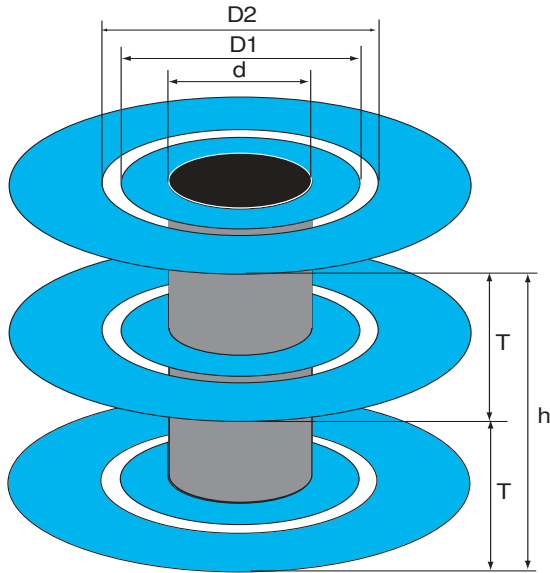

Figure 15: Signal Across a Via

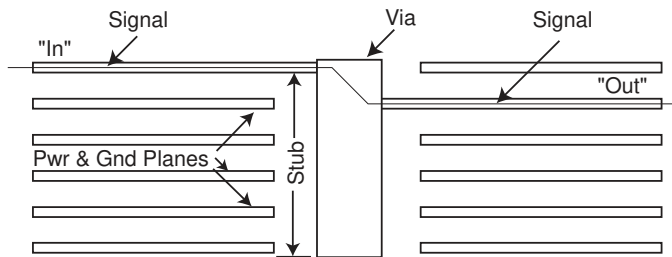
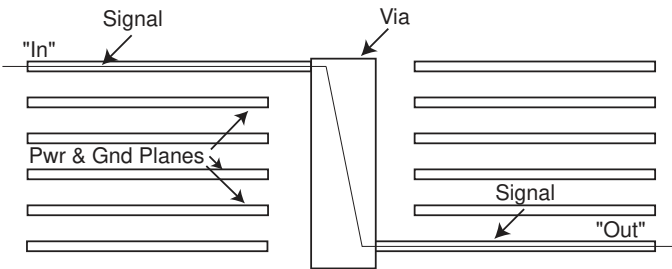

Figure 16: Signal Through a Via



Because of the high frequencies present in the RapidIO signal, vias become a significant contributor to signal degradation. Most vias are formed by a cylinder going through the PCB board. Because the via has some length, there is an inductance associated with the via. Parasitic capacitance comes from the power and ground planes through which the via passes. From this structure, the model of the vias in RLC lumps as shown in [Figure 17](#) and [Figure 18](#).

The figure parameters are:

- C_{via} is the total capacitance of the via to ground or power
- R_{via} is the total resistance through the via, and L_{via} is the total inductance of the via.

These parameters may be extracted using 3D parasitic extraction tools. By distributing the R, L, and C, the model better represents the fact that the capacitance, resistance and inductance are distributed across the length of the via. For the Via model to be accurate in simulation, the propagation delay of each LC section should be less than 1/10 of the signal risetime. This is to ensure the frequency response of the via is modeled correctly up to the frequencies of interest. More information may be found in reference [16].

Figure 17: Signal Transitioning Across a Via Simulation Model

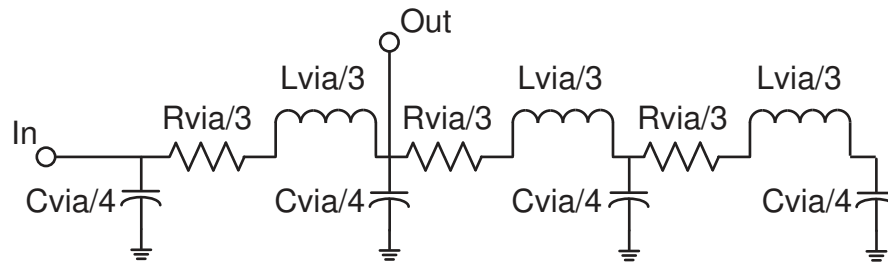
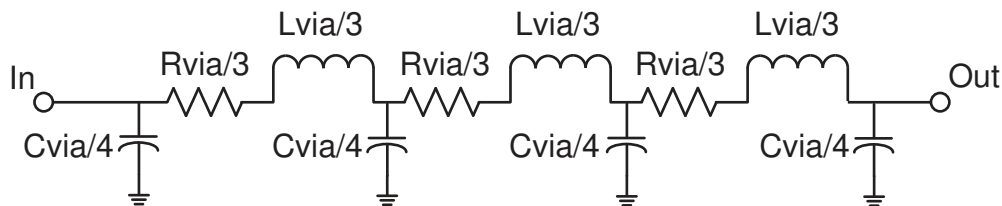

Figure 18: Signal Transitioning Through a Via Simulation Model



3.3.1.6 Buried Vs. Blind

The use of buried and blind vias is recommended because in both cases the signal travels through the via and not across it. Examples of these two types of structures are shown in [Figure 19](#) and [Figure 20](#).

Figure 19: Buried Via Example

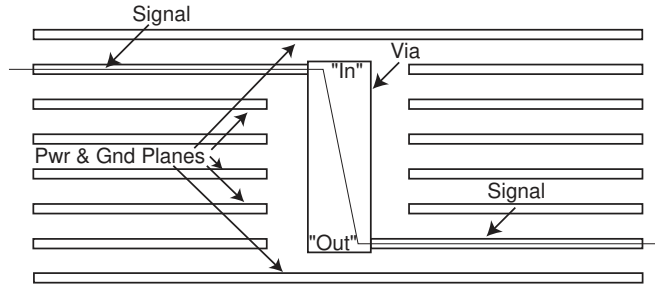
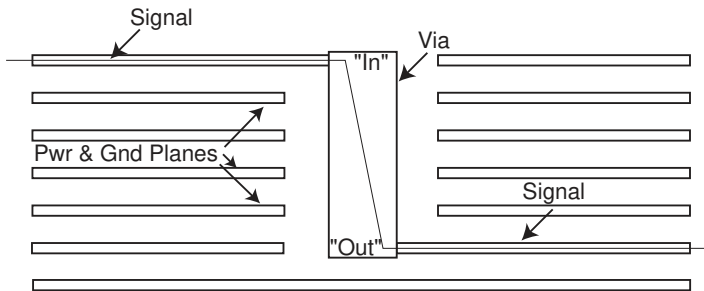

Figure 20: Blind Via Example



3.3.1.7 Serpentine Traces

During layout, it is necessary to adjust the lengths of tracks in order to accommodate the requirements of equal track lengths for pairs of signals. In the case of the differential signals, this ensures that both the negative and positive halves of the signals arrive at the receiver simultaneously, thus maximizing the data sampling window in the eye diagram. Creating a serpentine track is a method of adjusting the track length.

Ensure that the wave front does not propagate along the trace and through the crosstalk path perpendicular to the parallel sections, as shown in [Figure 21](#). The arrival of a wave front at the receiver ahead of the wave front traveling along the serpentine route is caused by the self-coupling between the parallel sections of the transmission line (L_p).

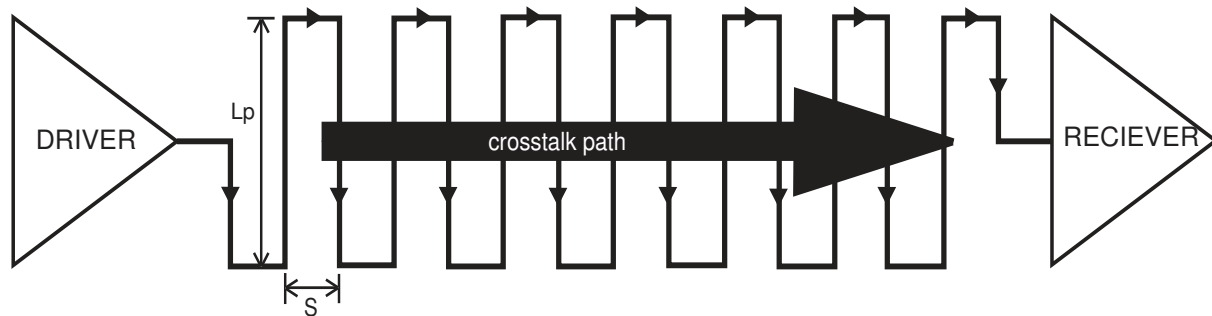
Figure 21: Serpentine Signal Routing

To maximize the signal integrity, clock lines should not be serpentine.

Figure 24 describes the guidelines for length matching a differential pair. If it is necessary to serpentine a trace, follow these guidelines:

- Make the minimum spacing between parallel sections of the serpentine trace (see “S” in Figure 21) at least 3 to 4 times the distance between the signal conductor and the reference ground plane.
- Minimize the total length (see “Lp” in Figure 21) of the serpentine section in order to minimize the amount of coupling.
- Use an embedded microstrip or stripline layout instead of a microstrip layout.



For a detailed discussion about serpentine layouts, refer to Section 12.8.5 of “*High-Speed Signal Propagation, Advanced Black Magic*” by Howard Johnson and Martin Graham.

3.3.2 Crosstalk Considerations

The Serial RapidIO signals easily capacitively couple to adjacent signals due to their high frequency. It is therefore recommended that adequate space be used between different differential pairs, and that channel transmit and receive be routed on different layers. Cross coupling of differential signals results in an effect called Inter-Symbol Interference (ISI). This coupling causes pattern dependent errors on the receptor, and can substantially increase the bit error rate of the channel.

3.3.3 Receiver DC Blocking Capacitors

The Serial RapidIO interface requires that the port inputs be capacitor coupled in order to isolate the receiver from any common mode offset that may be present in the transmitter outputs. DC blocking capacitors should be selected such that they have low dissipation factor and low series inductance. The recommended capacitor value is 0.1 μ F ceramic in an 0402 size.

Figure 22 shows the recommended tracking and capacitor pad placement required. It will be necessary to model and simulate the effects of the changed track spacing on the channel quality and determine if any changes are required to the topology. An often used method of correcting the decreased impedance caused by the larger capacitor mounting pads is to create a slot in the shield plane below the capacitor bodies and soldering pads. Since the impedance change caused by the slot is dependent on the capacitor geometry, core thickness, core material characteristics and layer spacings, the size and shape of the slot will have to be determined by simulation.



Do not place the capacitors along the signal trace at a $\lambda/4$ increment from the driver in order to avoid possible standing wave effects.

Figure 22: Receiver Coupling Capacitor Positioning Recommendation

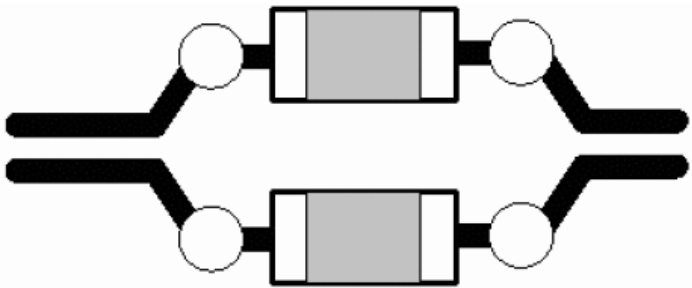

3.3.4 Escape Routing

All differential nets should maintain a uniform spacing throughout a route. Separation of differential pairs to go around objects should not be allowed. **Figure 23** illustrates several options for breaking out a differential pair from the Tsi578 device. The order of preference is from A to D.

Case D below has a small serpentine section used to match the inter-pair skew of the differential pair. In this case each serpentine section should be greater than $3 \times W$ (W =width), and the gap should not increase by more than $2x$. **Figure 24** illustrates these requirements.

Figure 23: Escape Routing for Differential Signal Pairs

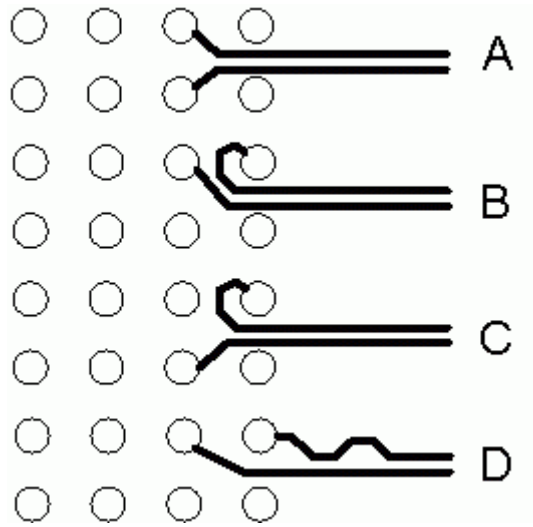
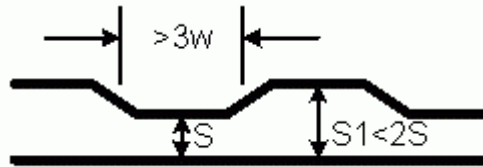

Figure 24: Differential Skew Matching Serpentine



3.3.5 Board Stackup

The recommended board stack up is shown in [Figure 25](#). This design makes provision for four stripline layers and two outer microstrip layers. Layers eight and nine are provisioned as orthogonal low speed signal routing layers.

Figure 25: Recommended Board Stackup

Layers	Thks.	Cross Section Diagram	Layer Type	Layer Definition	stripline		edge coupled diff	
					Trace Width	Impedance	Trace Width	Impedance
			mask					
L01	1.6		plating	PRI				
	0.6		.5oz foil					
	7.9		prepreg					
L02	1.2			pwr				
L03	2.0		1/1zbc					
L03	1.2			gnd				
	5.3		prepreg					
L04	0.6			sig	5	50.0 Ω	4line6sp	100.0 Ω
L05	5.0		.5/1core					
L05	1.2			gnd				
	5.3		prepreg					
L06	0.6			sig	5	50.0 Ω	4line6sp	100.0 Ω
L07	5.0		.5/1core					
L07	1.2			gnd				
	4.4		prepreg					
L08	0.6			sig	5	50.0 Ω		
L09	5.0		.5/.5core					
L09	0.6			sig	5	50.0 Ω		
	4.4		prepreg					
L10	1.2			gnd				
L11	5.0		.5/1core					
L11	0.6			sig	5	50.0 Ω	4line6sp	100.0 Ω
	5.3		prepreg					
L12	1.2		.5/1core					
L13	0.6			sig	5	50.0 Ω	4line6sp	100.0 Ω
	5.3		prepreg					
L14	1.2			gnd				
L15	2.0		1/1zbc					
L15	1.2			pwr				
	7.9		prepreg					
L16	0.6		.5 oz foil	sec				
	1.6		plating					
			mask					
Total:	88	Finish thickness over laminate +10%						
	92	Finish thickness over plating +10%						

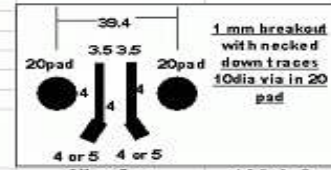

3.4 Power Distribution

The Tsi578 is a high speed device with both digital and analogue components in its design. The core logic has a high threshold of noise sensitivity within its 1.2 V operating range. However, the analogue portion of the switch is considerably more sensitive.

The correct treatment of the power rails, plane assignments, and decoupling is important to maximize Tsi578 performance. The largest indicator of poor performance on the Serial RapidIO interfaces is the presence of jitter. The die, I/O, and package designs have all been optimized to provide jitter performance well below the limits required by the Serial RapidIO specifications. The guidelines provided below will assist the user in achieving a board layout that will provide the best performance possible. The required decoupling by each voltage rail can be found in [“Electrical Characteristics” on page 29](#). The ripple specifications for each rail are maximums, and every effort should be made to target the layout to achieve lower values in the design.

A solid, low impedance plane must be provided for the VDD 1.2V core supply referenced to VSS. It is strongly recommended that the VDD and VSS planes be constructed with the intent of creating a buried capacitance. The connection to the power supply must also be low impedance in order to minimize noise conduction to the other supply planes.

A solid, low impedance plane must be provided for the SP_VDD 1.2V SerDes supply, referenced to the VSS plane. This supply can be derived from the same power supply as VDD, as long as a *Kelvin connection* is used. The preference however, is to use a separate power supply.



The term *Kelvin connection* is used to describe a single point of contact so that power from one power plane does not leak past the power supply pin into the other power plane. The leakage can be prevented by the fact the output of a power supply is a very low impedance point in order to be able to supply a large amount of current. Because it is such a low impedance point, any noise presented to it by the power plane is sent to ground.

A kelvin connection enables two power planes to be connected together at a single point. Using this technique, the same power supply module can be used to provide power to a noisy digital power plane (VDD), as well as a quiet analog power plane (SP_VDD).

Figure 26: Kelvin Connection Example

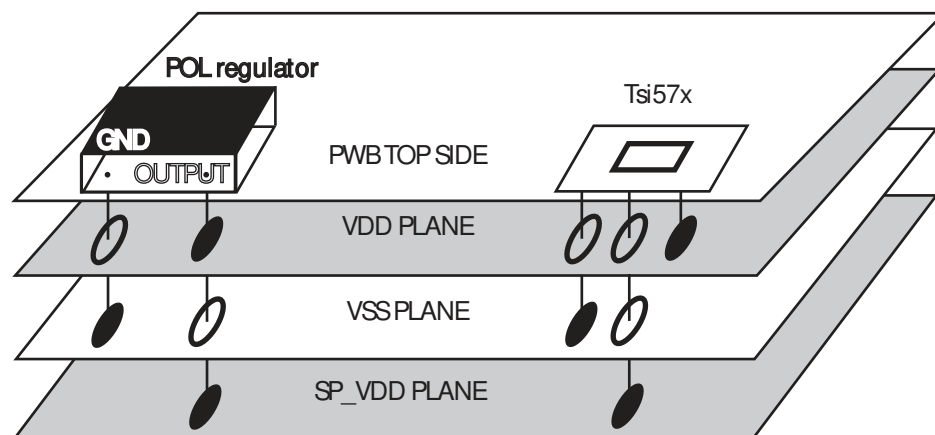

Example of connection points described as a Kelvin Connection
VDD and SP_VDD planes are only connected to each other at the
POL regulator output pin.

The SP_AVDD 3.3V SerDes analogue supply also needs low impedance supply plane. This supply voltage powers the RapidIO receivers and transmitters, and their associated PLLs. Connect all of the SP_AVDD pins to this plane and decouple the plane directly to VSS. The plane must be designed as a low impedance plane in order to minimize transmitter jitter and maximize receiver sensitivity. Construction of this plane as a buried capacitance referenced to VSS is suggested.

The REF_AVDD pins provide power to the S_CLK distribution circuits in the switch. The voltage should be derived from the SP_VDD plane. One ferrite will suffice to isolate the SP_VDD from the REF_AVDD. Two decoupling capacitors should be assigned to each pin.

The VDD_IO supply powers the 3.3V I/O cells on the switch. This supply requires no special filtering other than the decoupling to the VSS plane.

3.5 Decoupling Requirements

This section deals with the subject of decoupling capacitors required by the Tsi578. To accomplish the goal of achieving maximum performance and reliability, the power supply distribution system needs to be broken down into its individual pieces, and each designed carefully. The standard model for representing the components of a typical system are shown in [Figure 27](#). This figure graphically represents the parasitics present in a power distribution system.

Figure 27: System Power Supply Model

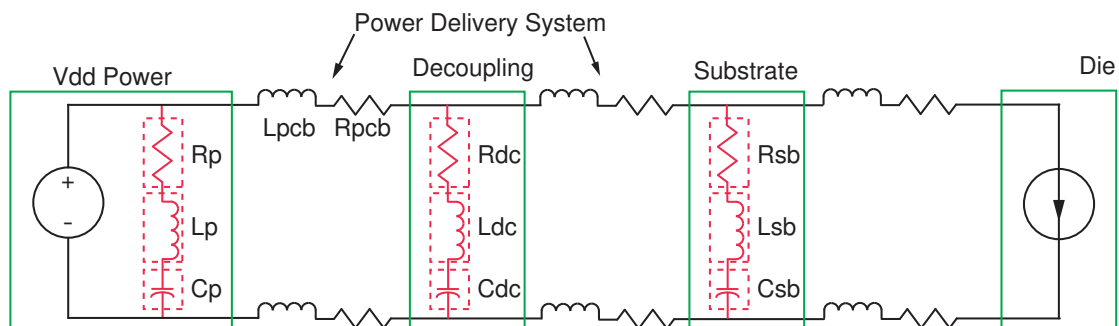

3.5.1 Component Selection

The recommended decoupling capacitor usage for the Tsi578 is shown in “[Electrical Characteristics](#)” on [page 29](#). The capacitors should be selected with the smallest surface mount body that the applied voltage permits in order to minimize the body inductance. Ceramic X7R type are suggested for all of the values listed. The larger value capacitors should be low ESR type.

The components should be distributed evenly around the device in order to provide filtering and bulk energy evenly to all of the ports.



Use the Tsi578 ball map (available at www.idt.com) to aid in the distribution of the capacitors.

3.5.1.1 REF_AVDD

The REF_AVDD pins require extra care in order to minimize jitter on the transmitted signals. The circuit shown in [Figure 28](#) is recommended for the REF_AVDD signal. One filter is required for the two pins.

Figure 28: PLL Filter

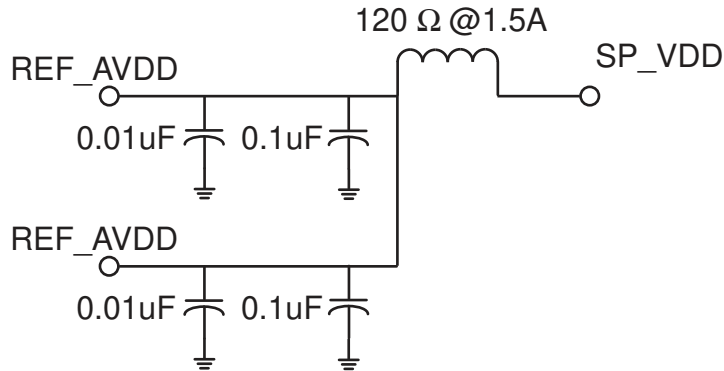

3.5.1.2 Power and REXT

The circuit in [Figure 29](#) shows the connection of the power rails as required by the device.

Figure 29: Power and REXT Diagram

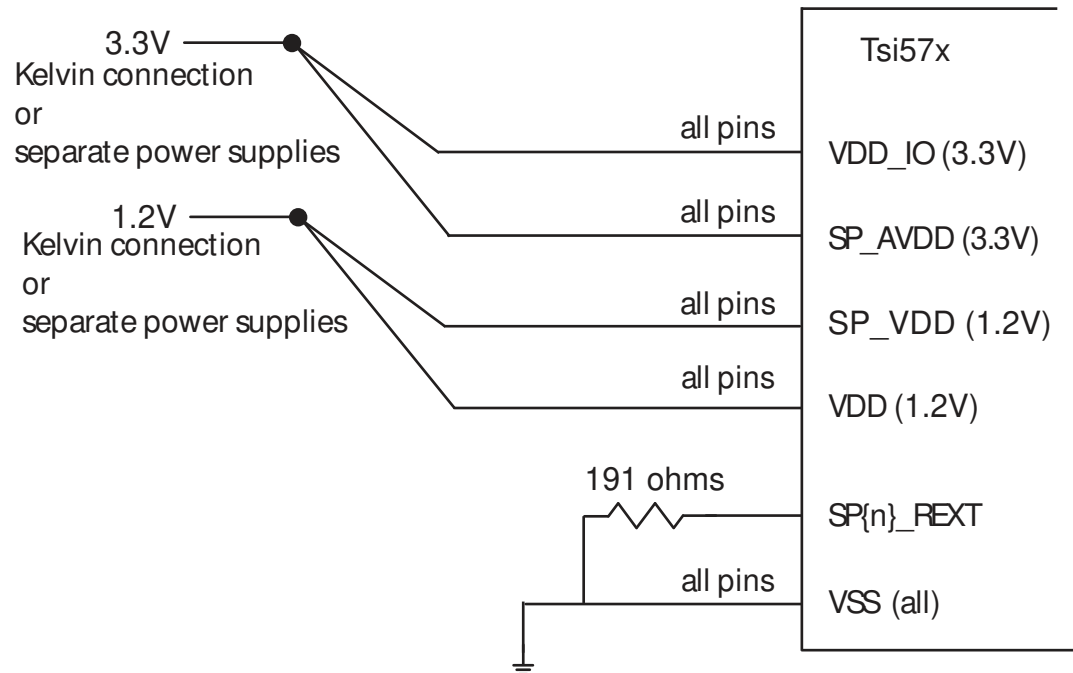

Table 17: Decoupling Capacitor Quantities and Values Recommended for the Tsi578

Voltage	Usage	Acronym	Component Requirements				
1.2V	Logic Core	VDD	20 x 0.1uF	20 x 0.01uF	16 x 1nF	-	16 x 22uF
1.2V	SerDes core, SerDes bias	SP_VDD	16 x 0.1uF	16 x 0.01uF	32 x 1nf	8 x 10uF	8 x 100uF
3.3V	SerDes transceivers	SPn_AVDD	16 x 0.1uF	16 x 0.01uF	-	-	-
3.3V	Single ended I/O ports	VDD_IO	12 x 0.1uF	12 x 0.01uF	-	-	-
1.2V	Clock distribution circuit	REF_AVDD	2 x 0.1uF	2 x 0.01uF	-	1 x ferrite bead 120 ohm @ 1.5Amp	

3.5.2 Effective Pad Design

Breakout vias for the decoupling capacitors should be kept as close together as possible. The trace connecting the pad to the via should also be kept as short as possible with a maximum length of 50mils. The width of the breakout traces should be 20mils, or the width of the pad.



Via sharing should not be used in board design with the Tsi578.

Figure 30: Recommended Decoupling Capacitor Pad Designs

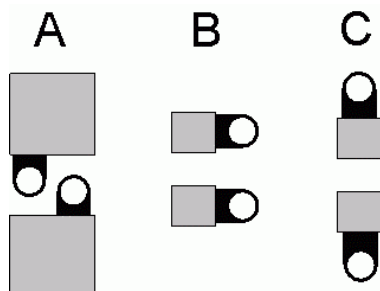

3.5.3 Power Plane Impedance and Resonance

The intent of adding decoupling to a board is to lower the impedance of the power supply to the devices on the board. It is necessary to pay attention to the resonance of the combined bulk capacitance and to stagger the values in order to spread the impedance valleys broadly across the operating frequency range. [Figure 32](#) demonstrates the concept of staggered bands of decoupling. Calculate the impedance of each of the capacitor values at the knee frequency to determine their impact on resonance.

Figure 31: Equation

$$F_{knee} = \frac{0.5}{T_{rise}} \text{ where } T_{rise} = \text{time from 10\% to 90\%}$$

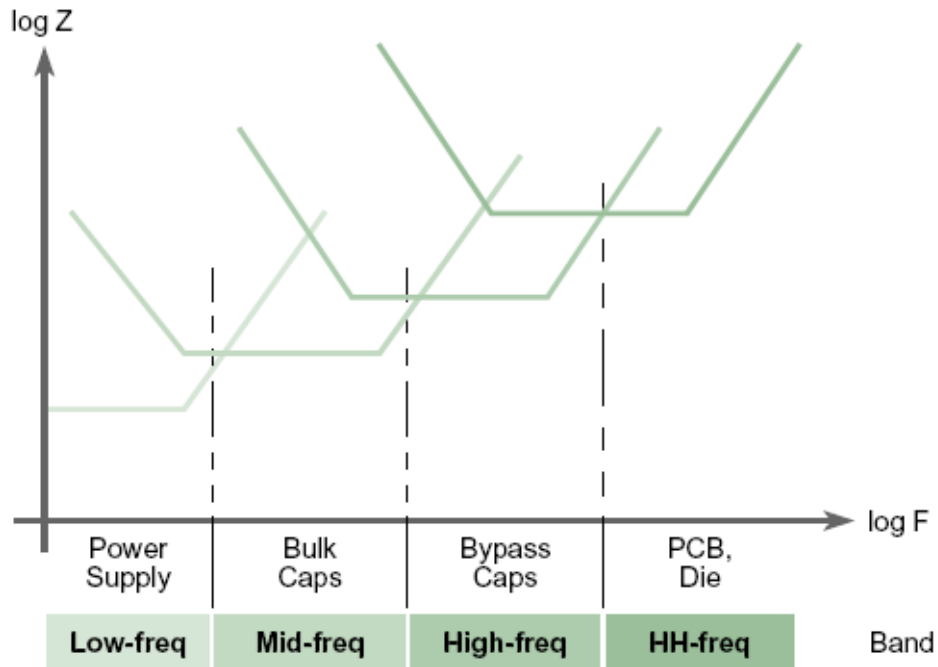
Figure 32: Decoupling Bypass Frequency Bands

As the frequency changes, each part of the power distribution system responds proportionally; the low-impedance power supply responds to slow events, bulk capacitors to mid-frequency events, and so forth.

3.6 Clocking and Reset

This section discusses the requirements of the clock and reset inputs.

3.6.1 Clock Overview

The Tsi578 switch input reference clocks that are used to drive the switch's internal clock domains.

Figure 33: Tsi578 Clocking Architecture

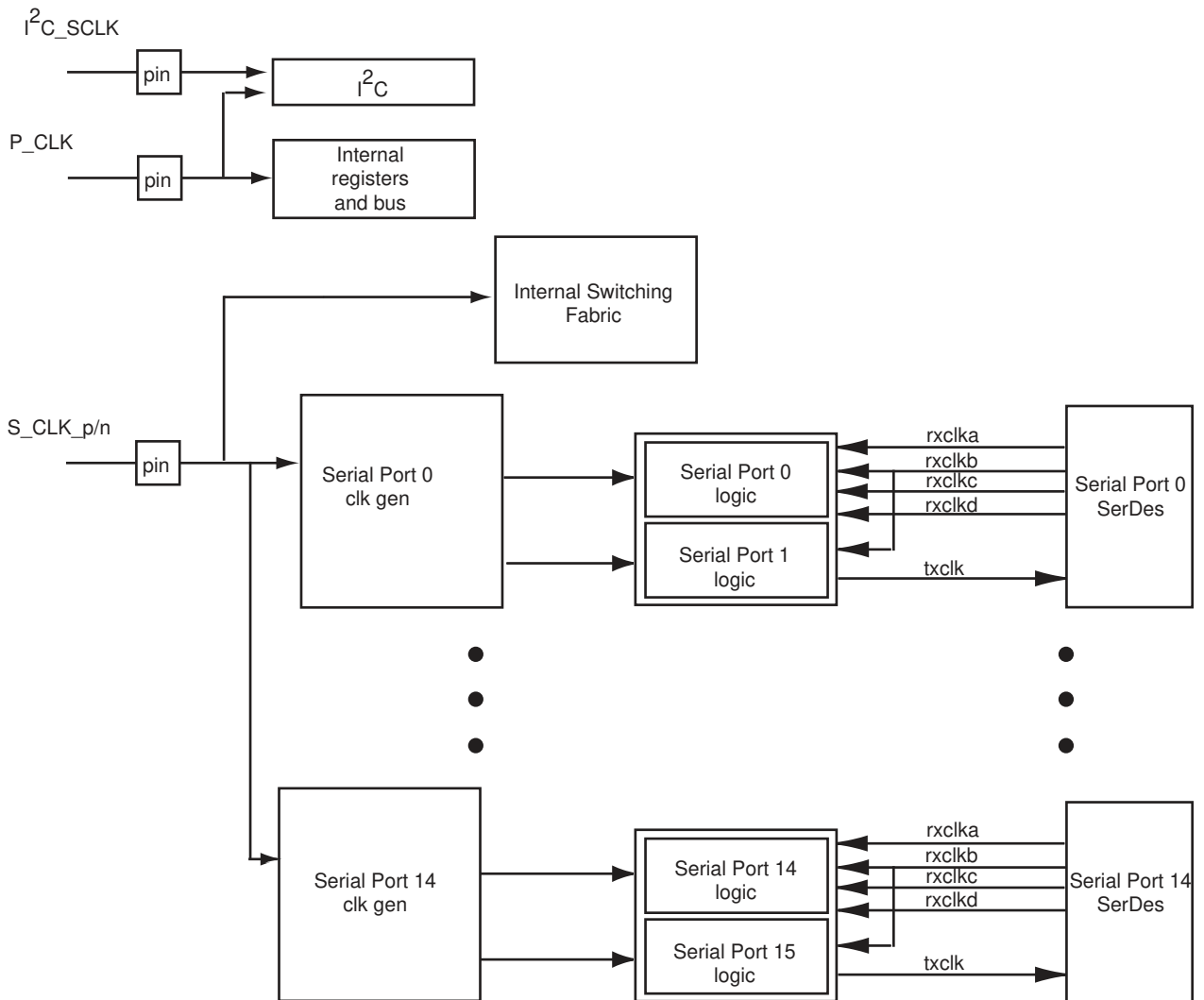

The reference clocks are described in [Table 18](#). For more information about special line rate support see [“Clocking” on page 71](#).

Table 18: Clock Input Sources

Clock Input Pin	Type	Maximum Frequency	Clock Domain
S_CLK_[p/n]	Differential	156.25 MHz	Serial Transmit Domain (Nominally 156.25MHz) Internal Switching Fabric (ISF) Domain For more information on programming the S_CLK operating frequency, refer to “Line Rate Support” on page 71 .
P_CLK	Single Ended	100 MHz	Internal Register Domain and I ² C Domain For more information on programming the P_CLK operating frequency, refer to “P_CLK Programming” on page 75 .

3.6.1.1 Clock Sources

The clock signals should be shielded from neighboring signal lines using ground traces on either side. This reduces jitter by minimizing crosstalk from the neighboring signal lines. Since P_CLK is single-ended, extra precaution should be taken so that noise does not get coupled onto it.

In order to preserve the quality of the low jitter 156.25 MHz clock, the shielding requirement of the clock lines is critical. It is possible that low-frequency noise can interfere with the operation of PLLs, which can cause the PLLs to modulate at the same frequency as the noise. The high-frequency noise is generally beyond the PLL bandwidth which is about 1/10th the S_CLK frequency. For more information, refer to [Figure 3 on page 37](#).

3.6.1.2 Stability, Jitter and Noise Content

The maximum input jitter on the S_CLK input is 3pS RMS from 1.5 to 10 MHz to avoid passing through the PLL loop filter in the SerDes and affecting the transmit data streams. The maximum input jitter allowable on the P_CLK input is 300 pSpp. Jitter on this input would be reflected outside of the chip on the I²C bus. For more information, refer to [Figure 3 on page 37](#).

Jitter Equation

The following equation can be used to convert Phase Noise in dBc to RMS jitter:

$$\text{RMSjitter pS(rms)} = [((10^{(\text{dBc}/10)})^{1/2}) * 2] / [2 * \text{pi} * (\text{frequency in hz})]$$

Using this equation, an example of 312.5 MHz and a phase noise of -63dBc, would produce 0.72pS RMS jitter.

3.6.2 Clock Domains

Table 19: Tsi578 Clock Domains

Clock Domain	Clock Source	Description
Internal Register Domain	P_CLK	This clock domain includes all of the internal registers and their interconnect bus. The domain uses the input P_CLK directly. For more information on programming the P_CLK operating frequency, refer to “P_CLK Programming” on page 75 .
Internal Switching Fabric Domain	S_CLK_[p/n]	This clock domain includes the switching matrix of the ISF and the portion of each RapidIO block that interfaces to the ISF.
I ² C Domain	P_CLK divided by 1000	This clock domain is responsible for driving the I2C output clock pin I2C_SCLK. This clock domain is generated by dividing the P_CLK input by 1000. The majority of the I ² C logic runs in the Internal Register Domain
Serial Transmit Domain	S_CLK_[p/n]	This clock domain is used to clock all of the Serial RapidIO transmit ports.

3.6.2.1 Interfacing to the S_CLK_x Inputs

The interface for a LVPECL clock source to the receiver input cell is shown in Figure 34. In the diagram, an AC-coupled interface is required to ensure only the AC information of the clock source is transmitted to the clock inputs of the Tsi578.

Two 150 ohm resistors are used in the diagram because LVPECL outputs need DC biasing and a DC path for the source current. The requirements for DC biasing when interfacing a clock driver's output to a CML input should be checked with the suppliers of the clock driver.

Figure 34: LVPECL Clock Source to a Receiver Input Cell

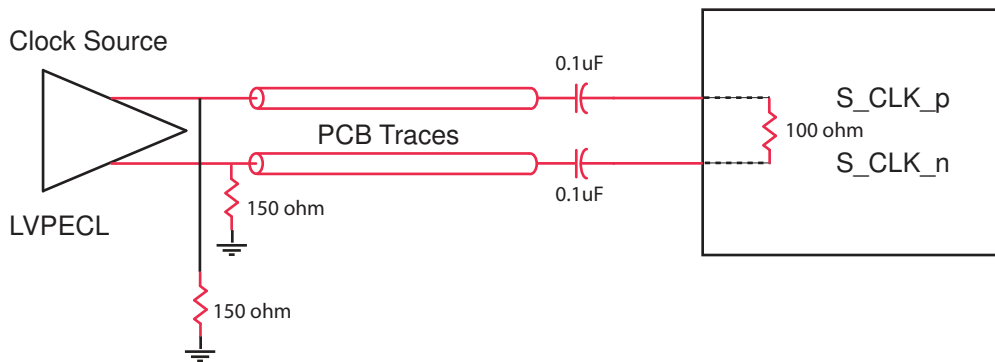

3.6.3 Reset Requirements

The Tsi578 requires only one reset input, HARD_RST_b. The signal provided to the device must be a monotonic 3.3V swing that de-asserts a minimum of 1mS after supply rails are stable. The signal de-assertion is used to release synchronizers based on P_CLK which control the release from reset of the internal logic. P_CLK must therefore be operating and stable before the 1mS HARD_RST_b countdown begins.



TRST_b must be asserted while HARD_RST_b is asserted following a device power-up to ensure the correct setup of the tap controller. TRST_b is not required to be re-asserted for non power cycle assertions of HARD_RST_b

The most versatile solution to this requirement is to AND the HARD_RST_b and TRST_b signals together to form an output to drive the TRST_b pin on the switch.

Power up option pins are double sampled at the release of HARD_RST_b. As such, there is no set-up time requirement, but the signals must be stable at the release of HARD_RST_b. There is a hold time requirement of 100nS or 10 P_CLK cycles minimum.

3.7 Modeling and Simulation

Verifying the signal integrity of the board design is very important for designs using GHz signalling. IDT recommends that the designer invest in a simulation tool as an aid to a successful RapidIO design. Tools are available from companies such as Mentor Graphics (HyperLynx GHZ), Ansoft (SIwave) and SiSoft (SiAuditor).

3.7.1 IBIS

The use of IBIS for signal integrity checking at the high frequencies of the Serial RapidIO link have been found to be too inaccurate to be useful. Also, we have found that most tools do not yet support the *IBIS Specification (Revision 3.2)* for the support of multi-staged slew rate controlled buffers.

Contact IDT, at www.idt.com, for an IBIS file which supports the LVTTTL pins on the device.

3.7.2 Encrypted HSPICE

Contact IDT, at www.idt.com, to request the Model License Agreement form required to acquire the encrypted model.

3.8 Testing and Debugging Considerations

Making provisions for debugging and testing tools speeds-up board bring-up. This section provides information on the probing requirements for monitoring the serial RapidIO link between two devices. At GHz frequencies, standard probing techniques are intrusive and cause excessive signal degradation introducing additional errors in the link stream. The recommended solution is an ultra low capacitance probe that operates in conjunction with a logic analyzer. The addition of the appropriate disassembler software to the analyzer makes it a very powerful tool for examining the traffic on a link and aiding in software debugging. Please contact your local test equipment vendor for appropriate solutions for your requirements.

3.8.1 Logic Analyzer Connection Pads

The pinout for a recommended Serial RapidIO 8-channel probe is shown in [Table 20](#). This pin/signal assignment has been adopted by several tool vendors but is not an established standard.

The following notes apply:

Footprint Channel versus Lane/Link Designations

- Channel = either an upstream OR downstream differential pair for a given lane
- C<letter> = the designator for a channel which accepts a given differential pair of signals
- C<letter><p or n> = the two signals of the differential pair. The signals within a given pair may be assigned to either P or N regardless of polarity.

3.8.1.1 General Rules for Signal Pair Assignment of Analyzer Probe

The differential pairs that make up the Serial RapidIO links must be assigned to specific pins of the footprint in order to take advantage of the pre-assigned channel assignments provided by Nexus when purchasing the Serial RapidIO pre-processor.

Table 20: 8-Channel Probe Pin Assignment

Pin Number	Signal Name	Pin Number	Signal Name
2	GND	1	CAp/Tx0
4	CBp/Rx0	3	CAn/Tx0
6	CBn/Rx0	5	GND
8	GND	7	CCp/Tx1
10	CDp/Rx1	9	CCn/Tx1
12	CDn/Rx1	11	GND

Table 20: 8-Channel Probe Pin Assignment

Pin Number	Signal Name	Pin Number	Signal Name
14	GND	13	CEp/Tx2
16	CFp/Rx2	15	CEn/Tx2
18	CFn/Rx2	17	GND
20	GND	19	CGp/Tx3
22	CHp/Rx3	21	CGn/Tx3
24	CHn/rX3	23	GND

Figure 35: Analyzer Probe Pad Tracking Recommendation

Figure 36: Analyzer Probe Footprint

- 1 MUST MAINTAIN A SOLDERMASK WEB BETWEEN PADS WHEN TRACES ARE ROUTED BETWEEN THE PADS ON THE SAME LAYER. HOWEVER, SOLDERMASK MAY NOT ENCROACH ONTO THE PADS WITHIN THE PAD DIMENSIONS SHOWN.
- 2 VIA-IN-PAD NOT ALLOWED ON THESE PADS. HOWEVER, VIA EDGES MAY BE TANGENT TO THE PAD EDGES.
- 3 PERMISSABLE SURFACE FINISHES ON PADS ARE HASL, IMMERSION SILVER, OR GOLD OVER NICKEL.

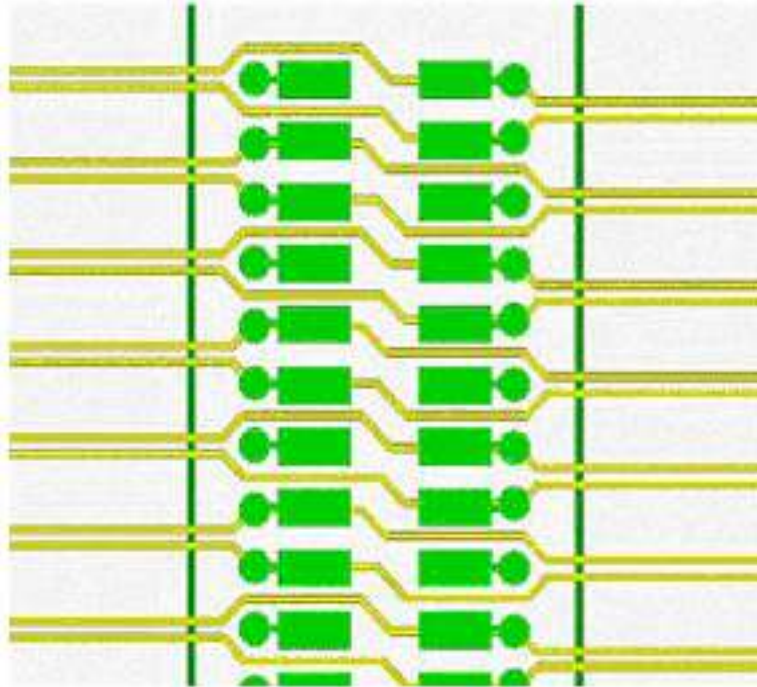
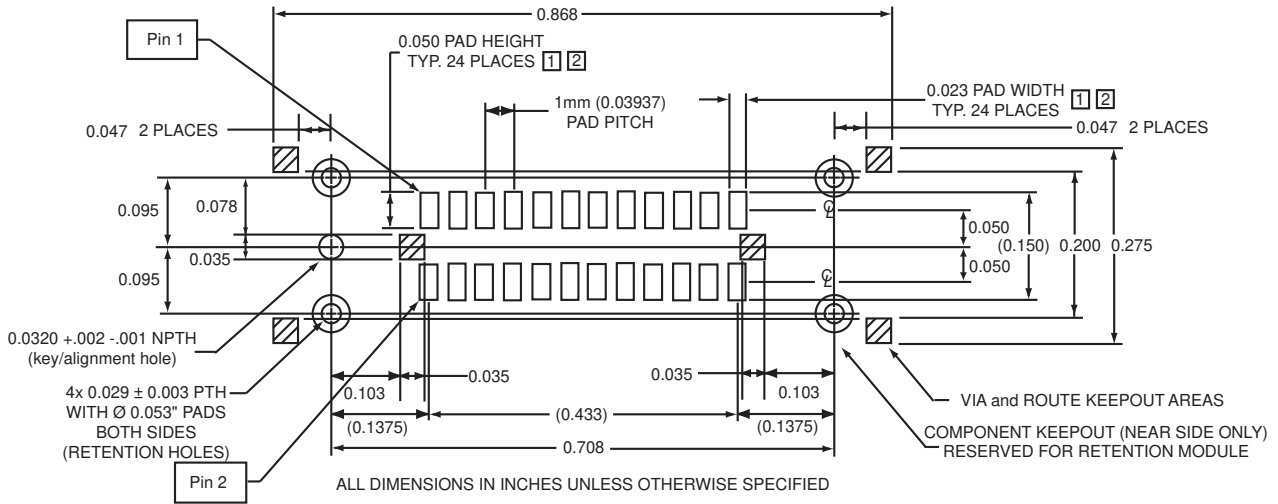

3.8.2 JTAG Connectivity

The Joint Test Action Group (JTAG) created the boundary-scan testing standard (documented in the *IEEE 1149.1 Standard*) for testing printed circuit boards (PCBs).

The boundary-scan approach involves designing boundary-scan circuitry into the integrated circuit. PCBs populated with 1149.1 compliant devices can be then tested for connectivity, correct device orientation, correct device location, and device identification. All the pins on compliant devices can be controlled and observed using (typically) five pins that are routed to the board edge connector. Board designers can develop a standard test for all 1149.1 compliant devices regardless of device manufacturer, package type, technology, or device speed.

In addition to the 1149.1 compliant boundary scan TAP controller, the Tsi578 also contains an 1149.6 compliant TAP controller to aid in the production testing of the SerDes pins.

The Tsi578 also has the capability to read and write all internal registers through the JTAG interface. Through this interface, users may load and modify configuration registers and look up tables without the use of RapidIO maintenance transactions or an I²C EEPROM.

3.9 Reflow Profile

The Tsi578 adheres to JEDEC-STD-020C for its reflow profile. For the leaded version, the peak reflow temperature is 225°C (+0/-5°C). For the lead-free version, the peak reflow temperature is 260°C (+0/-5°C).

A. Clocking

This appendix describes device behavior outside the *RapidIO Interconnect Specification (Revision 1.3)* recommended operating line rates and clock frequencies.

The following topics are discussed:

- “Line Rate Support” on page 71
- “P_CLK Programming” on page 75

A.1 Line Rate Support

The Tsi578 supports all of the *RapidIO Interconnect Specification (Revision 1.3)* specified line rates of 1.25, 2.50, and 3.125 Gbaud. The device also supports line rates that are outside of the RapidIO specification. The ability to support multiple line rates gives the Tsi578 flexibility in both application support and power consumption.

Table 21 shows the supported line rates for the Tsi578. The Serial Port Select pin, SP_IO_SPEED[1,0] must be set to the values shown in **Table 21** to achieve the documented line rates.

Table 21: Tsi578 Supported Line Rates ¹

S_CLK_p/n (MHz)	Baud Rate (Gbaud)	SP_IO_SPEED[1,0] Bit Settings	Register Settings
153.60	1.2288 CPRI Line Rate	0,0	-
153.60	1.536 OBSAI Line Rate	0,1	-
153.60	2.4576 CPRI Line Rate	0,1	-
153.60	3.0720 CPRI Line Rate	1,0	-
156.25	1.2500 Standard RapidIO Line Rate	0,0	-
156.25	2.5000 Standard RapidIO Line Rate	0,1	-
156.25	3.1250 Standard RapidIO Line Rate	1,0	-

Table 21: Tsi578 Supported Line Rates (Continued)¹

S_CLK_p/n (MHz)	Baud Rate (Gbaud)	SP_IO_SPEED[1,0] Bit Settings	Register Settings
125.00	1.2500 Standard RapidIO Line Rate	0,1	-
125.00	2.5000 Standard RapidIO Line Rate	1,0	-
125.00	3.1250 Standard RapidIO Line Rate	1,0	See “Register Requirements Using 125 MHz S_CLK for a 3.125 Gbps Link Rate” on page 72

1. This information assumes a +/- 100 ppm clock tolerance that must be obeyed between link partners.

All bit and register settings that are documented for operation with S_CLK = 156.25 MHz also apply to the use of 153.6 MHz and 125 MHz. For more clocking information, see “Clocks” in the *Tsi578 User Manual*.

A.1.1 Register Requirements Using 125 MHz S_CLK for a 3.125 Gbps Link Rate

In order to use S_CLK at 125 MHz to create a 3.125 Gbps link baud rate, the default values in the SerDes PLL Control Register must be modified from a x20 multiplier to a x25 multiplier. On power-up, the default PLL multipliers of x20 causes the 125 MHz source to create a 2.5 Gbps link rate. Changing this link rate to 3.125 Gbps requires either intervention by the I²C boot EEPROM during boot loading to reconfigure the SerDes, or the intervention of an external host to modify the SerDes registers through the use of maintenance transactions. However, modifying by EEPROM is the recommended method.



The SerDes PLL Control Registers are volatile. Applying HARD_RST_b or asserting PWRDN_x4 results in the SerDes PLL Control Register default value being re-applied.

A.1.1.1 Modification by EEPROM Boot Load

Modifying the EEPROM is the recommended method for using the S_CLK at 125 MHz to create a 3.125 Gbps link baud rate because the EEPROM boot load accesses the required configuration registers before the SerDes are released from reset. This can be performed by modifying the EEPROM loading script (for more information, see “EEPROM Scripts” in the *Tsi578 User Manual*).

Once the boot load is complete, the modified switch ports operate at 3.125 Gbps, while the remaining ports operate at 2.5 Gbps.

Using the Script

The example EEPROM loading script in the “EEPROM Scripts” appendix of the *Tsi578 User Manual* configures ports six and eight of the Tsi578. Other ports can be added to the script and configured by editing the text. The script is written assuming that no other contents are required in the EEPROM. Additional register configurations may be appended to the script as required, as well as the value written to location 0 of the EEPROM to indicate the number (hex) of registers the bootloader is required to initialize. For more information regarding configuring the contents of the EEPROM, see “I2C Interface” in the *Tsi578 User Manual*.

A.1.1.2 Modification by Maintenance Transaction

Modification by maintenance transactions must occur after the link to the host processor tasked with changing the port speeds has initialized. The process involves performing the sequence of operations listed in “[Example Maintenance Transaction Sequence](#)” on page 73.



The possibility of link instability exists should the process not be followed in the stated sequence

Example Maintenance Transaction Sequence

The following procedure configures port two. After these steps are complete, port two can train with its link partner at a baud rate of 3.125Gbps.

1. Reset the MAC by asserting `SOFT_RST_x4` and leave the `IO_SPEED` set to 3.125
 - Write offset `0x132C8` with `0x7FFF0012`
2. Set the `BYPASS_INIT` bit to enable control of the following: `MPLL_CK_OFF`, `SERDES_RESET`, `MPLL_PWRON`, `TX_EN`, `RX_PLL_PWRON`, `RX_EN`
 - Write offset `0x132C0` with `0xCA060084`
3. Clear the `RX_EN` bit in the `SMAC_x SerDes Configuration Register Channel 0 - 3`
 - Write offset `0x132B0` with `0x203CA513`
 - Write offset `0x132B4` with `0x203CA513`
 - Write offset `0x132B8` with `0x203CA513`
 - Write offset `0x132BC` with `0x203CA513`
4. Clear the `RX_PLL_PWRON` bit in the `SMAC_x SerDes Configuration Register Channel 0 - 3`
 - Write offset `0x132B0` with `0x203C2513`
 - Write offset `0x132B4` with `0x203C2513`
 - Write offset `0x132B8` with `0x203C2513`
 - Write offset `0x132BC` with `0x203C2513`
5. Clear the `TX_EN` field in the `SMACx_CFG_CH0`
 - Write offset `0x132B0` with `0x200C2513`
 - Write offset `0x132B4` with `0x200C2513`

-
- Write offset 0x132B8 with 0x200C2513
 - Write offset 0x132BC with 0x200C2513
 - 6. Clear the MPLL_PWRON bit in the SMACx_CFG_GLOBAL register
 - Write offset 0x132c0 with 0xCA060004
 - Ensure that BYPASS_INIT remains asserted
 - 7. Set the MPLL_CK_OFF bit in the SMACx_CFG_GLOBAL register
 - Write offset 0x132c0 with 0xCA060044
 - 8. Change the multipliers by:
 - Write offset 0x132C4 with 0x002C0545
 - Write offset 0x132C0 with 0xCA060045
 - 9. Clear the MPLL_CK_OFF bit in the SMACx_CFG_GBL register
 - Write offset 0x132C0 with 0xCA060005
 - 10. Toggle the SERDES_RSTN bit in the SMACx_CFG_GBL register
 - Write offset 0x132C0 with 0x4A060005
 - Write offset 0x132c0 with 0xCA060005
 - 11. Set the MPLL_PWRON bit in the SMACx_CFG_GLOBAL register
 - Write offset 0x132C0 with 0xCA060085
 - Ensure that BYPASS_INIT remains asserted
 - 12. Set TX_EN[2:0] to 0b011 in the SMACx_CFG_CH0-3 register
 - Write offset 0x132B0 with 0x203C2513
 - Write offset 0x132B4 with 0x203C2513
 - Write offset 0x132B8 with 0x203C2513
 - Write offset 0x132BC with 0x203C2513
 - 13. Set the RX_PLL_PWRON bit in the SMACx_CFG_CH0-3 register
 - Write offset 0x132B0 with 0x203CA513
 - Write offset 0x132B4 with 0x203CA513
 - Write offset 0x132B8 with 0x203CA513
 - Write offset 0x132BC with 0x203CA513
 - 14. Set the RX_EN bit in the SMACx_CFG_CH0-3 register
 - Write offset 0x132B0 with 0x203CE513
 - Write offset 0x132B4 with 0x203CE513
 - Write offset 0x132B8 with 0x203CE513
 - Write offset 0x132BC with 0x203CE513

15. Release the MAC from reset
 - Write offset 0x132c8 with 0x7FFF0002

A.2 P_CLK Programming

The Tsi578 recommends a P_CLK operating frequency of 100 MHz. However, the device also supports P_CLK frequencies less than the recommended 100 MHz. The ability to support other P_CLK frequencies gives the Tsi578 flexibility in both application support and design.



The minimum frequency supported by the P_CLK input is 25 MHz. Operation above 100 MHz or below 25 MHz is not tested or guaranteed.

The following sections describe the effects on the Tsi578 when the input frequency of the P_CLK source is decreased from the recommended 100 MHz operating frequency.

A.2.1 RapidIO Specifications Directly Affected by Changes in the P_CLK Frequency

The following sections describe how changing the P_CLK frequency to below the recommended 100 MHz operation affect the counters and state machines in the Tsi578 that are defined in the *RapidIO Interconnect Specification (Revision 1.3)*.

A.2.1.1 Port Link Time-out CSR

RapidIO Part 6: 1x/4x LP-Serial Physical Layer Specification Revision 1.3: Section 6.6.2.2 Port Link Time-out CSR (Block Offset 0x20)

The *RapidIO Interconnect Specification (Revision 1.3)* defines the Port Link Time-out CSR as follows:

The [port-link](#) time-out control register contains the time-out timer value for all ports on a device. This time-out is for link events, such as sending a packet to receiving the corresponding acknowledge and sending a link-request to receiving the corresponding link-response. The reset value is the maximum time-out interval, and represents between three and six seconds.

IDT Implementation

The Tsi578 supports this timer in the RapidIO Switch Port Link Time Out Control CSR. Effects of changing the P_CLK frequency are shown in the following formula:

- Time-out = $32/F \times TVAL$
 - F is P_CLK frequency in MHz
 - TVAL is the 24-bit counter setting
 - Maximum TVAL decimal value of 16,777,215 (0xFFFFF)

Effects of changing the P_CLK frequency and TVAL setting can be seen in [Table 22](#).

Table 22: Timer Values with P_CLK and TVAL Variations

P_CLK Setting	TVAL Setting	Equation	Timer Value
25 MHz	2,343,750 (0x23C346)	$32/25 \times 2,343,750$	3 seconds
25 MHz	4,687,500 (0x47868C)	$32/25 \times 4,687,500$	6 seconds
50 MHz	4,687,500 (0x47868C)	$32/50 \times 4,687,500$	3 seconds
50 MHz	9,375,000 (0x8F0D18)	$32/50 \times 9,375,000$	6 seconds
50 MHz	16,777,215 (0xFFFFF)	$32/50 \times 16,777,215$	10.4 seconds
100 MHz	9,375,000 (0x8F0D18)	$32/100 \times 9,375,000$	3 seconds
100 MHz	16,777,215 (0xFFFFF)	$32/100 \times 16,777,215$	5.4 seconds

A.2.1.2 *RapidIO Part 6: 1x/4x LP-Serial Physical Layer Specification Revision 1.3: Section 4.7.3.2 State Machine Variables and Functions*

SILENCE_TIMER_DONE

The *RapidIO Interconnect Specification (Revision 1.3)* defines the SILENCE_TIMER_DONE as follows:

Asserted when the SILENCE_TIMER_EN has been continuously asserted for 120 +/- 40 μ s and the state machine is in the SILENT state. The assertion of SILENCE_TIMER_DONE causes SILENCE_TIMER_EN to be de-asserted. When the state machine is not in the SILENT state, SILENCE_TIMER_DONE is de-asserted

IDT Implementation

The Tsi578's silence timer does not have user programmable registers. The silence timer is sourced from the P_CLK and any changes to P_CLK are directly reflected in the timer timeout period.

DISCOVERY_TIMER_DONE

The *RapidIO Interconnect Specification (Revision 1.3)* defines the `DISCOVERY_TIMER_DONE` as follows:

Asserted when `DISCOVERY_TIMER_EN` has been continuously asserted for 12 +/- 4msec and the state machine is in the `DISCOVERY` state. The assertion of `DISCOVERY_TIMER_DONE` causes `DISCOVERY_TIMER_EN` to be de-asserted. When the state machine is not in the `DISCOVERY` state, `DISCOVERY_TIMER_DONE` is de-asserted.

IDT Implementation

The Tsi578's discovery timer is programmed in the RapidIO Port x Discovery Timer. The `DISCOVERY_TIMER` field is used by serial ports configured to operate in 4x mode. The `DISCOVERY_TIMER` allows time for the link partner to enter its discovery state, and if the link partner supports 4x mode, for all four lanes to be aligned.



The `DISCOVERY_TIMER` field is a 4-bit field whose value is used as a pre-scaler for a 17-bit counter clocked by `P_CLK`.

The `DISCOVERY_TIMER` has a default value of 9 decimal, but can be programmed to various values. The results of changing the `DISCOVERY_TIMER` value and `P_CLK` are shown in [Table 23](#).

Table 23: Timer Values with `DISCOVERY_TIMER` and `P_CLK` Variations

P_CLK Setting	DISCOVERY_TIMER Setting	Equation	Timer Value
100 MHz	9 decimal	$9 * 0x1FFFF * 1 / P_CLK$	11.79 mS
100 MHz	9 decimal	$9 * 131071 * 1 / P_CLK$	11.79 mS
25 MHz	1 decimal	$1 * 131071 * 1 / 25 \text{ MHz}$	5.24 mS
25 MHz	2 decimal	$2 * 131071 * 1 / 25 \text{ MHz}$	10.48 mS
25 MHz	15 decimal	$15 * 131071 * 1 / 25 \text{ MHz}$	78.6 mS
50 MHz	1 decimal	$1 * 131071 * 1 / 50 \text{ MHz}$	2.62 mS
50 MHz	5 decimal	$5 * 131071 * 1 / 50 \text{ MHz}$	13.1 mS
50 MHz	15 decimal	$15 * 131071 * 1 / 50 \text{ MHz}$	19.7 mS
100 MHz	1 decimal	$1 * 131071 * 1 / 100 \text{ MHz}$	1.31 mS
100 MHz	9 decimal	$9 * 131071 * 1 / 100 \text{ MHz}$	11.79 mS
100 MHz	15 decimal	$15 * 131071 * 1 / 100 \text{ MHz}$	19.7 mS

A.2.2 IDT Specific Timers

The following sections describe how changing the P_CLK frequency to below the recommended 100 MHz operation affect the IDT-specific counters and state machines in the Tsi578.

A.2.2.1 Dead Link Timer

The Dead Link Timer period is controlled by the DLT_THRESH field in the SRIO MAC x Digital Loopback and Clock Selection Register.

Each time a silence is detected on a link, the counter is reloaded from this register and starts to count down. When the count reaches 0, the link is declared dead, which means that all packets are flushed from the transmit queue and no new packets are admitted to the queue until the link comes up.

The duration of the dead link timer is computed by the following formula:

- $2^{13} * DLT_THRESH * P_CLK \text{ period}$
 - P_CLK is 100 MHz (which gives a P_CLK period of 10nS)
 - Default value of DLT_THRESH is 0x7FFF (which corresponds to 32767)
- Using these parameters, the populated formula is $8192 * 32767 * 10e-9 = 2.68 \text{ seconds}$

When enabled, this timer is used to determine when a link is powered up and enabled, but dead (that is, there is no link partner responding). When a link is declared dead, the transmitting port on the Tsi578 removes all packets from its transmit queue and ensure that all new packets sent to port are dropped rather than placed in the transmit queue.

The DLT_THRESH is a 15-bit counter with a maximum value of 32767. [Table 24](#) shows equations using different values for DLT_THRESH and P_CLK.

Table 24: Timer Values with P_CLK and DLT_THRESH Variations

P_CLK Setting	Equation	Timer Value
25 MHz	$8192 * 1 * 1/25 \text{ MHz}$	327 uS
	$8192 * 32767 * 1/25 \text{ MHz}$	10.74 seconds
50 MHz	$8192 * 1 * 1/50 \text{ MHz}$	163.8 uS
	$8192 * 32767 * 1/50 \text{ MHz}$	5.37 seconds
100 MHz	$8192 * 1 * 1/100 \text{ MHz}$	81.9 uS
	$8192 * 32767 * 1/100 \text{ MHz}$	2.68 seconds

A.2.3 I²C interface and Timers

The I²C interface clock is derived from the P_CLK. Decreasing the frequency of P_CLK causes a proportional decrease in the I²C serial clock and affects the I²C timers. The timer values can be re-programmed during boot loading but the changes does not take effect until after the boot load has completed. As a result, a decrease from 100 MHz to 50 MHz of P_CLK causes a doubling of the boot load time of the EEPROM. Once boot loading has completed, the new values take effect and the I²C interface can operate at the optimum rate of the attached devices.

A.2.3.1 I²C Time Period Divider Register

The I2C Time Period Divider Register provides programmable extension of the reference clock period into longer periods used by the timeout and idle detect timers.

USDIV Period Divider for Micro-Second Based Timers

The USDIV field divides the reference clock down for use by the Idle Detect Timer, the Byte Timeout Timer, the I2C_SCLK Low Timeout Timer, and the Milli-Second Period Divider.

- $\text{Period(USDIV)} = \text{Period(P_CLK)} * (\text{USDIV} + 1)$
- P_CLK is 10 ns
- Tsi578 reset value is 0x0063

MSDIV Period Divider for Milli-Second Based Timers

The MSDIV field divides the USDIV period down further for use by the Arbitration Timeout Timer, the Transaction Timeout Timer, and the Boot/Diagnostic Timeout Timer.

- $\text{Period (MSDIV)} = \text{Period(USDIV)} * (\text{MSDIV} + 1)$
- Tsi578 reset value is 0x03E7

A.2.3.2 I2C Start Condition Setup/Hold Timing Register

The I2C Start Condition Setup/Hold Timing Register programs the setup and hold timing for the start condition when generated by the master control logic. The timer periods are relative to the reference clock.

This register is shadowed during boot loading, and can be reprogrammed prior to a chain operation without affecting the bus timing for the current EEPROM.

START_SETUP Count for the START Condition Setup Period

The START_SETUP field defines the minimum setup time for the START condition; that is, both I2C_SCLK and I2C_SD seen high prior to I2C_SD pulled low. This is a master-only timing parameter.



This value also doubles as the effective Stop Hold time.

- $\text{Period}(\text{START_SETUP}) = (\text{START_SETUP} * \text{Period}(\text{PCLK}))$
 - PCLK is 10ns
 - Reset time is 4.71 microseconds.
 - Tsi578 reset value is 0x01D7

START_HOLD Count for the START Condition Hold Period

The START_HOLD field defines the minimum hold time for the START condition; that is, from I2C_SD seen low to I2C_SCLK pulled low. This is a master only timing parameter.

- $\text{Period}(\text{START_HOLD}) = (\text{START_HOLD} * \text{Period}(\text{P_CLK}))$
- P_CLK is 10 ns
- Reset time is 4.01 microseconds
- Tsi578 reset value is 0x0191

A.2.3.3 I2C Stop/Idle Timing Register

The I2C Stop/Idle Timing Register programs the setup timing for the Stop condition when generated by the master control logic and the Idle Detect timer.



The START_SETUP time doubles as the Stop Hold.

The Stop/Idle register is broken down as follows:

- The timer period for the STOP_SETUP is relative to the reference clock
- The timer period for the Idle Detect is relative to the USDIV period
- The STOP_SETUP time is shadowed during boot loading, and can be reprogrammed prior to a chain operation without affecting the bus timing for the current EEPROM.

STOP_SETUP Count for STOP Condition Setup Period

The STOP_SETUP field defines the minimum setup time for the STOP condition (that is, both I2C_SCLK seen high and I2C_SD seen low prior to I2C_SD released high). This is a master-only timing parameter.

- $\text{Period}(\text{STOP_SETUP}) = (\text{STOP_SETUP} * \text{Period}(\text{P_CLK}))$
 - P_CLK is 10ns
 - Reset time is 4.01 microseconds
 - Tsi578 reset value is 0x0191

IDLE_DET Count for Idle Detect Period

The IDLE_DET field is used in two cases. First, it defines the period after reset during which the I2C_SCLK signal must be seen high in order to call the bus idle. This period is needed to avoid interfering with an ongoing transaction after reset. Second, it defines the period before a master transaction during which the I2C_SCLK and I2C_SD signals must both be seen high in order to call the bus idle.

This period is a protection against external master devices not correctly idling the bus.

- $\text{Period}(\text{IDLE_DET}) = (\text{IDLE_DET} * \text{Period}(\text{USDIV}))$, where USDIV is the microsecond time defined in the I2C Time Period Divider Register



A value of zero results in no idle detect period, meaning the bus will be sensed as idle immediately.

- Reset time is 51 microseconds
- Tsi578 reset value is 0x0033

A.2.3.4 I2C_SD Setup and Hold Timing Register

The I2C_SD Setup and Hold Timing Register programs the setup and hold times for the I2C_SD signal when output by either the master or slave interface. It is shadowed during boot loading, and can be reprogrammed prior to a chain operation without affecting the bus timing for the current EEPROM.

SDA_SETUP Count for the I2C_SD Setup Period

The SDA_SETUP field defines the minimum setup time for the I2C_SD signal; that is, I2C_SD is set to a desired value prior to rising edge of I2C_SCLK. This applies to both slave and master interface.



This value should be set to the sum of the I2C_SD setup time and the maximum rise/fall time of the I2C_SD signal in order to ensure that the signal is valid on the output at the correct time. This time is different than the raw I2C_SD setup time in the *I²C Specification*.

- $\text{Period}(\text{SDA_SETUP}) = (\text{SDA_SETUP} * \text{Period}(\text{P_CLK}))$, where P_CLK is 10ns.
 - Reset time is 1260 nanoseconds
 - Tsi578 reset value is 0x007E

SDA_HOLD Count for I2C_SD Hold Period

The SDA_HOLD field defines the minimum hold time for the I2C_SD signal; that is, I2C_SD valid past the falling edge of I2C_SCLK. This applies to both slave and master interface.

- $\text{Period}(\text{SDA_HOLD}) = (\text{SDA_HOLD} * \text{Period}(\text{P_CLK}))$, where P_CLK is 10 ns.
 - Reset time is 310 nanoseconds
 - Tsi578 reset value is 0x001F

A.2.3.5 I2C_SCLK High and Low Timing Register

The I2C_SCLK High and Low Timing Register programs the nominal high and low periods of the I2C_SCLK signal when generated by the master interface.

It is shadowed during boot loading, and can be reprogrammed prior to a chain operation without affecting the bus timing for the current EEPROM.

SCL_HIGH Count for I2C_SCLK High Period

The SCL_HIGH field defines the nominal high period of the clock, from rising edge to falling edge of I2C_SCLK. This is a master-only parameter.

The actual observed period may be shorter if other devices pull the clock low.

- $\text{Period}(\text{SCL_HIGH}) = (\text{SCL_HIGH} * \text{Period}(\text{P_CLK}))$
 - P_CLK is 10 ns
 - Reset time is 5.00 microseconds (100 kHz)
 - Tsi578 reset value is 0x01F4

SCL_LOW Count for I2C_SCLK Low Period

The SCL_LOW field defines the nominal low period of the clock, from falling edge to rising edge of I2C_SCLK. This is a master-only parameter.

The actual observed period may be longer if other devices pull the clock low.

- $\text{Period}(\text{SCL_LOW}) = (\text{SCL_LOW} * \text{Period}(\text{P_CLK}))$
 - P_CLK is 10 ns
 - Reset time is 5.00 microseconds (100 kHz)
 - Tsi578 reset value is 0x01F4

A.2.3.6 I2C_SCLK Minimum High and Low Timing Register

The I2C_SCLK Minimum High and Low Timing Register programs the minimum high and low periods of the I2C_SCLK signal when generated by the master interface. It is shadowed during boot loading, and can be reprogrammed prior to a chain operation without affecting the bus timing for the current EEPROM.

SCL_MINH Count for I2C_SCLK High Minimum Period

The SCL_MINH field defines the minimum high period of the clock, from rising edge seen high to falling edge of I2C_SCLK. This is a master-only parameter.

The actual observed period may be shorter if other devices pull the clock low.

- $\text{Period}(\text{SCL_MINH}) = (\text{SCL_MINH} * \text{Period}(\text{P_CLK}))$
 - P_CLK is 10 ns
 - Reset time is 4.01 microseconds
 - Tsi578 reset value is 0x0191

SCL_MINL Count for I2C_SCLK Low Minimum Period

The SCL_MINL defines the minimum low period of the clock, from falling edge seen low to rising edge of I2C_SCLK. This is a master-only parameter.

The actual observed period may be longer if other devices pull the clock low.

- $\text{Period}(\text{SCL_MINL}) = (\text{SCL_MINL} * \text{Period}(\text{P_CLK}))$
 - P_CLK is 10 ns
 - Reset time is 4.71 microseconds
 - Tsi578 reset value is 0x01D7

A.2.3.7 I2C_SCLK Low and Arbitration Timeout Register

The I2C_SCLK Low and Arbitration Timeout Register programs the I2C_SCLK low timeout and the Arbitration timeout. The arbitration timer period is relative to the MSDIV period, and the I2C_SCLK low timeout period is relative to the USDIV period.

SCL_TO Count for I2C_SCLK Low Timeout Period

The SCL_TO field defines the maximum amount of time for a slave device holding the I2C_SCLK signal low. This timeout covers the period from I2C_SCLK falling edge to the next I2C_SCLK rising edge. A value of 0 disables the timeout.

- $\text{Period}(\text{SCL_TO}) = (\text{SCL_TO} * \text{Period}(\text{USDIV}))$
 - USDIV is the microsecond time defined in the I2C Time Period Divider Register.
 - The reset value of this timeout is 26 milliseconds
 - Tsi578 reset value is 0x65BB

ARB_TO Count for Arbitration Timeout Period

The ARB_TO field defines the maximum amount of time for the master interface to arbitrate for the bus before aborting the transaction. This timeout covers the period from master operation start (see setting the START bit in the I2C Master Control Register) until the ACK/NACK is received from the external slave for the slave device address. A value of 0 disables the timeout.

- $\text{Period}(\text{ARB_TO}) = (\text{ARB_TO} * \text{Period}(\text{MSDIV}))$
 - MSDIV is the millisecond time defined in I2C Time Period Divider Register.
 - The reset value of this timeout is 51 milliseconds
 - This timeout is not active during the boot load sequence.
 - Tsi578 reset value is 0x0033

A.2.3.8 I2C Byte/Transaction Timeout Register

The I2C Byte/Transaction Timeout Register programs the Transaction and Byte time-outs. The timer periods are relative to the USDIV period for the byte timeout, and relative to the MSDIV period for the transaction timeout.

BYTE_TO Count for Byte Timeout Period

The BYTE_TO field defines the maximum amount of time for a byte to be transferred on the I²C bus. This covers the period from Start condition to next ACK/NACK, between two successive ACK/NACK bits, or from ACK/NACK to Stop/Restart condition. A value of 0 disables the timeout.

- $\text{Period}(\text{BYTE_TO}) = (\text{BYTE_TO} * \text{Period}(\text{USDIV}))$
 - USDIV is the microsecond time defined in I2C Time Period Divider Register.
 - This timeout is disabled on reset, and is not used during boot load.
 - Tsi578 reset value is 0x0000

TRAN_TO Count for Transaction Timeout Period

The TRAN_TO field defines the maximum amount of time for a transaction on the I2C bus. This covers the period from Start to Stop. A value of 0 disables the timeout.

- $\text{Period}(\text{TRAN_TO}) = (\text{TRAN_TO} * \text{Period}(\text{MSDIV}))$
 - MSDIV is the millisecond time defined in I2C Time Period Divider Register.
 - This timeout is disabled on reset, and is not used during boot load
 - Tsi578 reset value is 0x0000

A.2.3.9 I2C Boot and Diagnostic Timer

The I2C Boot and Diagnostic Timer programs a timer used to timeout the boot load sequence, and can be used after boot load as a general purpose timer.

COUNT Count for Timer Period

The COUNT field defines the period for the timer. The initial reset value is used for overall boot load timeout. A value of 0 disables the timeout.



During normal operation, this timer can be used for any general purpose timing.

The timer begins counting when this register is written. If this register is written while the counter is running, the timer is immediately restarted with the new COUNT, and the DTIMER/BLTO event is not generated.

When the timer expires, either the BLTO or DTIMER event is generated, depending on whether the boot load sequence is active. If FREERUN is set to 1 when timer expires, then the timer is restarted immediately (the event is still generated), providing a periodic interrupt capability.

- $\text{Period}(\text{DTIMER}) = (\text{COUNT} * \text{Period}(\text{MSDIV}))$
 - MSDIV is the millisecond period define in I2C Time PeriodDivider Register.
 - The reset value for the boot load timeout is four seconds. If the boot load completes before the timer expires, the timer is set to zero (disabled).
 - Tsi578 reset value is 0x0FA0

A.2.4 Other Performance Factors

This section describes any other factors that may impact the performance of the Tsi578 if P-CLK is programmed to operate lower than the recommended 100 MHz frequency.

A.2.4.1 Internal Register Bus Operation

The internal register bus, where all the internal registers reside, is a synchronous bus clocked by the P_CLK source. A decrease in the P_CLK frequency causes a proportional increase in register access time during RapidIO maintenance transactions, JTAG registers accesses, and I²C register accesses.

RapidIO Maintenance Transaction

Maintenance transactions use the internal register bus to read and write registers in the Tsi578. If the P_CLK frequency is decreased, it may be necessary to review the end point's response latency timer value to ensure that it does not expire before the response is returned.



Changing the frequency of the P_CLK does not affect the operation or performance of the RapidIO portion of the switch, in particular its ability to route or multicast packets between ports.

JTAG Register Interface

Changing the P_CLK frequency affects accesses to the internal registers through the JTAG register interface because the interface uses the internal register bus. However, the decreased performance will not be noticeable.

Boundary scan operations are not affected by a change in the P_CLK frequency because these transactions use the JTAG TCK clock signal and do not access the internal register bus.

B. Ordering Information

This chapter discusses ordering information and describes the part numbering system for the Tsi578.

B.1 Ordering Information

Table 25: Ordering Information

Part Number	Temperature Grade	Package Type	Pb (Lead) Free
TSI578-10GCL	Commercial	FCBGA	No; Leaded Balls and Bumps
TSI578-10GCLH	Commercial	FCBGA	No; Leaded Balls
TSI578-10GCLY	Commercial	FCBGA	No; RoHS Compliant
TSI578-10GCLV	Commercial	FCBGA	Yes
TSI578-10GIL	Industrial	FCBGA	No; Leaded Balls and Bumps
TSI578-10GILH	Industrial	FCBGA	No; Leaded Balls
TSI578-10GILY	Industrial	FCBGA	No; RoHS Compliant
TSI578-10GILV	Industrial	FCBGA	Yes



Corporate Headquarters

6024 Silver Creek Valley Road
San Jose, CA 95138 USA
www.IDT.com

Sales

1-800-345-7015 or 408-284-8200
Fax: 408-284-2775
www.IDT.com/go/sales

Tech Support

www.idt.com/support

DISCLAIMER Integrated Device Technology, Inc. (IDT) reserves the right to modify the products and/or specifications described herein at any time, without notice, at IDT's sole discretion. Performance specifications and operating parameters of the described products are determined in an independent state and are not guaranteed to perform the same way when installed in customer products. The information contained herein is provided without representation or warranty of any kind, whether express or implied, including, but not limited to, the suitability of IDT's products for any particular purpose, an implied warranty of merchantability, or non-infringement of the intellectual property rights of others. This document is presented only as a guide and does not convey any license under intellectual property rights of IDT or any third parties.

IDT's products are not intended for use in applications involving extreme environmental conditions or in life support systems or similar devices where the failure or malfunction of an IDT product can be reasonably expected to significantly affect the health or safety of users. Anyone using an IDT product in such a manner does so at their own risk, absent an express, written agreement by IDT.

Integrated Device Technology, IDT and the IDT logo are trademarks or registered trademarks of IDT and its subsidiaries in the United States and other countries. Other trademarks used herein are the property of IDT or their respective third party owners.

Copyright ©2016 Integrated Device Technology . All rights reserved.