

Wideband RF LDMOS Integrated Power Amplifier 40 W, 1800 – 2000 MHz

Description

The PTMA180402EL and PTMA180402FL are matched, wideband 40-watt, 2-stage, LDMOS integrated amplifiers intended for use in all typical modulation formats from 1800 to 2000 MHz. These devices are offered in thermally-enhanced ceramic packages for cool and reliable operation.

PTMA180402EL
Package H-33265-8

PTMA180402FL
Package H-34265-8

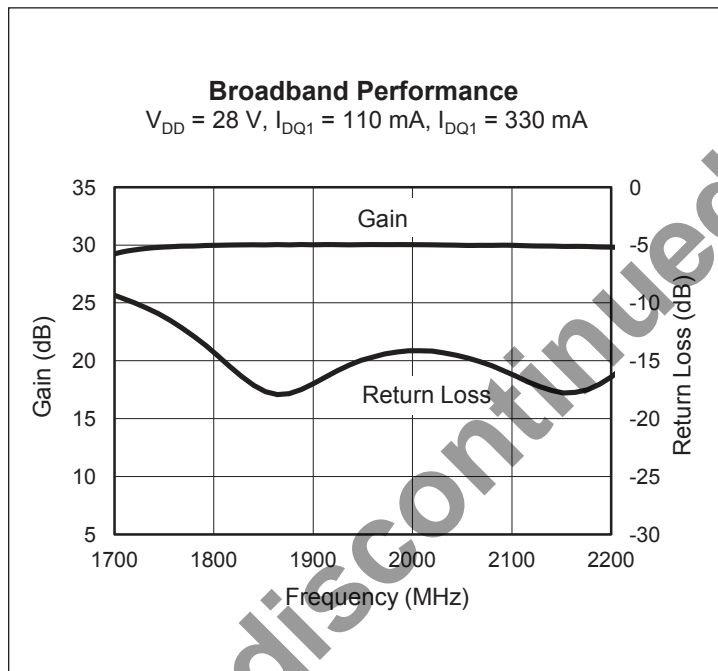
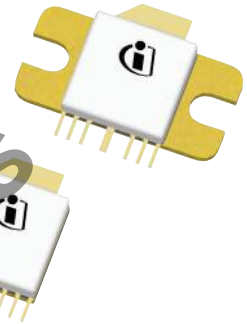

Features

- Designed for wide RF and modulation bandwidths and low memory effects
- On-chip matching, integrated input DC block, 50-ohm input and > 5-ohm output
- Typical single-carrier CDMA performance at 1960 MHz, 28 V
 - Average output power = 4 W
 - Linear gain = 30 dB
 - Efficiency = 14%
 - Adjacent channel power = -53 dBc
- Typical 2-tone performance, 1960 MHz, 28 V
 - Output power (PEP) = 50 W at IM3 = -30 dBc
 - Efficiency = 33%
- Capable of handling 10:1 VSWR @ 28 V, 40 W (CW) output power
- Integrated ESD protection. Meets HBM Class 1B (minimum), per JESD22-A114F
- High-performance, thermally-enhanced packages, Pb-free and RoHS compliant, with solder-friendly plating

All published data at $T_{CASE} = 25^{\circ}\text{C}$ unless otherwise indicated

ESD: Electrostatic discharge sensitive device—observe handling precautions!

RF Characteristics

CDMA Measurements (tested in Infineon test fixture)

$V_{DD} = 28\text{ V}$, $I_{DQ1} = 110\text{ mA}$, $I_{DQ2} = 335\text{ mA}$, $P_{OUT} = 4\text{ W}$ average, $f = 1960\text{ MHz}$

Characteristic	Symbol	Min	Typ	Max	Unit
Gain	G_{ps}	28.5	30	—	dB
Drain Efficiency	η_D	13	14	—	%
Adjacent Channel Power Ratio	ACPR	—	-53	-50	dBc

DC Characteristics

Stage 1 Characteristics	Conditions	Symbol	Min	Typ	Max	Unit
Drain Leakage Current	$V_{DS} = 28\text{ V}$, $V_{GS} = 0\text{ V}$	I_{DSS}	—	—	1.0	μA
	$V_{DS} = 63\text{ V}$, $V_{GS} = 0\text{ V}$	I_{DSS}	—	—	10.0	μA
Gate Leakage Current	$V_{GS} = 10\text{ V}$, $V_{DS} = 0\text{ V}$	I_{GSS}	—	—	1.0	μA
On-state Resistance	$V_{GS} = 10\text{ V}$, $V_{DS} = 0.1\text{ V}$	$R_{DS(on)}$	—	1.6	—	Ω
Operating Gate Voltage	$V_{DS} = 28\text{ V}$, $I_{DQ} = 160\text{ mA}$	V_{GS}	2.0	2.5	3.0	V
Stage 2 Characteristics	Conditions	Symbol	Min	Typ	Max	Unit
Drain-source Breakdown Voltage	$V_{GS} = 0\text{ V}$, $I_{DS} = 10\text{ mA}$	$V_{(BR)DSS}$	65	—	—	V
Drain Leakage Current	$V_{DS} = 28\text{ V}$, $V_{GS} = 0\text{ V}$	I_{DSS}	—	—	1.0	μA
	$V_{DS} = 63\text{ V}$, $V_{GS} = 0\text{ V}$	I_{DSS}	—	—	10.0	μA
Gate Leakage Current	$V_{GS} = 10\text{ V}$, $V_{DS} = 0\text{ V}$	I_{GSS}	—	—	1.0	μA
On-state Resistance	$V_{GS} = 10\text{ V}$, $V_{DS} = 0.1\text{ V}$	$R_{DS(on)}$	—	0.21	—	Ω
Operating Gate Voltage	$V_{DS} = 28\text{ V}$, $I_{DQ} = 330\text{ mA}$	V_{GS}	2.0	2.5	3.0	V

Maximum Ratings

Parameter	Symbol	Value	Unit
Drain-Source Voltage	V_{DSS}	65	V
Gate-Source Voltage	V_{GS}	-0.5 to +12	V
Operating Voltage	V_{DD}	24 to 28	V
Junction Temperature	T_J	200	°C
Storage Temperature Range	T_{STG}	-40 to +150	°C
Overall Thermal Resistance ($T_{CASE} = 70^{\circ}C$) $P_{OUT} = 40\text{ W}$, $I_{DQ1} = 160\text{ mA}$, $I_{DQ2} = 330\text{ mA}$	1st Stage	$R_{\theta JC}$	5.0 °C/W
	2nd Stage	$R_{\theta JC}$	1.1 °C/W

Ordering Information

Type and Version	Package Type	Package Description	Shipping
PTMA180402EL V1	H-33265-8	Themally-enhanced, slotted flange	Tray
PTMA180402EL V1 R50	H-33265-8	Themally-enhanced, slotted flange	Tape
PTMA180402FL V1	H-34265-8	Themally-enhanced, earless flange	Tray
PTMA180402FL V1 R50	H-34265-8	Themally-enhanced, earless flange	Tape

Typical Performance (data taken in a production test fixture)

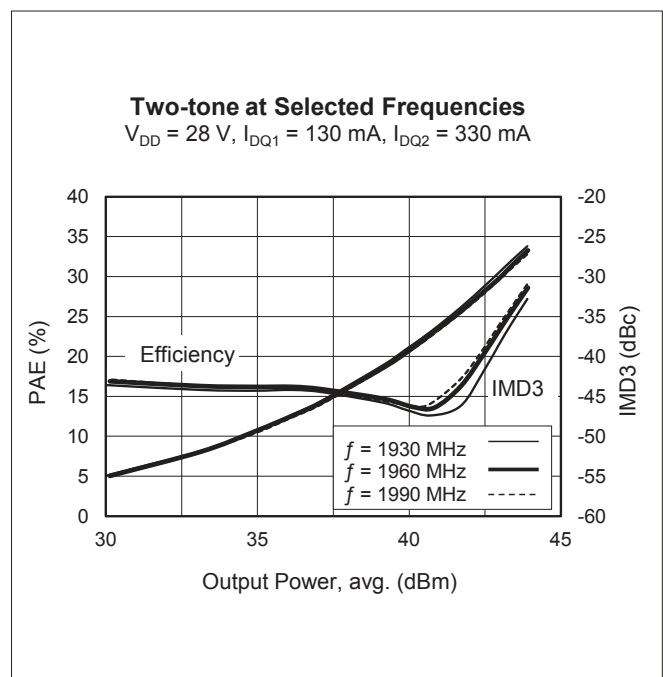
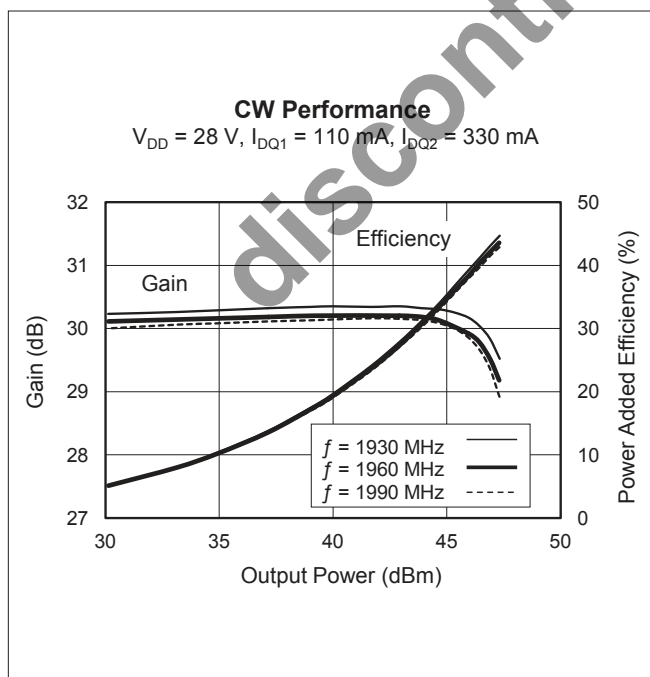

Typical Performance (cont.)

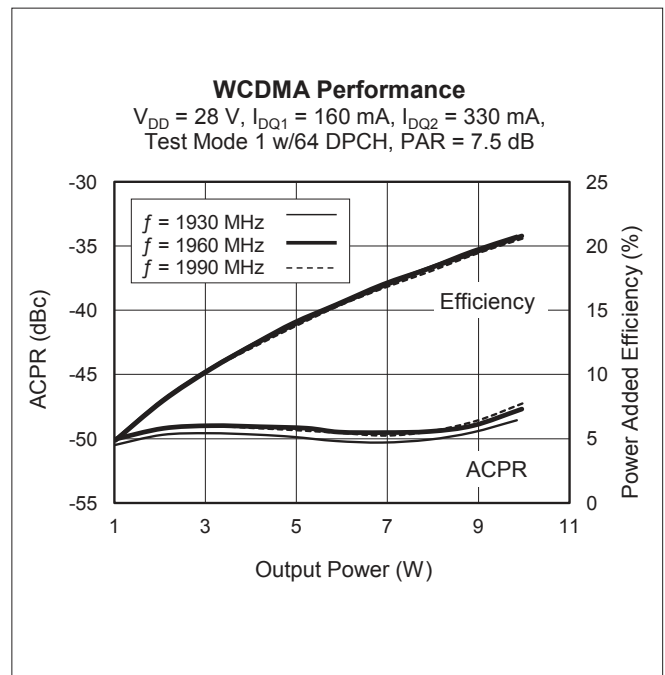
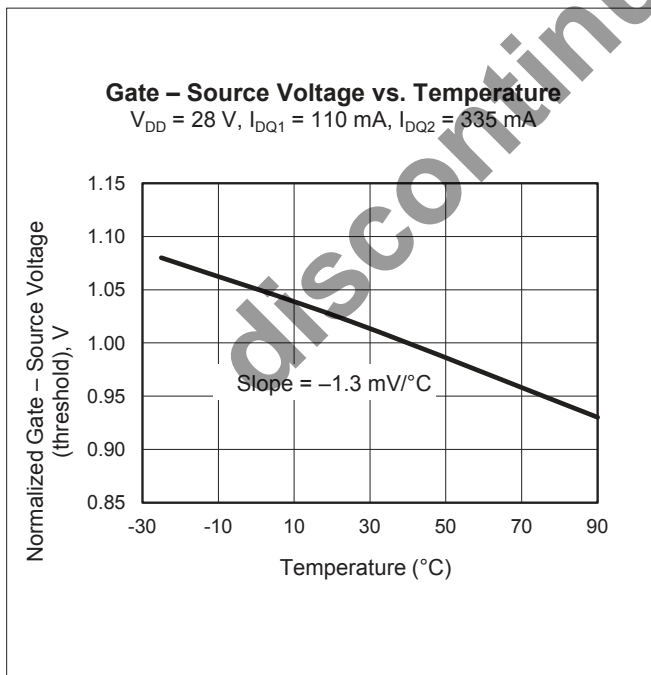
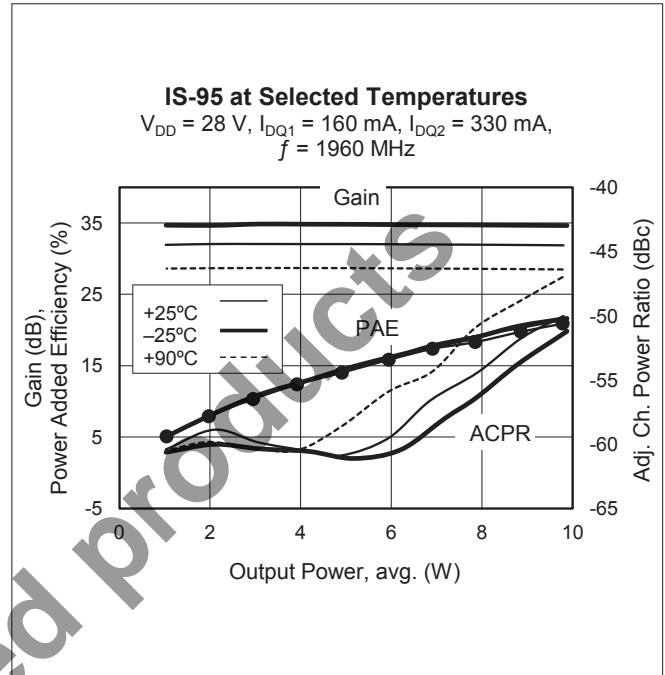
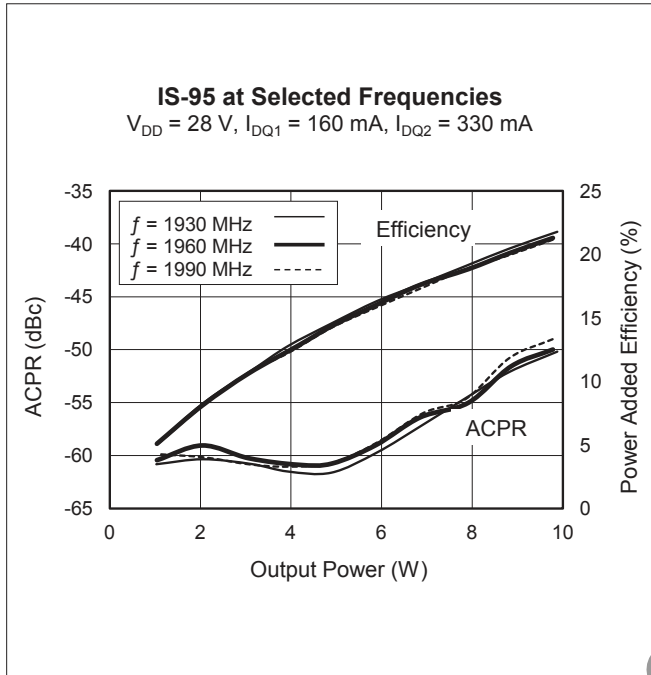

Typical Performance (cont.)

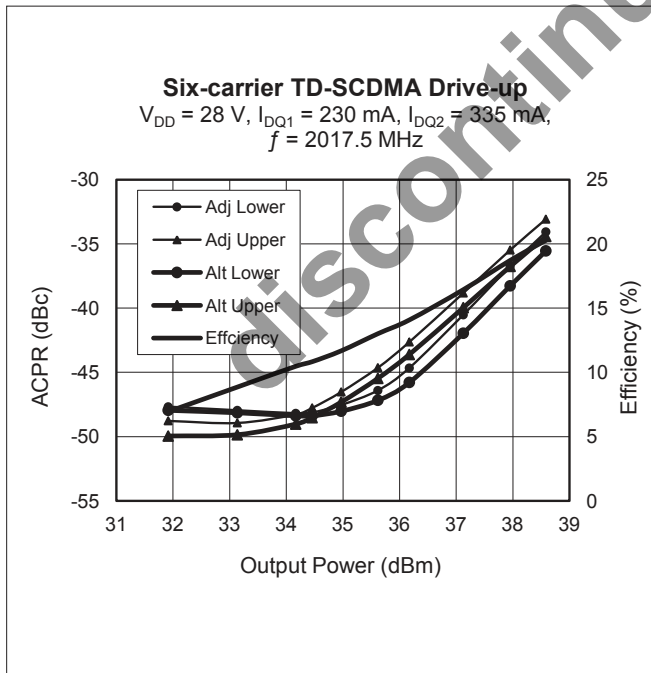
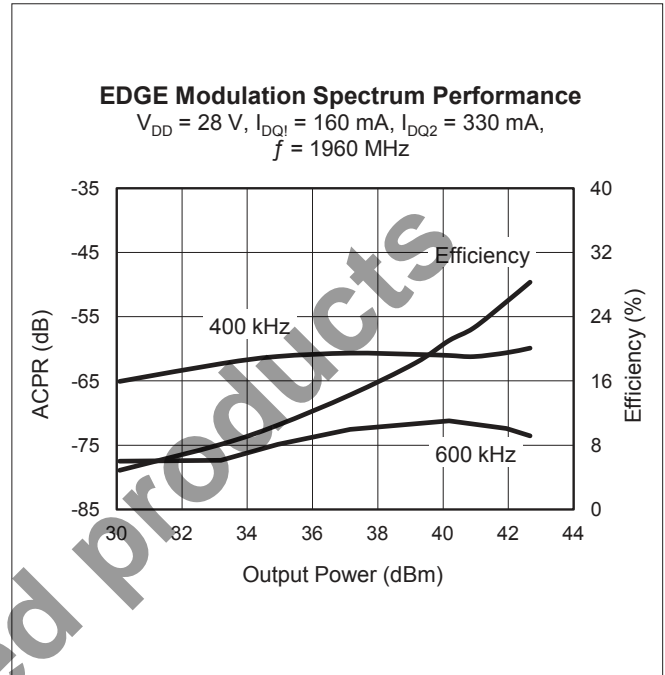
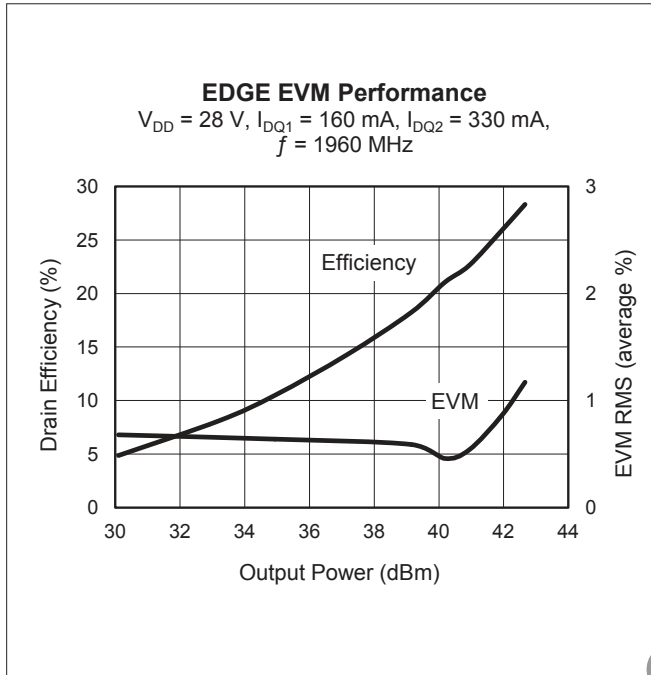

Broadband Circuit Impedance

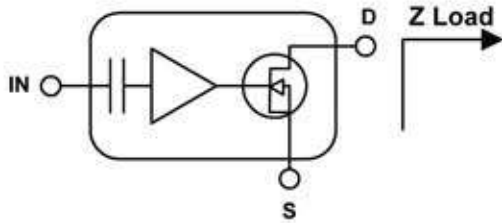

Frequency MHz	Z Load Ω	
	R	jX
1700	8.89	-3.62
1800	7.27	-2.99
1900	6.26	-2.13
2000	5.59	-1.19
2100	5.14	-0.27
2200	4.89	0.67

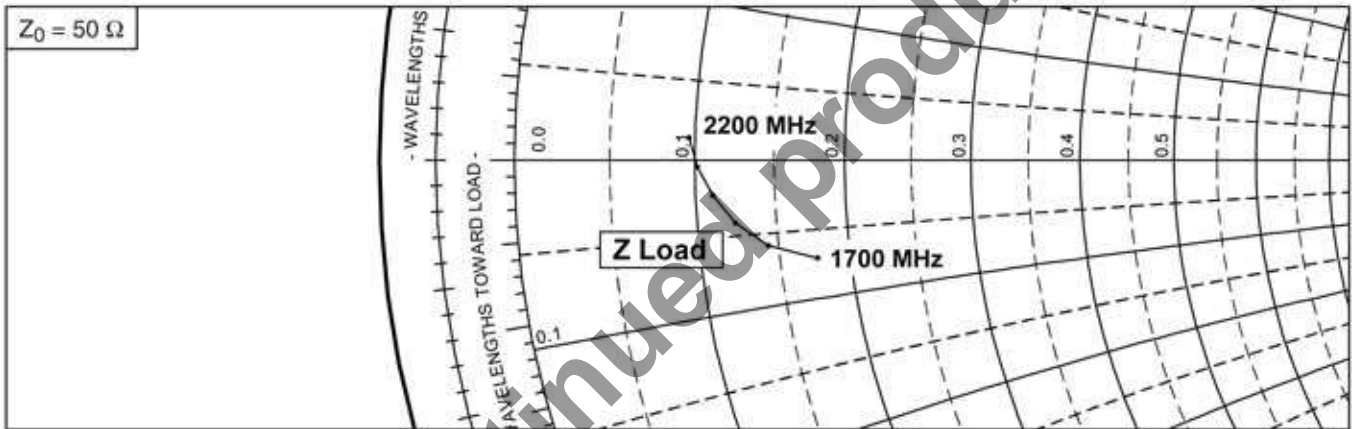

Reference Circuit

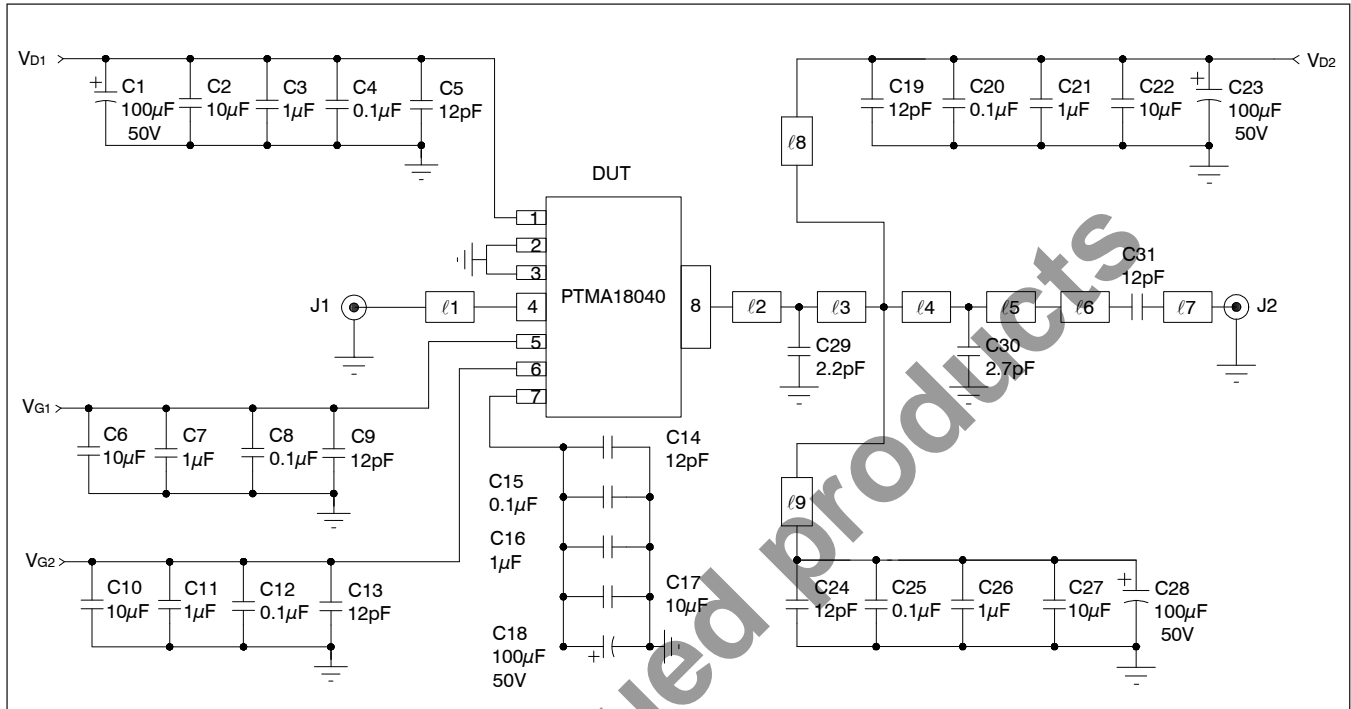

Reference circuit schematic for $f = 1930 - 1990$ MHz

Circuit Assembly Specifications

DUT	PTMA180402EL or PTMA180402FL	LDMOS Integrated Power Amplifier
Test Fixture Part No.	LTN/PTMA180402EFL	
PCB	Rogers 4350, 0.76 mm [.030"] thick, 1 oz. copper, $\epsilon_r = 3.48$	
Find Gerber files for this test fixture on the Infineon Web site at http://www.infineon.com/rfpower		

Microstrip	Electrical Characteristics at 1960 MHz	Dimensions: L x W (mm)	Dimensions: L x W (in.)
l1	0.224λ , 49.8 Ω	20.75 x 1.70	0.817 x 0.067
l2	0.022λ , 10.4 Ω	1.85 x 13.00	0.073 x 0.512
l3	0.027λ , 10.4 Ω	2.26 x 13.00	0.089 x 0.512
l4	0.035λ , 34.1 Ω	3.18 x 3.00	0.125 x 0.118
l5	0.048λ , 34.1 Ω	4.29 x 3.00	0.169 x 0.118
l6	0.153λ , 44.5 Ω	14.07 x 2.03	0.554 x 0.080
l7	0.046λ , 49.8 Ω	4.27 x 1.70	0.168 x 0.067
l8, l9	0.136λ , 61.1 Ω	12.83 x 1.19	0.505 x 0.047

Reference Circuit (cont.)

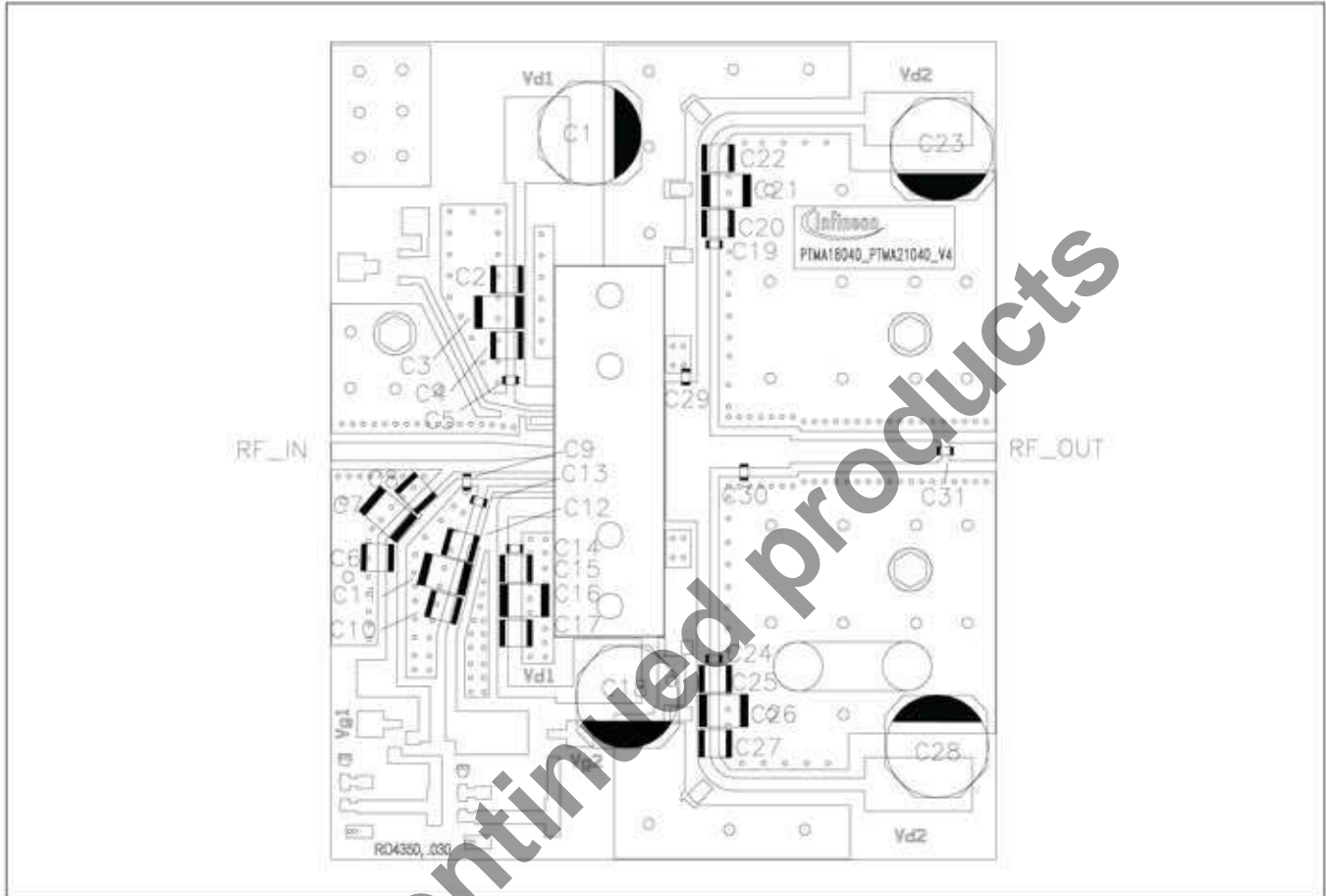

Reference circuit assembly diagram* (not to scale)

Component	Description	Suggested Manufacturer	P/N or Comment
C1, C18, C23, C28	Electrolytic capacitor, 100 μ F, 50 V	Panasonic Electronic Components	EEV-FK1H101GP
C2, C6, C10, C17, C22, C27	Ceramic capacitor, 10 μ F	Murata	GRM422Y5V106Z050AL
C3, C7, C11, C16, C21, C26	Ceramic capacitor, 1 μ F	TDK Corporation	C4532X7R2A105M230KA
C4, C8, C12, C15, C20, C25	Capacitor, 0.1 μ F	Kemet	C1210C104K5RACTU
C5, C9, C13, C14, C19, C24, C31	Ceramic capacitor, 12 pF	ATC	600S120JT
C29	Ceramic capacitor, 2.2 pF	ATC	600S2R2CT
C30	Ceramic capacitor, 2.7 pF	ATC	600S2R7BT

Pinout Diagram

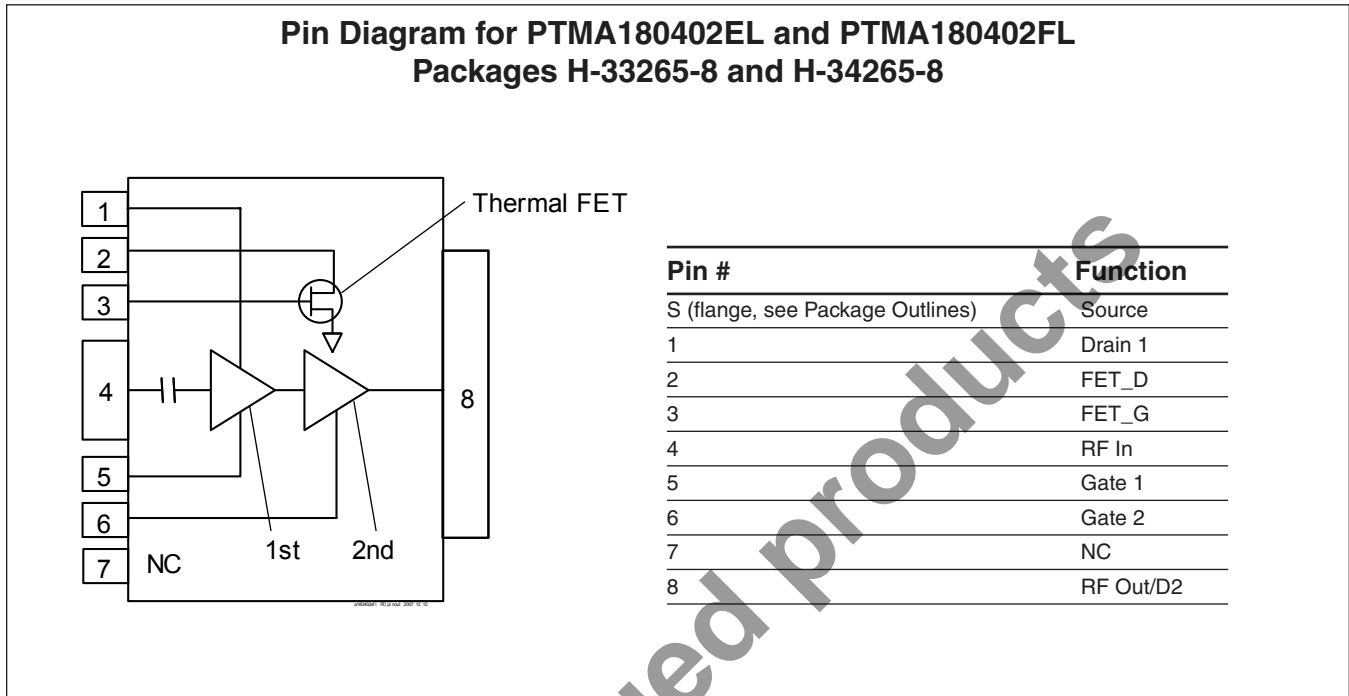

Find the latest and most complete information about products and packaging at the Infineon Internet page <http://www.infineon.com/rfpower>

discontinued products

Revision History: 2015-01-14

Data Sheet

Previous Version: 2013-07-30, Data Sheet

Page	Subjects (major changes since last revision)
All	Products Discontinued. Please see PD Notes : PD_215-14

We Listen to Your Comments

Any information within this document that you feel is wrong, unclear or missing at all? Your feedback will help us to continuously improve the quality of this document. Please send your proposal (including a reference to this document) to:

highpowerRF@infineon.com

To request other information, contact us at:
+1 877 465 3667 (1-877-GO-LDMOS) USA
or +1 408 776 0600 International

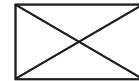

Discontinued products

Edition 2015-01-14

**Published by
Infineon Technologies AG
81726 Munich, Germany**

**© 2011 Infineon Technologies AG
All Rights Reserved.**

Legal Disclaimer

The information given in this document shall in no event be regarded as a guarantee of conditions or characteristics. With respect to any examples or hints given herein, any typical values stated herein and/or any information regarding the application of the device, Infineon Technologies hereby disclaims any and all warranties and liabilities of any kind, including without limitation, warranties of non-infringement of intellectual property rights of any third party.

Information

For further information on technology, delivery terms and conditions and prices, please contact the nearest Infineon Technologies Office (www.infineon.com/rfpower).

Warnings

Due to technical requirements, components may contain dangerous substances. For information on the types in question, please contact the nearest Infineon Technologies Office.

Infineon Technologies components may be used in life-support devices or systems only with the express written approval of Infineon Technologies, if a failure of such components can reasonably be expected to cause the failure of that life-support device or system or to affect the safety or effectiveness of that device or system. Life support devices or systems are intended to be implanted in the human body or to support and/or maintain and sustain and/or protect human life. If they fail, it is reasonable to assume that the health of the user or other persons may be endangered.