

THIS DRAWING IS UNPUBLISHED. RELEASED FOR PUBLICATION
 © COPYRIGHT - By - ALL RIGHTS RESERVED.

LOC		DIST		REVISIONS			
P	LTR	DESCRIPTION		DATE	DWN	APVD	
AF	50	B		REVISED PER ECR-13-007151	30JUL2013	KH	KR

- 1 FITS 0.81±0.025 X 6.35 [.032±.001 X .250] TAB REFER TO CP-14251 FOR DETAILS.
- 2 WIRE SIZE: 1.3-2.0MM² [16-14 AWG], STRANDED ONLY. STRIP LENGTH 7.14 [.281]
- 3 INSULATION SIZE: 4.70 [.185] MAX DIA.
- 4 CONTINUOUS STRIP, SPLICE FREE.

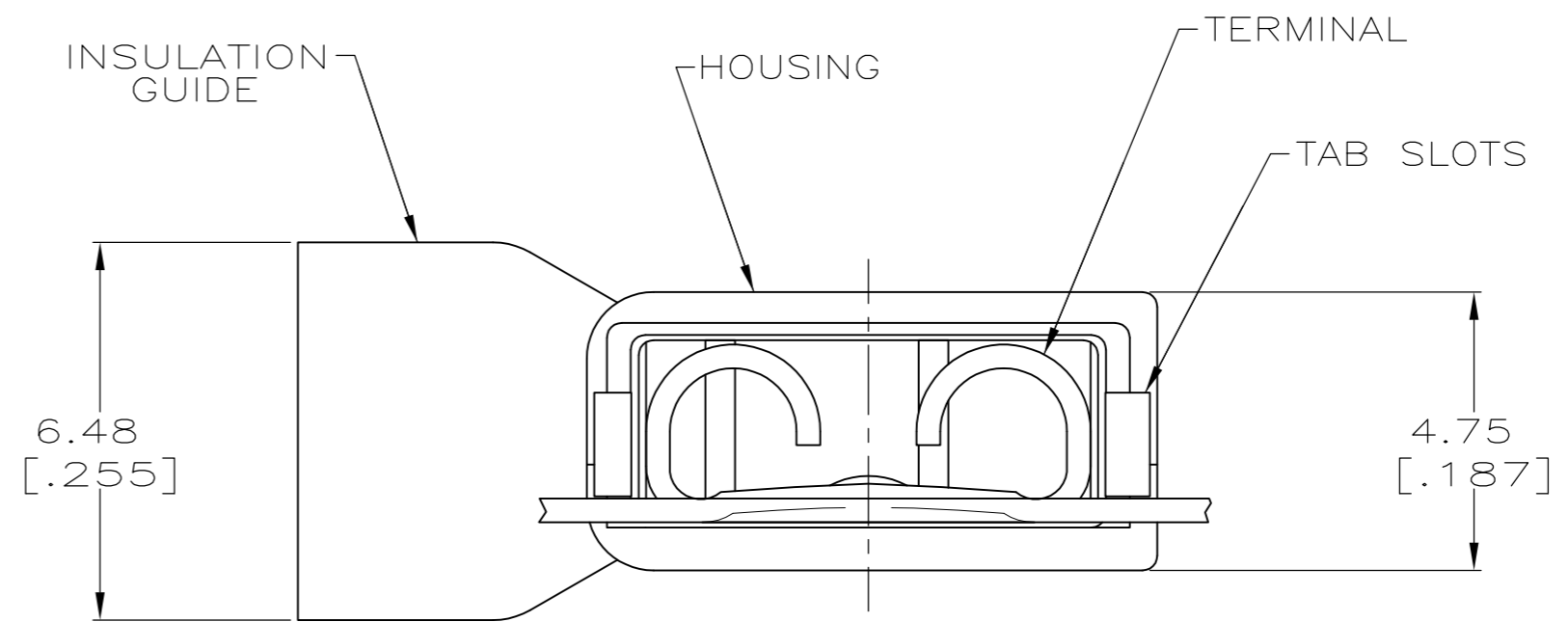
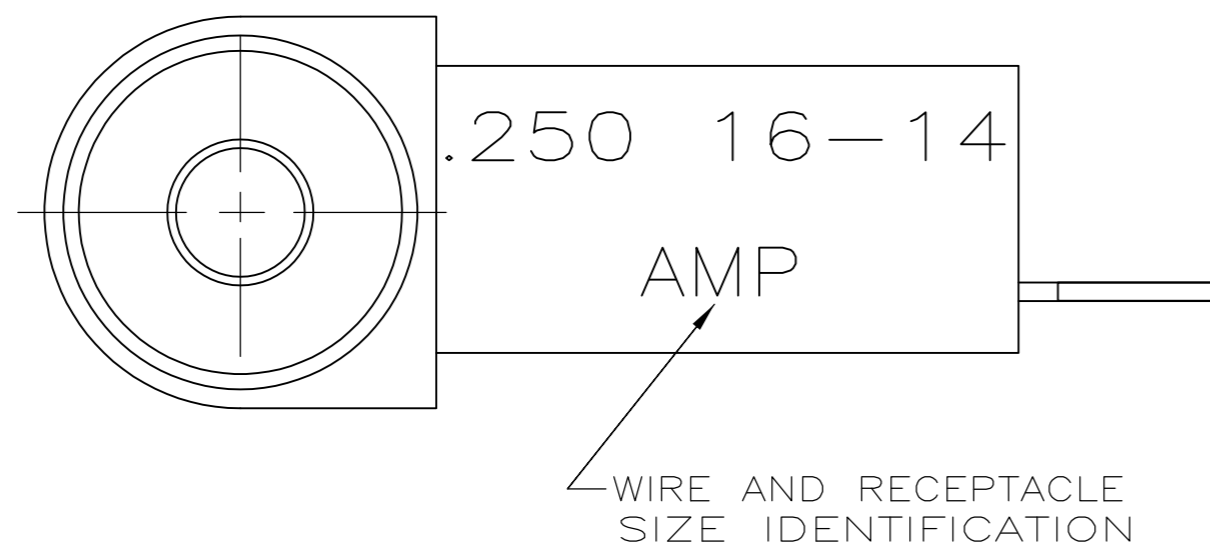
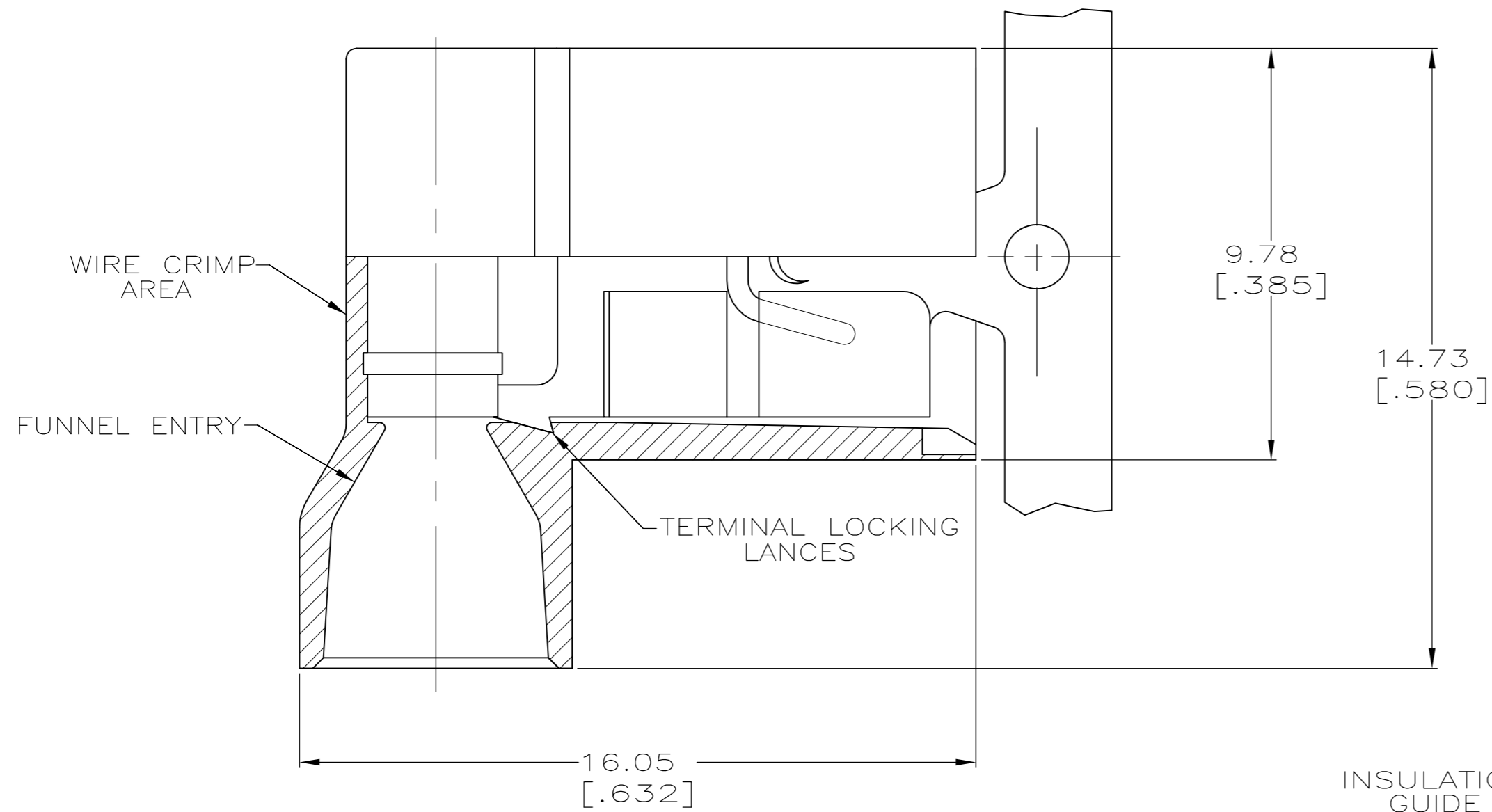

TYPE 6/6 NYLON	BLUE TRANSLUCENT	BRASS	TIN	3-521127-2
MATERIAL	COLOR	MATERIAL	FINISH	PART NUMBER
HOUSING		TERMINAL		

THIS DRAWING IS A CONTROLLED DOCUMENT.		DWN	JR RUTH	11/4/96	 TE Connectivity
DIMENSIONS: mm [INCHES]		CHK	MS FEHER	11/4/96	
TOLERANCES UNLESS OTHERWISE SPECIFIED:		APVD	J WORMAN	11/4/96	
0 PLC ± - 1 PLC ± - 2 PLC ± - 3 PLC ± 0.25 [.010] 4 PLC ± - ANGLES ± -		PRODUCT SPEC	108-2043	NAME	
MATERIAL	SEE TABLE	FINISH	SEE TABLE	WEIGHT	-
CUSTOMER DRAWING		SCALE	10:1	SHEET	1 OF 1
		REV	B		