

This document is the property of Amphenol Corporation and is delivered on the express condition that is not to be disclosed, reproduced or used, in whole or in part, for manufacture or sale by anyone other than Amphenol Corporation without its prior consent, and that no right is granted to disclose or to use any information in this document.

The marking on this product doesn't contain environmental hazardous materials per Material Specification SS-00259 for Sony GP compliant or per directive 2011/65/EU for RoHS compliant.



ORIGINAL



REVISIONS				
SYM	ECN No.	DESCRIPTION	DATE	APPROVED
A		RELEASE FOR RoHS	02/23/2006	Armstrong Kao
B	NE-06194	ADDING THE CRITICAL DIMENSION MARKS	07/06/2006	Armstrong Kao
C	NE-06227	CHANGED MATTE TIN PLATED ON CONTACT	07/31/2006	Edward Wu
D	NE-11005	DRAWING UPDATE	01/12/2011	Arron Lin
E	NE-11034	REDEFINE COLORS	03/15/2011	Arron Lin
F	NE-11040	UPDATE MATERIAL OPTION	03/23/2011	Arron Lin
A1	NE-11074	MODIFY SHELL KINK DIMENSION	05/26/2011	Arron Lin
B1	NE-11124	MODIFY DRAWING	09/09/2011	Arron Lin
C1	NE-14131	ADDED 15u" GOLD OPTIONS	07/11/2014	Arron Lin
D1	NE-15137	ADD DIM & TAIL 2.00 OPTION & D/C	04/18/2016	Arron Lin

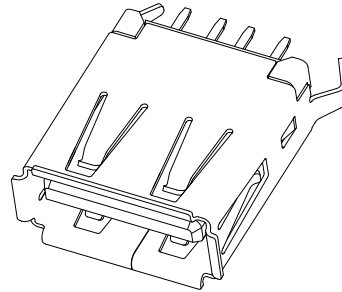
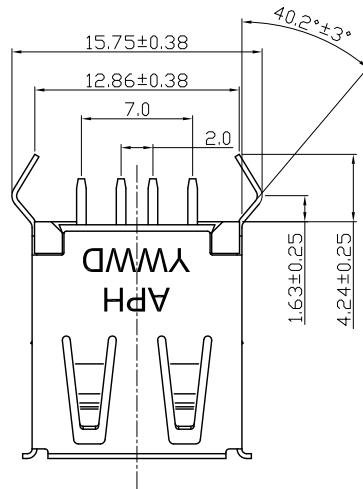

NOTES:

- MATERIAL:
HOUSING: HIGH TEMPERATURE THERMAL PLASTIC HTN (HALOGEN FREE),
BOTTOM COVER: HIGH TEMPERATURE THERMAL PLASTIC HTN, UL94V-0, COLOR: OPTIONS.
TERMINAL: PHOSPHOR BRONZE.
SHELL: BRASS.
- FINISH:
TERMINAL:
CONTACT AREA: SELECTED GOLD PLATING;
SOLDERING AREA: TIN PLATING 100 U" THICKNESS MIN.;
UNDER PLATING: NICKEL PLATING 50 U" THICKNESS MIN. OVERALL.
SHELL:
NICKEL PLATING 50 U" THICKNESS MIN. OVERALL.
- PACKING IS PER AMTA PACKING SPECIFICATION PKS-0001.
- THIS PRODUCT DOESN'T CONTAIN ENVIRONMENTAL HAZARDOUS PER DIRECTIVE 2011/65/EU FOR RoHS COMPLIANT.
- PRODUCT SPECIFICATION REFER TO : PS-7329

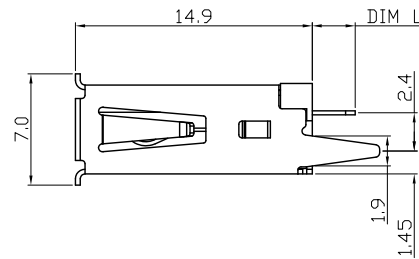
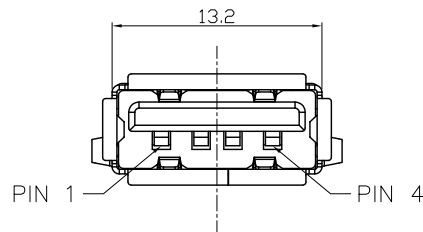

PART NO: GSB111XXKEU

- CONTACT FINISH
- 1 : FLASH GOLD
 - 2 : 30u" GOLD
 - 5 : 15u" GOLD

- COLOR / DIM L
- 0 : IVORY /2.7mm
 - 1 : BLACK /2.7mm
 - 2 : IVORY /2.0mm
 - 3 : BLACK /2.0mm

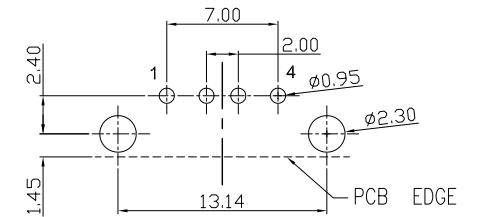

RECOMMENDED PCB LAYOUT TOP VIEW

PCB THICKNESS: 1.60±0.05mm

TOLERANCE: ±0.05mm

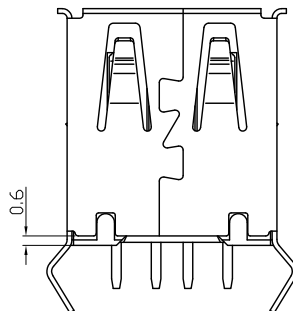

TOLERANCE	APPROVALS	DATE	TITLE	Amphenol® Amphenol Corporation Amphenol Taiwan Corporation			
X. X.X ±0.30 X.XX ±0.20 X.XXX ±0.10	DRAWN Debby Hung	04/18/2016	UNIVERSAL SERIAL BUS RECEPTACLE, SERIES A STANDARD, STRAIGHT PCB MOUNT	UNIT mm		SIZE A3	PART No. GSB111XXKEU
ANGULAR ±1°	CHECKED Roger Tsai	04/18/2016		SCALE NA		SHEET 1 OF 2	DWG No. GSB111XXKEU
UNLESS OTHERWISE SPECIFIED	APPROVED Arron Lin	04/18/2016		PROJECT CODE OTHER		REV. D1	

This document is the property of Amphenol Corporation and is delivered on the express condition that is not to be disclosed, reproduced or used, in whole or in part, for manufacture or sale by anyone other than Amphenol Corporation without its prior consent, and that no right is granted to disclose or to use any information in this document.

The marking on this product doesn't contain environmental hazardous materials per Material Specification SS-00259 for Sony GP compliant or per directive 2011/65/EU for RoHS compliant.



ORIGINAL



		REVISIONS		
SYM	ECN No.	DESCRIPTION	DATE	APPROVED
A		RELEASE FOR RoHS	02/23/2006	Armstrong Kao
B	NE-06194	ADDING THE CRITICAL DIMENSION MARKS	07/06/2006	Armstrong Kao
C	NE-06227	CHANGED MATTE TIN PLATED ON CONTACT	07/31/2006	Edward Wu
D	NE-11005	DRAWING UPDATE	01/12/2011	Arron Lin
E	NE-11034	REDEFINE COLORS	03/15/2011	Arron Lin
F	NE-11040	UPDATE MATERIAL OPTION	03/23/2011	Arron Lin
A1	NE-11074	MODIFY SHELL KINK DIMENSION	05/26/2011	Arron Lin
B1	NE-11124	MODIFY DRAWING	09/09/2011	Arron Lin
C1	NE-14131	ADDED 15u" GOLD OPTIONS	07/11/2014	Arron Lin
D1	NE-15137	ADD DIM & TAIL 2.00 OPTION & D/C	04/18/2016	Arron Lin

29 PCS TRAY/CARTON

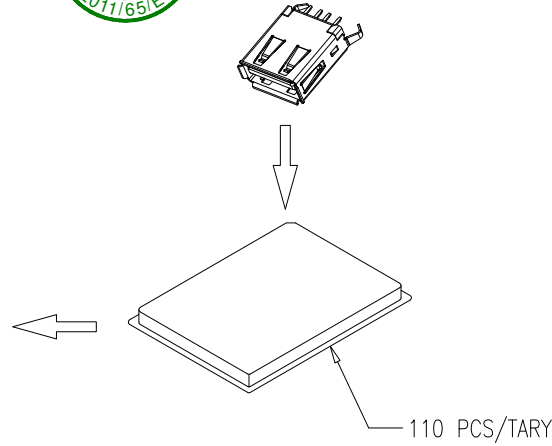
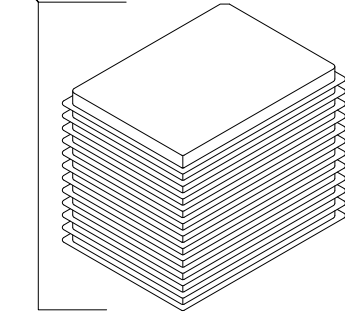

NOTES:

1. STAPLES SHOULD ONLY BE USED TO SET UP CARTON. ALL CARTON CLOSURES MUST BE DONE WITH TAPE.
2. FILL PACKAGING TRAYS WITH THE QUANTITIES AS INDICATED IN THE CHART.
3. SHIPPING CARTON DIMENSION: 520 X 273 X 310 MM.
4. TRAY SIZE: 230mm X 220mm X 10 mm

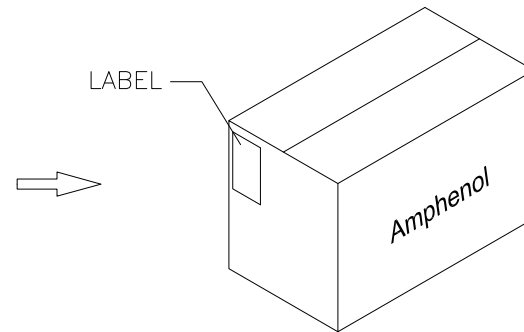
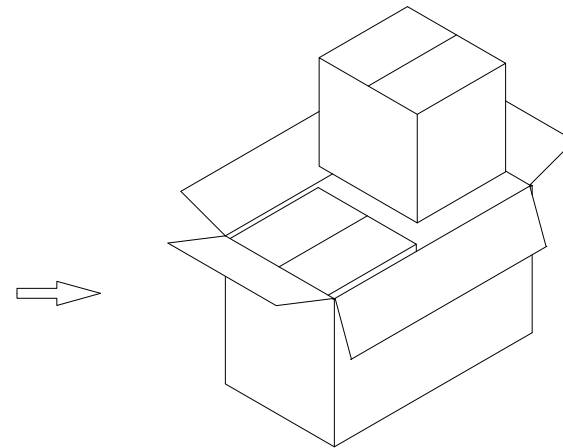
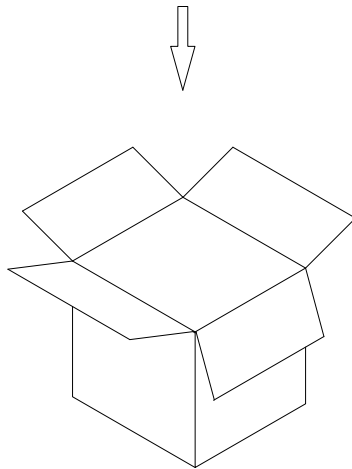

PACKAGING BY TRAY	14.8 G/W KG	13.3 N/W KG	110 PCS/TRAY	58 TRAY/CARTON	6380 QUANTITY (PCS)	GSB111XXKEU PART NUMBER
-------------------	-------------	-------------	--------------	----------------	---------------------	-------------------------

TOLERANCE	APPROVALS	DATE	TITLE		PART No.	
X. ±0.30	DRAWN Debby Hung	04/18/2016	USB , SERIES A UPRIGHT , RIGHT-ANGLE PCB MOUNT		Amphenol [®] Amphenol Corporation Amphenol Taiwan Corporation	
X.X ±0.20	CHECKED Roger Tsai	04/18/2016				
X.XX ±0.10	APPROVED Arron Lin	04/18/2016	UNIT mm	SIZE A3	GSB111XXKEU	
ANGULAR ±1°	DWG TYPE CUST DWG	PROJECT CODE OTHER	SCALE NA	SHEET 2 OF 2	DWG No. GSB111XXKEU	REV. D1
UNLESS OTHERWISE SPECIFIED						