

### Features

- 3.3V  $\pm$ 10% supply voltage
- 25MHz XTAL or reference clock input
- Five PCIe® 2.0 Compliant 100MHz selectable HCSL outputs with -0.5% spread
  - default is spread off
- Two 25MHz LVCMOS output
- Industrial temperature range: -40°C to 85°C
- Packaging (Pb free and Green)
  - TSSOP 28 (L)

### Description

The PI6C49015 is a high performance networking clock generator which generates PCIe 2.0 Compliant 100MHz HCSL clock signals along with two LVCMOS 25MHz clock from either 25MHz crystal or reference input. This integrated solution is ideal for Networking, Embedded systems and other systems that require PCIe 1.0 and 2.0 HCSL signals and 25MHz clocks yet small foot print.

### Applications

- Networking systems
- Embedded systems
- Other systems

### Block Diagram

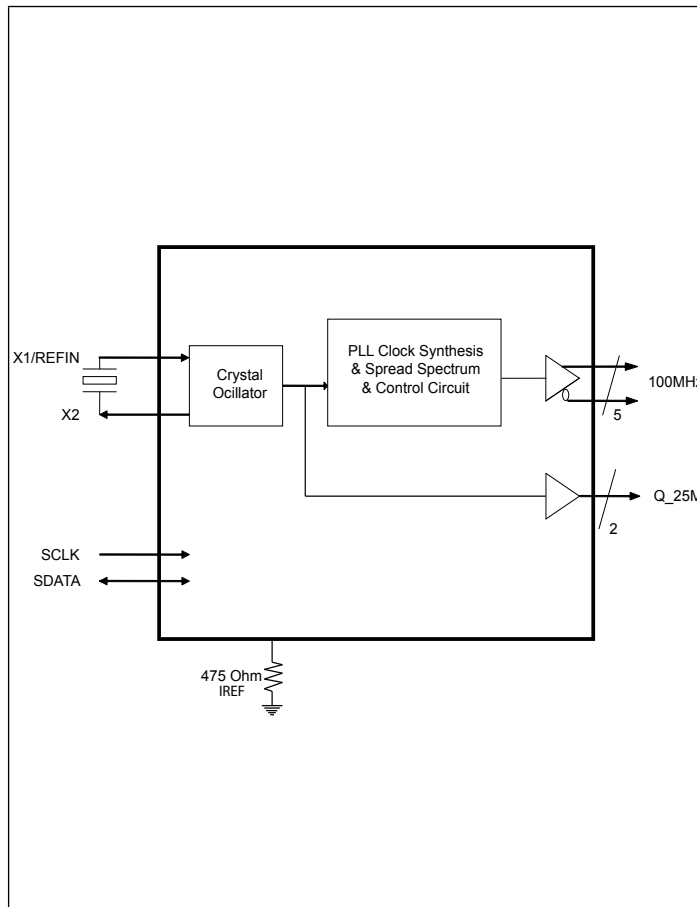

### Pin Configuration

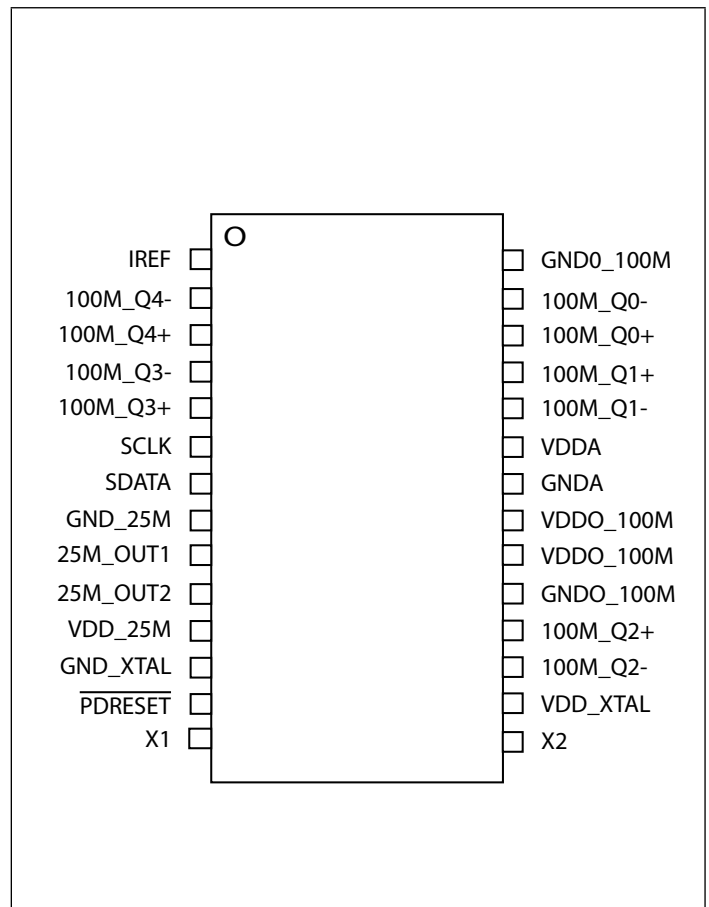

### Pin Description

Pin #	Pin Name	Pin Type	Pin Description
1	IREF	Output	Connect to 475-Ohm resistor to set HCSL output drive current
2	100M_Q4-	Output	100MHz HCSL output
3	100M_Q4+	Output	100MHz HCSL output
4	100M_Q3-	Output	100MHz HCSL output
5	100M_Q3+	Output	100MHz HCSL output
6	SCLK	Input	SMBus compatible input clock. Supports fast mode 400 kHz input clock
7	SDATA	I/O	SMBus compatible data line
8	GND_25M	Power	Ground for 25MHz output
9	25M_OUT1	Output	25MHz LVCMOS output. When disabled, output is trisated and has a normal 110kOhm pull-down
10	25M_OUT2	Output	25MHz LVCMOS output. When disabled, output is trisated and has a normal 110kOhm pull-down
11	VDD_25M	Power	3.3V supply for 25MHz output
12	GND_XTAL	Power	Ground for XTAL
13	$\overline{\text{PDRESET}}$	Input	Power on reset, when low all PLLs are powered down and output trisated. SMBus registers are reset to default values
14	X1	Input	Crystal input. Integrated 6pf capacitance
15	X2	Output	Crystal output. Integrated 6pf capacitance
16	VDD_XTAL	Power	3.3V supply for XTAL
17	100M_Q2-	Output	100MHz HCSL output
18	100M_Q2+	Output	100MHz HCSL output
19	GNDO_100M	Output	Ground for 100MHz output buffer
20	VDDO_100M	Power	3.3V supply for 100MHz output buffer
21	VDDO_100M	Power	3.3V supply for 100MHz output buffer
22	GNDA	Power	Ground for 100MHz related PLL
23	VDDA	Power	3.3V supply for 100MHz related PLL
24	100M_Q1-	Output	100MHz HCSL output
25	100M_Q1+	Output	100MHz HCSL output
26	100M_Q0+	Output	100MHz HCSL output
27	100M_Q0-	Output	100MHz HCSL output
28	GNDO_100M	Power	Ground for 100MHz output buffer

## Serial Data Interface (SMBus)

PI6C49015 is a slave only SMBus device that supports indexed block read and indexed block write protocol using a single 7-bit address and read/write bit as shown below.

### Address Assignment

A6	A5	A4	A3	A2	A1	A0	R/W
1	1	0	1	0	0	1	0/1

### How to Write

1 bit	8 bits	1	8 bits	1	8 bits	1	8 bits	1		8 bits	1	1 bit
Start bit	d2H	Ack	Register offset	Ack	Byte Count = N	Ack	Data Byte 0	Ack	...	Data Byte N - 1	Ack	Stop bit

Note:

1. Register offset for indicating the starting register for indexed block write and indexed block read. Byte Count in write mode cannot be 0.

### How to Read (M: abbreviation for Master or Controller; S: abbreviation for slave/clock)

1 bit	8 bits	1 bit	8 bits	1 bit	1 bit	8 bits	1 bit	8 bits	1 bit	8 bits	1 bit	...	8 bits	1 bit	1 bit
M: Start bit	M: Send "D2h"	S: sends Ack	M: send starting data-byte location: N	S: sends Ack	M: Start bit	M: Send "D3h"	S: sends Ack	S: sends # of data bytes that will be sent: X	M: sends Ack	S: sends starting data byte N	M: sends Ack	...	S: sends data byte N+X-1	M: Not Acknowledge	M: Stop bit

## Byte 0: Spread Spectrum Control Register

Bit	Description	Type	Power Up Condition	Output(s) Affected	Notes
7	Spread Spectrum Selection for 100 MHz HCSL PCI-Express clocks	RW	0	All 100MHz HCSL PCI Express output	0=spread off 1 = -0.5% down spread
6	Enables hardware or software control of OE bits (see Byte 0–Bit 6 and Bit 5 Functionality table)	RW	0	$\overline{\text{PD\_RESET}}$ pin, bit 5	0 = hardware cntl 1 = software ctrl
5	Software $\overline{\text{PD\_RESET}}$ bit. Enables or disables all outputs (see Byte 0–Bit 6 and Bit 5 Functionality table)	RW	1	All outputs	0 = disabled 1 = enabled
4 to 1	Reserved	RW	Undefined	Not Applicable	
0	OE for 25M_Out2	RW	1	25M_Out2	0 = disabled 1 = enabled

### Byte 0 - Bit 6 and Bit 5 Functionality

Bit 6	Bit 5	Description
0	X	$\overline{\text{PD\_RESET}}$ HW pin/signal = enabled
1	0	Disables all outputs and tri-states the outputs, $\overline{\text{PD\_RESET}}$ HW pin/signal = DO NOT CARE
1	1	Enable all outputs, $\overline{\text{PD\_RESET}}$ HW pin/signal = DON'T CARE

### Byte 1: Control Register

Bit	Description	Type	Power Up Condition	Output(s) Affected	Notes
7	Reserved	RW	Undefined	Not Applicable	
6	OE for 25M_Out1	RW	1	25M_Out1	0 = disabled 1 = enabled
5	Reserved	RW	Undefined	Not Applicable	
4	OE for 100M_Q4 HCSL output	RW	1	100M_Q4	0=disable 1 = enabled
3	Reserved	RW	Undefined	Not Applicable	
2	OE for 100M_Q3 HCSL output	RW	1	100M_Q3	0=disable 1 = enabled
1 to 0	Reserved	RW	Undefined	Not Applicable	

### Byte 2: Control Register

Bit	Description	Type	Power Up Condition	Output(s) Affected	Notes
7 to 5	Reserved	RW	Undefined	Not Applicable	
4 to 0	Reserved	R	Undefined	Not Applicable	

### Byte 3: Control Register

Bit	Description	Type	Power Up Condition	Output(s) Affected	Notes
7	OE for 100M_Q2 HCSL Output	RW	1	100M_Q2	0 = disabled 1 = enabled
6 to 3	Reserved	RW	Undefined	Not Applicable	
2	OE for 100M_Q1 HCSL Output	RW	1	100M_Q1	0 = disabled 1 = enabled
1	OE for 100M_Q0 HCSL Output	RW	1	100M_Q0	0 = disabled 1 = enabled
0	Reserved	R	Undefined	Not Applicable	

### Byte 4 & 5: Control Register

Bit	Description	Type	Power Up Condition	Output(s) Affected	Notes
7 to 0	Reserved	R	Undefined	Not Applicable	

### Byte 6: Control Register

Bit	Description	Type	Power Up Condition	Output(s) Affected	Notes
7	Revision ID bit 3	R	1	Not Applicable	
6	Revision ID bit 2	R	0	Not Applicable	
5	Revision ID bit 1	R	0	Not Applicable	
4	Revision ID bit 0	R	0	Not Applicable	
3	Vendor ID bit 3	R	0	Not Applicable	
2	Vendor ID bit 2	R	0	Not Applicable	
1	Vendor ID bit 1	R	1	Not Applicable	
0	Vendor ID bit 0	R	1	Not Applicable	

**Absolute Maximum Ratings<sup>1</sup>** (Over operating free-air temperature range)

Parameters	Min.	Max.	Units
Storage Temperature	-65	150	°C
Ambient Temperature with Power Applied	-40	85	
3.3V Analog Supply Voltage	-0.5	4.6	V
ESD Protection (HBM)		2000	

**Note:**

1. Stress beyond those listed under “Absolute Maximum Ratings” may cause permanent damage to the device.

**Recommended Operating Conditions**

Symbol	Parameters	Test Condition	Min.	Typ.	Max.	Units
V <sub>DD</sub>	Power supply		3.0	-	3.6	V
I <sub>DD</sub>	Total Power Supply Current	All outputs unloaded	-	-	65	mA
I <sub>DD_Output Tri-stated</sub>	Total power supply current with tri-stated outputs	OE = “0”, no load	-	-	42	mA
I <sub>DD Power-Down</sub>	Total power supply current in power down mode	PD_RESET= “0”, no load	-	-	3.8	mA
T <sub>A</sub>	Operating temperature		-40	-	+85	°C

**LVC MOS DC Electrical Characteristics**

Over Operating Conditions

Symbol	Parameter	Conditions	Min	Typ	Max	Units
V <sub>IH</sub>	Input High Voltage		2	-	V <sub>DD</sub> +0.3	V
V <sub>IL</sub>	Input Low Voltage		-0.3	-	0.8	
V <sub>OH</sub>	Output High Voltage	I <sub>OH</sub> = -8mA	V <sub>DD</sub> -0.4	-	-	
V <sub>OL</sub>	Output Low Voltage	I <sub>OL</sub> = 8mA	-	-	0.4	
I <sub>IH</sub>	Input High Current	V <sub>IN</sub> = V <sub>DD</sub> - 0.1V	-	-	45	μA
I <sub>IL</sub>	Input Low Current	V <sub>IN</sub> = 0V	-45	-	-	
R <sub>PU</sub>	Internal Pull-Up Resistance	PDRESET	-	216	-	kOhm
R <sub>DN</sub>	Internal Pull-Down Resistance	25M_OUT1, 25M_OUT2	-	110	-	

### HCSL DC Electrical Characteristics

Over Operating Conditions

Symbol	Parameter	Conditions	Min	Typ	Max	Units
$V_{OH}$	Output High Voltage		660	-	950	mV
$V_{OL}$	Output Low Voltage		-	-	150	
$V_{CROSS}$	Absolute Crossing Point Voltages		250	-	550	
$\Delta V_{CROSS}$	Total variation of $V_{CROSS}$ overall edges		-	-	140	
$I_{OH}$	Input High Current	With 475-Ohm resistor connected between $I_{REF}$ pin and GND	-	12	-	mA

### LVC MOS AC Electrical Characteristics

Over Operating Conditions

Symbol	Parameter	Conditions	Min	Typ	Max	Units
$F_{in}$	Input Frequency		-	25	-	MHz
$F_{OUT}$	Output Frequency	$C_{LOAD} = 15\text{pF}$	-	25	-	
$T_r/T_f$	Output Rise/Fall time	20% of $V_{DD}$ to 80% of $V_{DD}$	-	-	1.2	ns
$T_{DC}$	Output Duty Cycle		45	-	55	%
$T_j$	Period Jitter	25 MHz clock output	-	-	30	ps

### HCSL AC Switching Characteristics<sup>1,2,3</sup>

Over Operating Conditions

Symbol	Parameter	Conditions	Min	Typ	Max	Units
$F_{OUT}$	Output Frequency	HCSL termination	-	-	100	MHz
$T_r/T_f$	Output Rise/Fall time	Between 0.175V and 0.525V	175	-	700	ps
$\Delta T_r/\Delta T_f$	Rise and Fall Time Variation <sup>2</sup>		-	-	125	ps
$T_{DC}$	Output Duty Cycle <sup>3</sup>		47	-	53	%
$T_{ej}$	Cycle-to-Cycle Jitter <sup>3</sup>	Differential waveform	-	-	70	ps
$T_{PJ}$	Peak-to-Peak Phase Jitter	Using PCIe jitter measurement method			86	ps
$J_{RMS2.0}$	PCIe 2.0 RMS Phase Jitter	PCIe 2.0 Test Method @ 100MHz Output			3.1	ps

Notes:

1. Test configuration is  $R_s=33\Omega$ ,  $R_p=49.9\Omega$ , and 2pF
2. Measurement taken from a single-ended waveform.
3. Measurement taken from a differential waveform.

**HCSL Output Buffer Characteristics**

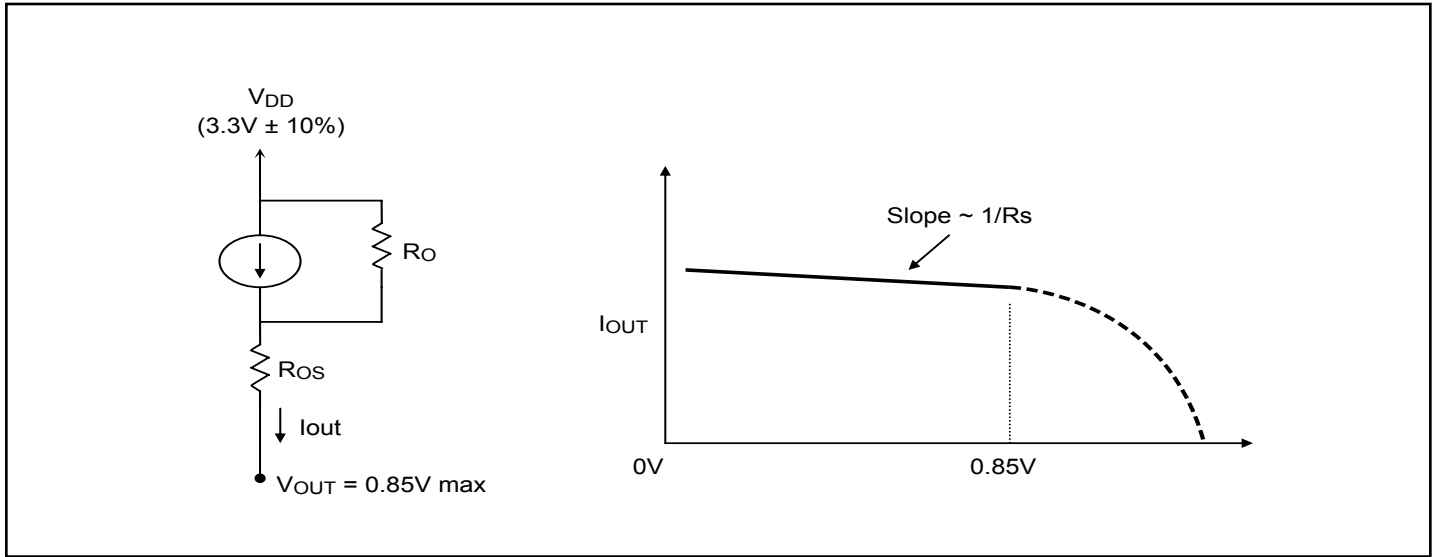

**HCSL Output Buffer Characteristics**

Symbol	Minimum	Maximum
$R_O$	3000Ω	N/A
$R_{OS}$	unspecified	unspecified
$V_{OUT}$	N/A	950mV

**Configuration Test Load Board Termination for HCSL Outputs**

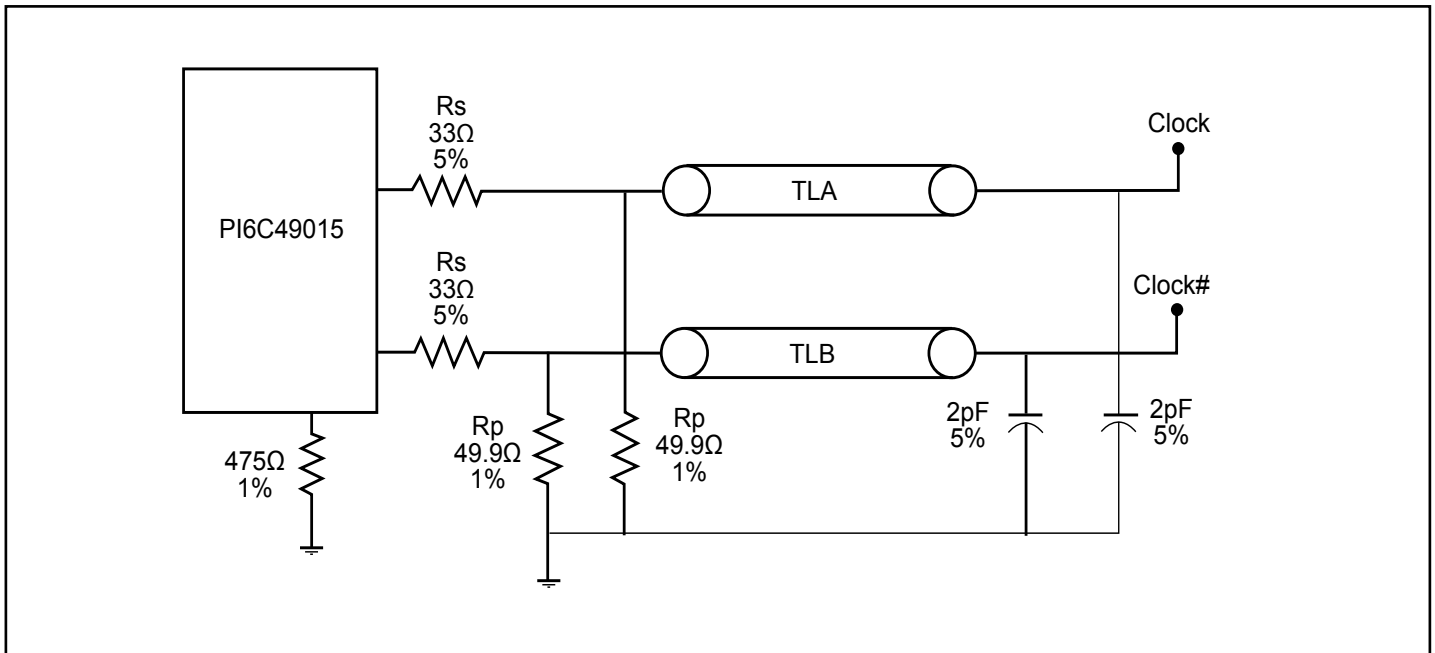



**LVCMOS Test Circuit**

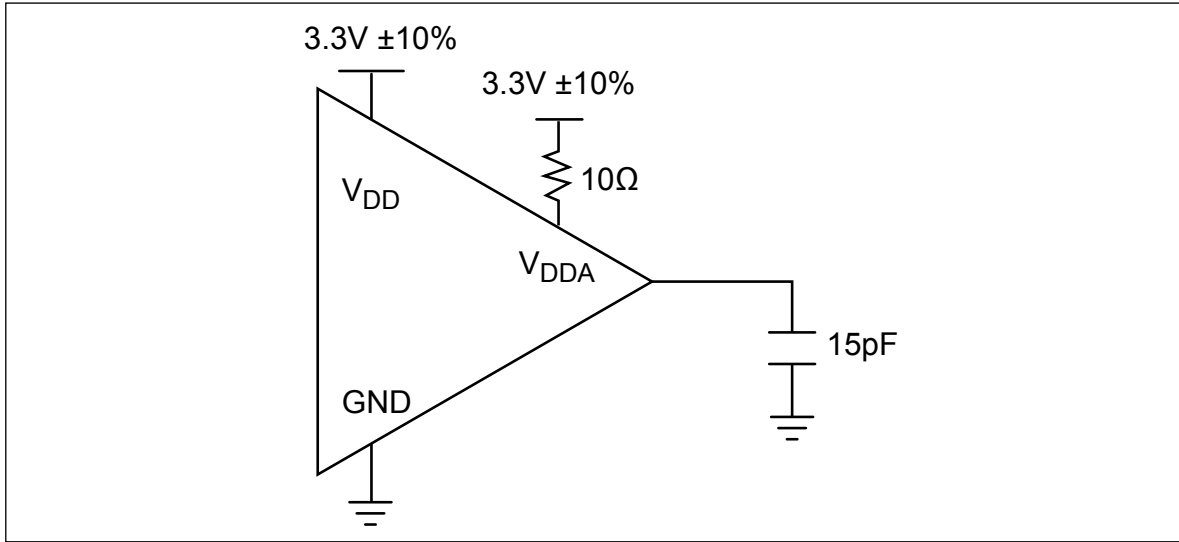

**Application Notes**

**Crystal circuit connection**

The following diagram shows PI6C49015 crystal circuit connection with a parallel crystal. For the CL=18pF crystal, it is suggested to use C1= 18pF, C2= 18pF. C1 and C2 can be adjusted to fine tune to the target ppm of crystal oscillator according to different board layouts.

**Crystal Oscillator Circuit**

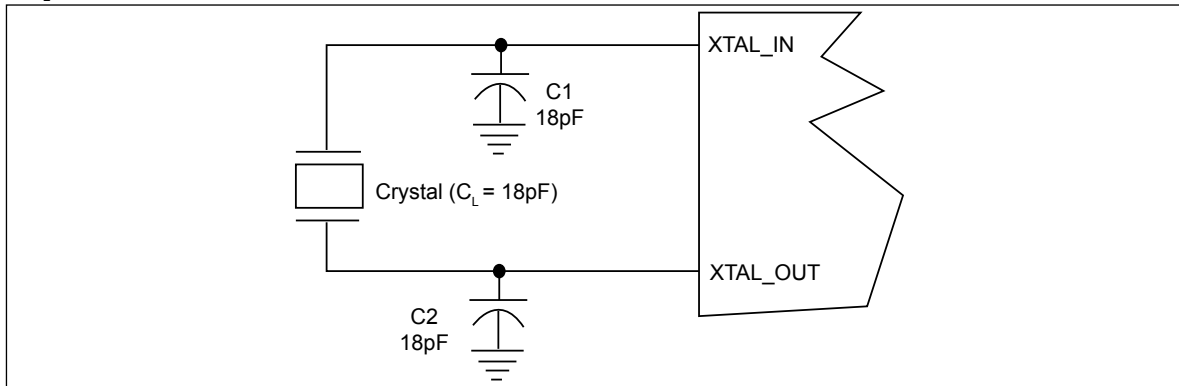

**Recommended Crystal Specification**

Pericom recommends:

- a) GC2500003 XTAL 49S/SMD(4.0 mm), 25M, CL=18pF, +/-30ppm, [http://www.pericom.com/pdf/datasheets/se/GC\\_GF.pdf](http://www.pericom.com/pdf/datasheets/se/GC_GF.pdf)
- b) FY2500081, SMD 5x3.2(4P), 25M, CL=18pF, +/-30ppm, [http://www.pericom.com/pdf/datasheets/se/FY\\_F9.pdf](http://www.pericom.com/pdf/datasheets/se/FY_F9.pdf)
- c) FL2500047, SMD 3.2x2.5(4P), 25M, CL=18pF, +/-20ppm, <http://www.pericom.com/pdf/datasheets/se/FL.pdf>

DOCUMENT CONTROL NO.  
PD - 1313

REVISION: D  
DATE: 03/09/05

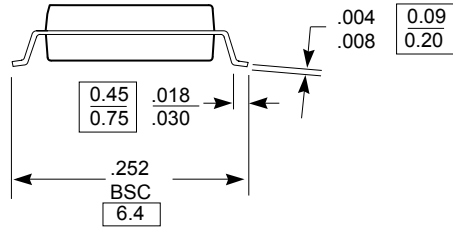
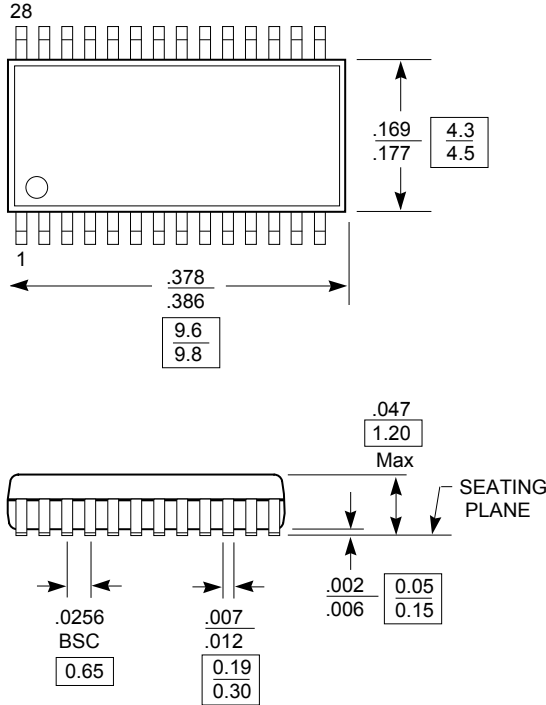

**Note:**

1. Package Outline Exclusive of Mold Flash and Metal Burr
2. Controlling dimensions in millimeters
3. Ref: JEDEC MO-153F/AE



Pericom Semiconductor Corporation  
3545 N. 1st Street, San Jose, CA 95134  
1-800-435-2335 • www.pericom.com

DESCRIPTION: 28-Pin, 173-Mil Wide, TSSOP

PACKAGE CODE: L

**Note:**

- For latest package info, please check: <http://www.pericom.com/products/packaging/mechanicals.php>

**Ordering Information**<sup>(1-3)</sup>

Ordering Code	Package Code	Package Description
PI6C49015LIE	L	28 pin, Pb-free & Green, TSSOP (L28)

**Notes:**

1. Thermal characteristics can be found on the company web site at [www.pericom.com/packaging/](http://www.pericom.com/packaging/)
2. E = Pb-free and Green
3. Adding an X suffix = Tape/Reel