



## Tango 3

2G/GPRS & 3G Through Hole Antenna

### Key Features

- Compact size
- Tri-band 2G + 3G
- Wide frequency range



### General Description

The Tango 3 is tuned to tri band 2G/GPRS & 3G/UMTS frequencies. It is suited to industrial and automotive applications for panel mounting to (up to 4mm thick) and is manufactured with an O ring seal to prevent moisture ingress once installed.

The brass foot has a ridged topside allowing secure fitting to the enclosure and a 6mm diameter screw thread for mounting the antenna.

Supplied as standard with a 3m cable and either SMA Male or FME Female connectors. Alternative cable lengths or connector types may be specified for volume orders.

### Additional Considerations

- Panel mounted
- Meets all EU compliance criteria for electronic goods





## Tango 3

2G/GPRS & 3G Through Hole Antenna

### Electrical Specifications

Temperature range:	-40 to 85°C
Operating Frequencies:	869-960/1710-1990MHz
Impedance:	50 Ohm
Gain:	2.5dBi
VSWR:	<2.0
Operating frequencies:	GSM / GPRS - 900, 1800, 1900MHz 3G - 2.1GHz
Polarization:	Vertical
Radiation:	Omni directional
Max Power:	20W

### Mechanical Specifications

Dimensions:	L76 x W29 x 10mm Ø
Cable:	RG58
Connector:	SMA Male
Mounting method:	Through hole

### Return Loss and VSWR

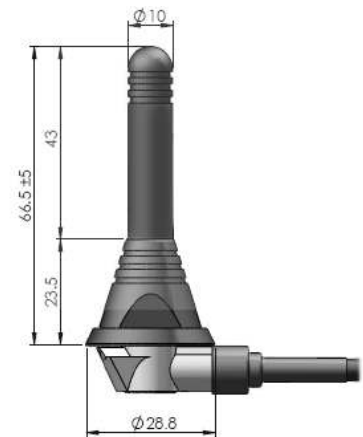
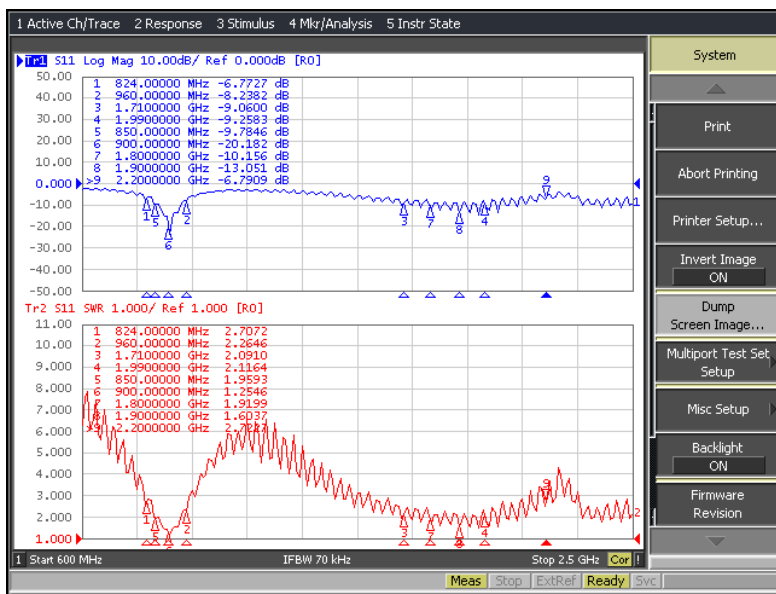

### Ordering Details

Part Number	Description
TANGO3/3M/SMAM/S/S/31	2G/GPRS & 3G Through Hole Antenna
TANGO3/3M/FMEF/S/S/31	2G/GPRS & 3G Through Hole Antenna