



March 2015

## 74VHC14 Hex Schmitt Inverter

### Features

- High Speed:  $t_{PD} = 5.5$  ns (Typ.) at  $V_{CC} = 5$  V
- Low Power Dissipation:  $I_{CC} = 2$  A (Max.) at  $T_A = 25^\circ\text{C}$
- High Noise Immunity:  $V_{NIH} = V_{NIL} = 28\%$   $V_{CC}$  (Min.)
- Power down protection is provided on all inputs
- Low Noise:  $V_{OLP} = 0.8$  V (Max.)
- Pin and Function Compatible with 74HC14

### General Description

The VHC14 is an advanced high speed CMOS Hex Schmitt Inverter fabricated with silicon gate CMOS technology. It achieves the high speed operation similar to equivalent Bipolar Schottky TTL while maintaining the CMOS low power dissipation. Pin configuration and function are the same as the VHC04 but the inputs have hysteresis between the positive-going and negative-going input thresholds, which are capable of transforming slowly changing input signals into sharply defined, jitter-free output signals, thus providing greater noise margin than conventional inverters.

An input protection circuit ensures that 0 V to 7 V can be applied to the input pins without regard to the supply voltage. This device can be used to interface 5 V to 3 V systems and two supply systems such as battery back up. This circuit prevents device destruction due to mismatched supply and input voltages.

### Ordering Information

Part Number	Top Mark	Package	Packing Method
74VHC14M	74VHC14	SOIC 14L	Rail
74VHC14MX	74VHC14	SOIC 14L	Tape and Reel
74VHC14SJX	VHC14	SOP 14L	Tape and Reel
74VHC14MTC	V14	TSSOP 14L	Rail
74VHC14MTCX	V14	TSSOP 14L	Tape and Reel

### Logic Symbol/s

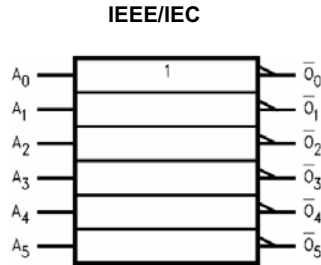

### Connection Diagram/s

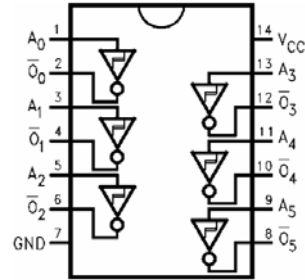

### Pin Descriptions

Pin Names	Description
$A_n$	Inputs
$\overline{O}_n$	Outputs

### Truth Table/s

A	O
L	H
H	L

### Absolute Maximum Ratings<sup>(1)</sup>

Stresses exceeding the absolute maximum ratings may damage the device. The device may not function or be operable above the recommended operating conditions and stressing the parts to these levels is not recommended. In addition, extended exposure to stresses above the recommended operating conditions may affect device reliability. The absolute maximum ratings are stress ratings only.

Symbol	Parameter	Value	Unit
$V_{CC}$	Supply Voltage	-0.5 to +7.0	V
$V_{IN}$	DC Input Voltage	-0.5 to +7.0	V
$V_{OUT}$	DC Output Voltage	-0.5 to $V_{CC}+0.5$	V
$I_{IK}$	Input Diode Current	-20	mA
$I_{OK}$	Output Diode Current	$\pm 20$	mA
$I_{OUT}$	DC Output Current	$\pm 25$	mA
$I_{CC}$	DC $V_{CC}$ / GND Current	$\pm 50$	mA
$T_{STG}$	Storage Temperature Range	-65 to +150	$^{\circ}C$
$T_L$	Lead Temperature (Soldering 10 seconds)	260	$^{\circ}C$

#### Note:

1. Absolute maximum ratings are values beyond which the device may be damaged or have its useful life impaired. The data book specifications should be met, without exception, to ensure that the system design is reliable over its power supply, temperature, and output/input loading variables. Fairchild does not recommend operation outside data-book specifications.

## Recommended Operating Conditions<sup>(2)</sup>

The Recommended Operating Conditions table defines the conditions for actual device operation. Recommended operating conditions are specified to ensure optimal performance to the datasheet specifications. Fairchild does not recommend exceeding them or designing to absolute maximum ratings.

Symbol	Parameter	Min.	Max.	Unit
$V_{CC}$	Supply Voltage	2.0	5.5	V
$V_{IN}$	Input Voltage	0	5.5	V
$V_{OUT}$	Output Voltage	0	$V_{CC}$	V
$T_{OPR}$	Operating Temperature Range	-40	85	°C

### Note:

2. Unused inputs must be held HIGH or LOW. They may not float.

## DC Electrical Characteristics

Symbol	Parameter	$V_{CC}$	$T_A = 25^\circ\text{C}$			$T_A = -40 \text{ to } 85^\circ\text{C}$		Unit	Conditions	
			Min.	Typ.	Max.	Min.	Max.			
$V_P$	Positive Threshold Voltage	3.0			2.20		2.20	V		
		4.5			3.15		3.15			
		5.5			3.85		3.85			
$V_N$	Negative Threshold Voltage	3.0	0.90			0.90		V		
		4.5	1.35			1.35				
		5.5	1.65			1.65				
$V_H$	Hysteresis Voltage	3.0	0.30		1.20	0.30	1.20	V		
		4.5	0.40		1.40	0.40	1.40			
		5.5	0.50		1.60	0.50	1.60			
$V_{OH}$	HIGH Level Output Voltage	2.0	1.9	2.0		1.9		V	$V_{IN} = V_{IL}$	$I_{OH} = -50 \text{ A}$
		3.0	2.9	3.0		2.9				$I_{OH} = -4 \text{ mA}$
		4.5	4.4	4.5		4.4				$I_{OH} = -8 \text{ mA}$
		3.0	2.58			2.48				
		4.5	3.94			3.80				
$V_{OL}$	LOW Level Output Voltage	2.0		0.0	0.1		0.1	V	$V_{IN} = V_{IH}$	$I_{OL} = 50 \text{ A}$
		3.0		0.0	0.1		0.1			
		4.5		0.0	0.1		0.1			
		3.0			0.36		0.44			$I_{OL} = 4 \text{ mA}$
		4.5			0.36		0.44			$I_{OL} = 8 \text{ mA}$
$I_{IN}$	Input Leakage Current	0 - 5.5			$\pm 0.1$		$\pm 1.0$	A	$V_{IN} = 5.5 \text{ V or GND}$	
$I_{CC}$	Quiescent Supply Current	5.5			2.0		20.0	A	$V_{IN} = V_{CC} \text{ or GND}$	

**Noise Characteristics<sup>(2)</sup>**

Symbol	Parameter	V <sub>CC</sub>	T <sub>A</sub> = 25°C		Unit	Conditions
			Typ.	Max.		
V <sub>OLP</sub>	Quiet Output Maximum Dynamic V <sub>OL</sub>	5.0	0.4	0.8	V	C <sub>L</sub> = 50 pF
V <sub>OLV</sub>	Quiet Output Minimum Dynamic V <sub>OL</sub>	5.0	-0.4	0.8	V	C <sub>L</sub> = 50 pF
V <sub>IHD</sub>	Minimum HIGH Level Dynamic Input Voltage	5.0		3.5	V	C <sub>L</sub> = 50 pF
V <sub>ILD</sub>	Maximum LOW Level Dynamic Input Voltage	5.0		1.5	V	C <sub>L</sub> = 50 pF

**Note:**

2. Parameter guaranteed by design.

**AC Electrical Characteristics**

Symbol	Parameter	V <sub>CC</sub>	T <sub>A</sub> = 25°C			T <sub>A</sub> = -40 to 85°C		Unit	Conditions
			Min.	Typ.	Max.	Min.	Max.		
t <sub>PLH</sub> t <sub>PHL</sub>	Propagation Delay Time	3.3 ± 0.3		8.3	12.8	1.0	15.0	ns	C <sub>L</sub> = 15 pF
				10.8	16.3	1.0	18.5		C <sub>L</sub> = 50 pF
		5.0 ± 0.5		5.5	8.6	1.0	10.0		C <sub>L</sub> = 15 pF
				7.0	10.6	1.0	12.0		C <sub>L</sub> = 50 pF
C <sub>IN</sub>	Input Capacitance			4	10		10	pF	V <sub>CC</sub> = Open
C <sub>PD</sub>	Power Dissipation Capacitance			21				pF	<sup>(3)</sup>

**Note:**

3. C<sub>PD</sub> is defined as the value of the internal equivalent capacitance which is calculated from the opening current consumption without load.

Average operating current can be obtained by the equation: I<sub>CC</sub> (Opr) = C<sub>PD</sub> \* V<sub>CC</sub> \* f<sub>IN</sub> + I<sub>CC</sub> /6 (per Gate)

Physical Dimensions

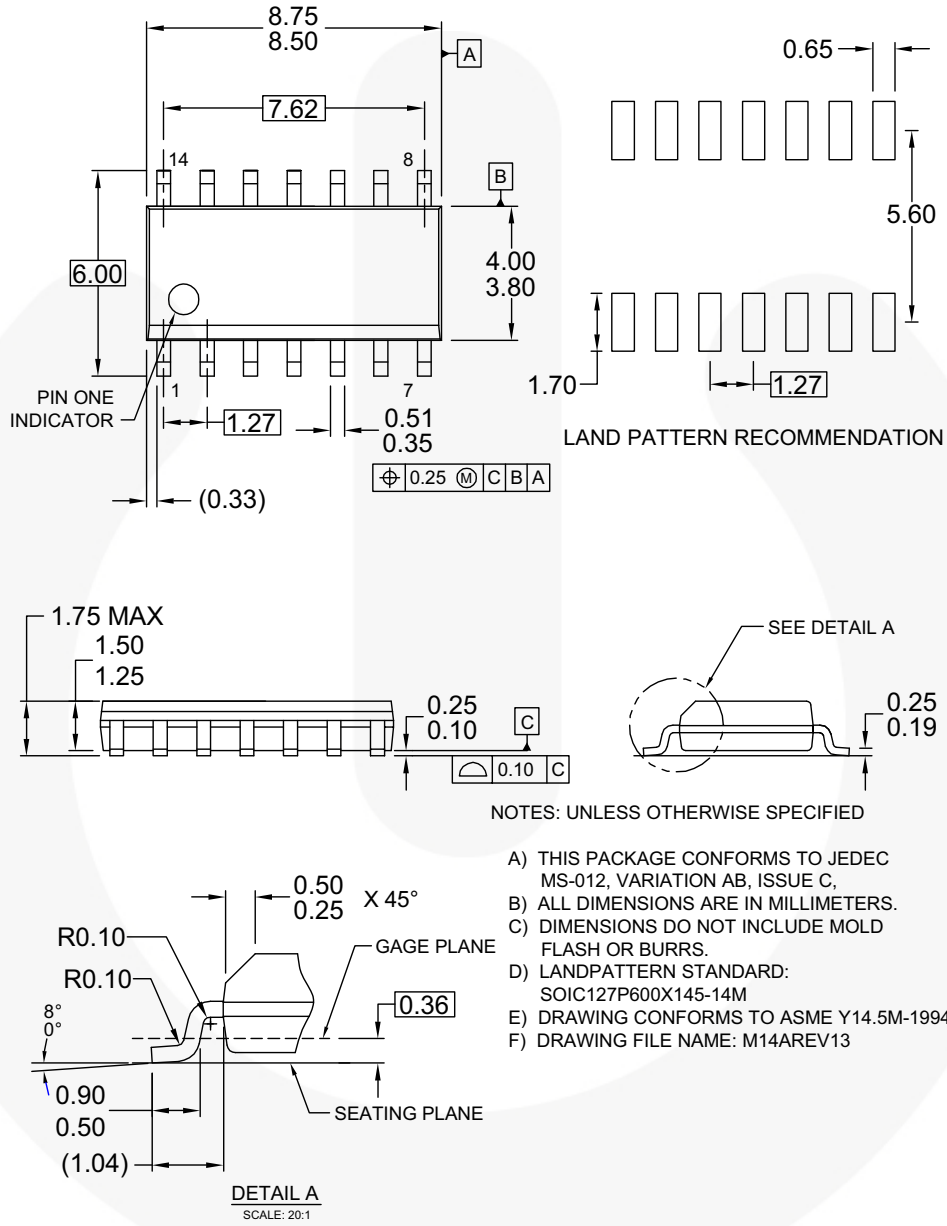
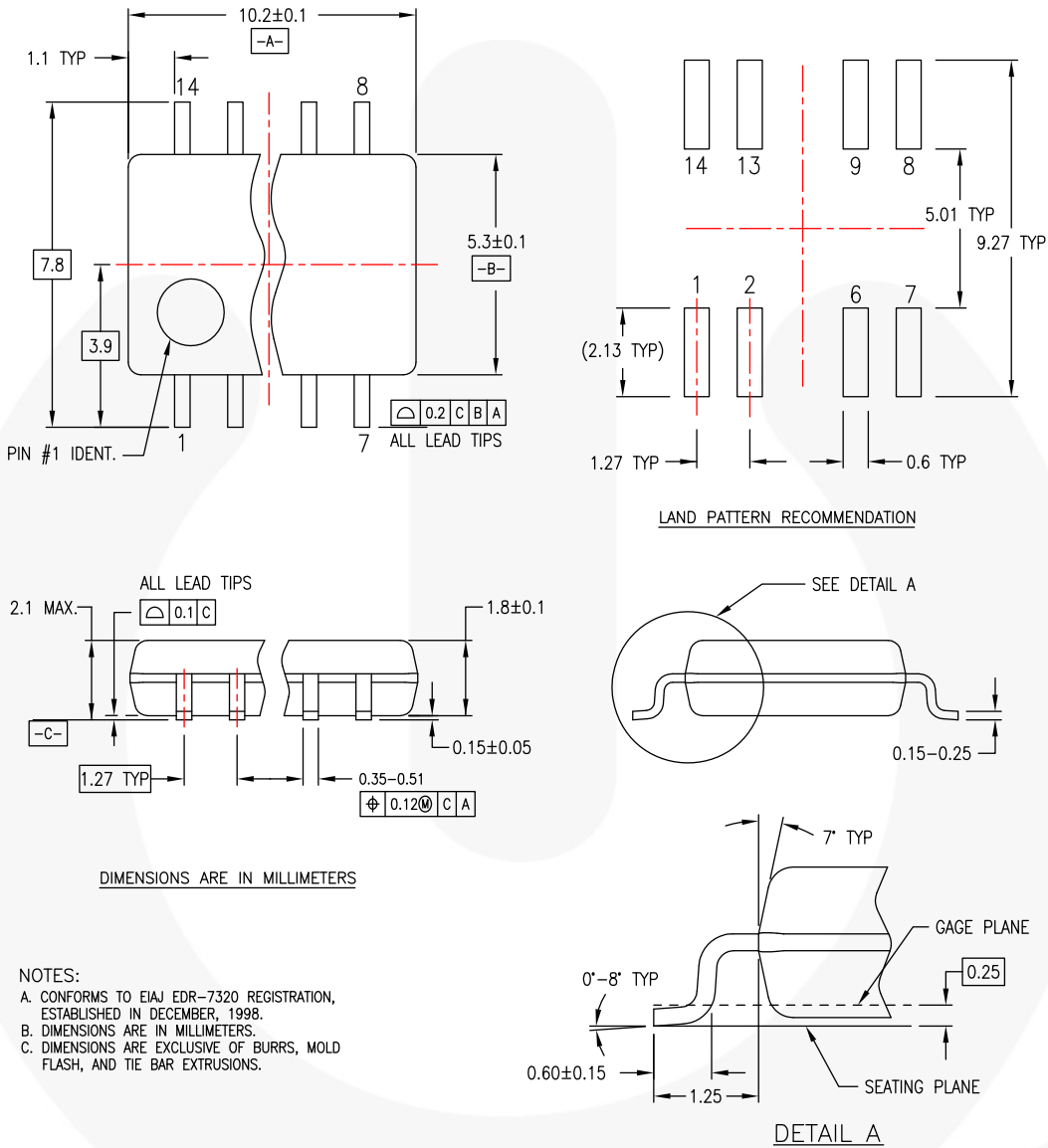

Figure 1. 14-LEAD, SOIC, JEDEC MS-012, 0.150 INCH, NARROW BODY

Physical Dimensions (Continued)



M14DREVC

Figure 2. 14-LEAD, SOP, EIAJ TYPE II, 5.0 MM WIDE

Physical Dimensions (Continued)

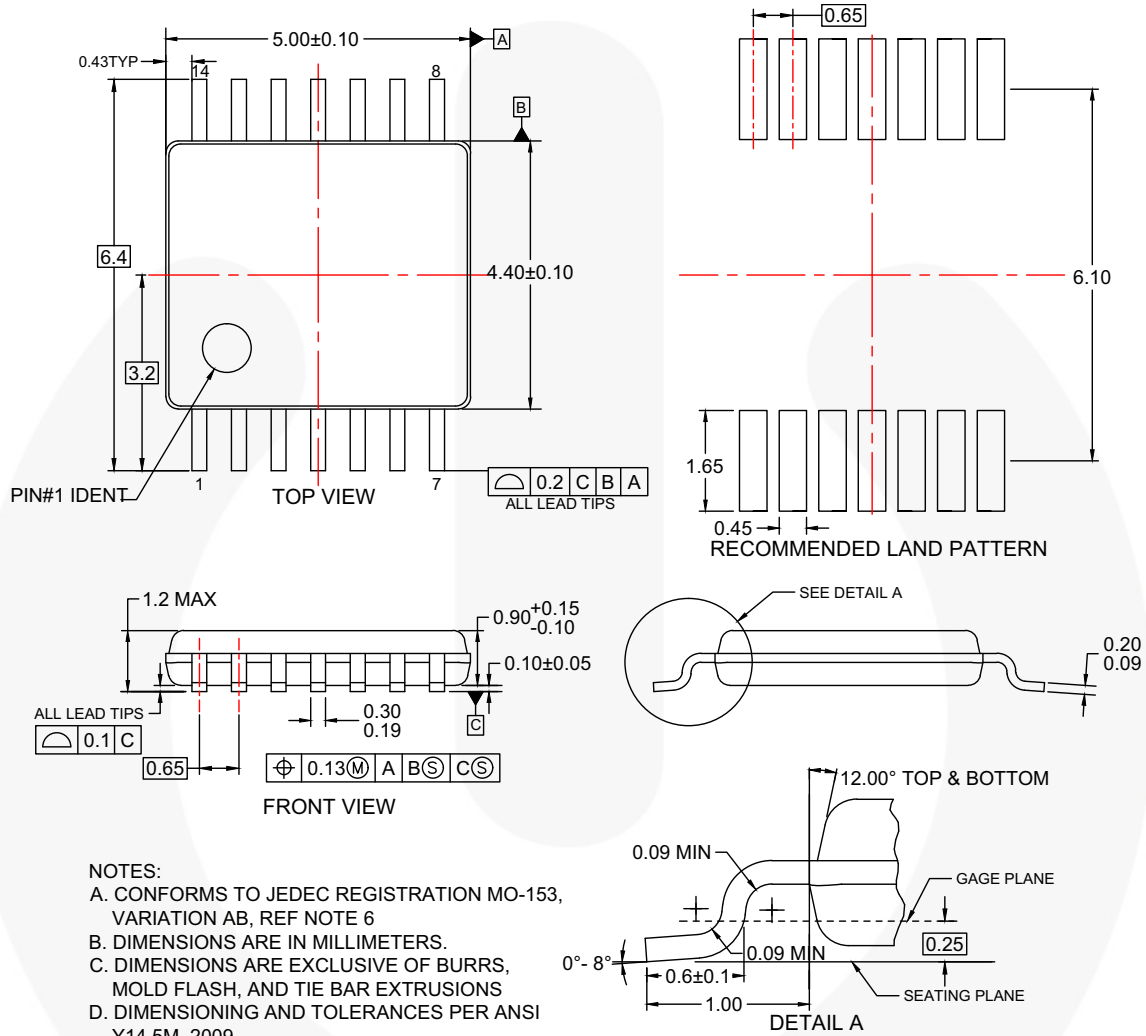

- NOTES:
- A. CONFORMS TO JEDEC REGISTRATION MO-153, VARIATION AB, REF NOTE 6
  - B. DIMENSIONS ARE IN MILLIMETERS.
  - C. DIMENSIONS ARE EXCLUSIVE OF BURRS, MOLD FLASH, AND TIE BAR EXTRUSIONS
  - D. DIMENSIONING AND TOLERANCES PER ANSI Y14.5M, 2009.
  - E. LANDPATTERN STANDARD: SOP65P640X110-14M.
  - F. DRAWING FILE NAME: MKT-MTC14rev7.







Figure 3. 14-LEAD, TSSOP, JEDEC MO-153, 4.4 MM WIDE



**TRADEMARKS**

The following includes registered and unregistered trademarks and service marks, owned by Fairchild Semiconductor and/or its global subsidiaries, and is not intended to be an exhaustive list of all such trademarks.

- |                                                                                              |                                                |                                                                                     |                                                                                                     |
|----------------------------------------------------------------------------------------------|------------------------------------------------|-------------------------------------------------------------------------------------|-----------------------------------------------------------------------------------------------------|
| AccuPower™                                                                                   | F-PFS™                                         | OPTOPLANAR®                                                                         |  SYSTEM GENERAL® |
| AttitudeEngine™                                                                              | FRFET®                                         |  ® | TinyBoost®                                                                                          |
| Awinda®                                                                                      | Global Power Resource™                         | PowerTrench®                                                                        | TinyBuck®                                                                                           |
| AX-CAP®*                                                                                     | GreenBridge™                                   | PowerXS™                                                                            | TinyCalc™                                                                                           |
| BitSiC™                                                                                      | Green FPS™                                     | Programmable Active Droop™                                                          | TinyLogic®                                                                                          |
| Build it Now™                                                                                | Green FPS™ e-Series™                           | QFET®                                                                               | TINYOPTO™                                                                                           |
| CorePLUS™                                                                                    | Gmax™                                          | QS™                                                                                 | TinyPower™                                                                                          |
| CorePOWER™                                                                                   | GTO™                                           | Quiet Series™                                                                       | TinyPWM™                                                                                            |
| CROSSVOLT™                                                                                   | IntelliMAX™                                    | RapidConfigure™                                                                     | TinyWire™                                                                                           |
| CTL™                                                                                         | ISOPLANAR™                                     |  ™ | TranSiC™                                                                                            |
| Current Transfer Logic™                                                                      | Making Small Speakers Sound Louder and Better™ | Saving our world, 1mW/W/kW at a time™                                               | TriFault Detect™                                                                                    |
| DEUXPEED®                                                                                    | MegaBuck™                                      | SignalWise™                                                                         | TRUECURRENT®*                                                                                       |
| Dual Cool™                                                                                   | MICROCOUPLER™                                  | SmartMax™                                                                           | SerDes™                                                                                             |
| EcoSPARK®                                                                                    | MicroFET™                                      | SMART START™                                                                        |  SerDes™         |
| EfficientMax™                                                                                | MicroPak™                                      | Solutions for Your Success™                                                         | UHC®                                                                                                |
| ESBC™                                                                                        | MicroPak2™                                     | SPM®                                                                                | Ultra FRFET™                                                                                        |
|  Fairchild® | MillerDrive™                                   | STEALTH™                                                                            | UniFET™                                                                                             |
| Fairchild Semiconductor®                                                                     | MotionMax™                                     | SuperFET®                                                                           | VCX™                                                                                                |
| FACT Quiet Series™                                                                           | MotionGrid®                                    | SuperSOT™-3                                                                         | VisualMax™                                                                                          |
| FACT®                                                                                        | MTi®                                           | SuperSOT™-6                                                                         | VoltagePlus™                                                                                        |
| FAST®                                                                                        | MTx®                                           | SuperSOT™-8                                                                         | XS™                                                                                                 |
| FastvCore™                                                                                   | MVN®                                           | SupreMOS®                                                                           | Xsens™                                                                                              |
| FETBench™                                                                                    | mWSaver®                                       | SyncFET™                                                                            | 仙童™                                                                                                 |
| FPS™                                                                                         | OptoHiT™                                       | Sync-Lock™                                                                          |                                                                                                     |
|                                                                                              | OPTOLOGIC®                                     |                                                                                     |                                                                                                     |

\* Trademarks of System General Corporation, used under license by Fairchild Semiconductor.

**DISCLAIMER**

FAIRCHILD SEMICONDUCTOR RESERVES THE RIGHT TO MAKE CHANGES WITHOUT FURTHER NOTICE TO ANY PRODUCTS HEREIN TO IMPROVE RELIABILITY, FUNCTION, OR DESIGN. TO OBTAIN THE LATEST, MOST UP-TO-DATE DATASHEET AND PRODUCT INFORMATION, VISIT OUR WEBSITE AT [HTTP://WWW.FAIRCHILDSEMI.COM](http://www.fairchildsemi.com). FAIRCHILD DOES NOT ASSUME ANY LIABILITY ARISING OUT OF THE APPLICATION OR USE OF ANY PRODUCT OR CIRCUIT DESCRIBED HEREIN; NEITHER DOES IT CONVEY ANY LICENSE UNDER ITS PATENT RIGHTS, NOR THE RIGHTS OF OTHERS. THESE SPECIFICATIONS DO NOT EXPAND THE TERMS OF FAIRCHILD'S WORLDWIDE TERMS AND CONDITIONS, SPECIFICALLY THE WARRANTY THEREIN, WHICH COVERS THESE PRODUCTS.

**LIFE SUPPORT POLICY**

FAIRCHILD'S PRODUCTS ARE NOT AUTHORIZED FOR USE AS CRITICAL COMPONENTS IN LIFE SUPPORT DEVICES OR SYSTEMS WITHOUT THE EXPRESS WRITTEN APPROVAL OF FAIRCHILD SEMICONDUCTOR CORPORATION.

As used herein:

1. Life support devices or systems are devices or systems which, (a) are intended for surgical implant into the body or (b) support or sustain life, and (c) whose failure to perform when properly used in accordance with instructions for use provided in the labeling, can be reasonably expected to result in a significant injury of the user.
2. A critical component in any component of a life support, device, or system whose failure to perform can be reasonably expected to cause the failure of the life support device or system, or to affect its safety or effectiveness.

**ANTI-COUNTERFEITING POLICY**

Fairchild Semiconductor Corporation's Anti-Counterfeiting Policy. Fairchild's Anti-Counterfeiting Policy is also stated on our external website, [www.fairchildsemi.com](http://www.fairchildsemi.com), under Sales Support.

Counterfeiting of semiconductor parts is a growing problem in the industry. All manufacturers of semiconductor products are experiencing counterfeiting of their parts. Customers who inadvertently purchase counterfeit parts experience many problems such as loss of brand reputation, substandard performance, failed applications, and increased cost of production and manufacturing delays. Fairchild is taking strong measures to protect ourselves and our customers from the proliferation of counterfeit parts. Fairchild strongly encourages customers to purchase Fairchild parts either directly from Fairchild or from Authorized Fairchild Distributors who are listed by country on our web page cited above. Products customers buy either from Fairchild directly or from Authorized Fairchild Distributors are genuine parts, have full traceability, meet Fairchild's quality standards for handling and storage and provide access to Fairchild's full range of up-to-date technical and product information. Fairchild and our Authorized Distributors will stand behind all warranties and will appropriately address any warranty issues that may arise. Fairchild will not provide any warranty coverage or other assistance for parts bought from Unauthorized Sources. Fairchild is committed to combat this global problem and encourage our customers to do their part in stopping this practice by buying direct or from authorized distributors.

**PRODUCT STATUS DEFINITIONS**

**Definition of Terms**

Datasheet Identification	Product Status	Definition
Advance Information	Formative / In Design	Datasheet contains the design specifications for product development. Specifications may change in any manner without notice.
Preliminary	First Production	Datasheet contains preliminary data; supplementary data will be published at a later date. Fairchild Semiconductor reserves the right to make changes at any time without notice to improve design.
No Identification Needed	Full Production	Datasheet contains final specifications. Fairchild Semiconductor reserves the right to make changes at any time without notice to improve the design.
Obsolete	Not In Production	Datasheet contains specifications on a product that is discontinued by Fairchild Semiconductor. The datasheet is for reference information only.

Rev. I73