

This drawing involves proprietary design rights of Tyco Electronics Corporation, and all design, manufacture, reproduction, use and sale rights regarding the same are expressly reserved. It is submitted for a specific purpose and the recipient by accepting this drawing, assumes custody and control and agrees to take reasonable precautions; (a) that this drawing will not be copied and reproduced, in whole or in part, or its contents revealed in any manner, or to any person except to meet the purpose for which it was delivered and (b) that any special features peculiar to this design will not be incorporated in other projects without the expressed written permission of Tyco Electronics Corporation.

REVISIONS			
EC	REV	DESCRIPTION	DATE
ECD-17-008524	A1	CLARIFY THE P/N AND LOGO	06/13/17

9. ELCON LOGO IS OPTIONAL

8. ITEMS PROVIDED TO THIS SPECIFICATION TO BE PERMANENTLY IDENTIFIED PER THE FOLLOWING IDENTIFIER:

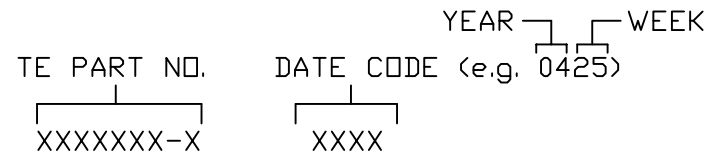

7. RECOMMENDED PRESSING FIXTURE: FIX00001 FOR COMPLIANT APPLICATION IS AVAILABLE. PLEASE CONSULT FACTORY.

6. EXAMPLE PCB CONFIGURATION.

5. THIS CONFIGURATION WITH 3-SEGMENT SIGNAL CONNECTOR IS SHOWN FOR REFERENCE ONLY. COMBINATION OF MULTIPLE NUMBERS OF 2 AND 3 SEGMENT MODULES COULD BE USED PER USER PREFERENCE. OVERALL COMBINATION SHOULD NOT EXCEED 8.0" IN LENGTH.

4. SOCKETS ACCEPT 1.6 [.062] ± 10% THICK PC BOARD.

3. FINISHES:

CONTACTS: SELECTIVE GOLD PER MIL-G-45204, .000030" MIN. THK, OVER NICKEL PER QQ-N-290

TERMINALS: SELECTIVE TIN PER ASTM B-545, OVER NICKEL PER QQ-N-290

2. MATERIALS:

INSULATORS: THERMOPLASTIC, GLASS REINFORCED, COLOR-BLACK UL94V-0 FLAMMABILITY RATED.

POWER CONTACTS: COPPER ALLOY

1. PART NUMBER CHANGES AND OR DESIGN CHANGES AFFECTING ITEM INTERCHANGEABILITY REQUIRE PRIOR TE APPROVAL AND AUTHORIZATION BY REVISION TO THIS DRAWING.

NOTES: UNLESS OTHERWISE SPECIFIED;

9. PART NUMBER INFORMATION

CONNECTOR	REFERENCE TE PN	ELCON PART NUMBER	TERMINATION TYPE	PC TAIL LENGTH DIM "A"	RECOMMENDED MOUNTING BOARD	MATING BOARD
SOCKET	6651290-2	284-0112-12100	SOLDER TAIL (SHORT)	3.56 [.140] 2.54 [.100]	1.6 [.062] THICK	1.6 [.062] THICK
SOCKET	6651290-3	284-0112-12300	SOLDER TAIL (STANDARD)	5.08 [.200] 4.06 [.160]	3.2 [.125] OR THINNER	1.6 [.062] THICK
SOCKET	6651290-1	284-0112-11300	COMPLIANT TAIL	5.08 [.200] 4.06 [.160]	2.3 [.093] OR THICKER	1.6 [.062] THICK

<p>THIRD ANGLE PROJECTION</p> <p>UNLESS OTHERWISE SPECIFIED DIMENSIONS ARE IN METRIC [INCHES]</p> <p>TOLERANCES</p> <p>ANGLES ± .5°</p> <p>DECIMALS</p> <p>.XX ± .25 [.010]</p> <p>.X ± .5 [.020]</p>	<p>MM OR MM [INCH]</p>	<p>DRAWN</p> <p>HA NGUYEN</p>	<p>DATE</p> <p>06/24/04</p>	<p>tyco Tyco Electronics Corporation Electronics Menlo Park, Ca 94025</p>		<p>ELCON</p>	
	<p>CHECKED</p>	<p>APPROVED</p>	<p>TITLE</p> <p>SOCKET CONNECTOR, CROWNEDGE</p> <p>PN: 284-0112-12100/284-0112-12300</p> <p>PN: 284-0112-11300</p>		<p>SIZE</p> <p>B</p>	<p>DWG NUMBER</p> <p>C = 6651290</p>	<p>REV.</p> <p>A1</p>
	<p>APPROVED</p> <p>D. CHAU</p> <p>06/25/04</p>	<p>APPROVED</p> <p>M. ALIM</p> <p>07/21/04</p>	<p>ACAD FILE NUMBER</p> <p>C6651290A.DWG</p>		<p>DWG SCALE</p> <p>2=1</p>	<p>SH 1 OF 5</p>	
	<p>DRAWN</p> <p>HA NGUYEN</p>		<p>DATE</p> <p>06/24/04</p>		<p>SIZE</p> <p>B</p>		<p>REV.</p> <p>A1</p>

This drawing involves proprietary design rights of Tyco Electronics Corporation, and all design, manufacture, reproduction, use and sale rights regarding the same are expressly reserved. It is submitted for a specific purpose and the recipient by accepting this drawing, assumes custody and control and agrees to take reasonable precautions; (a) that this drawing will not be copied and reproduced, in whole or in part, or its contents revealed in any manner, or to any person except to meet the purpose for which it was delivered and (b) that any special features peculiar to this design will not be incorporated in other projects without the expressed written permission of Tyco Electronics Corporation.

REVISIONS			
EC	REV	DESCRIPTION	DATE
		SEE SHEET 1	

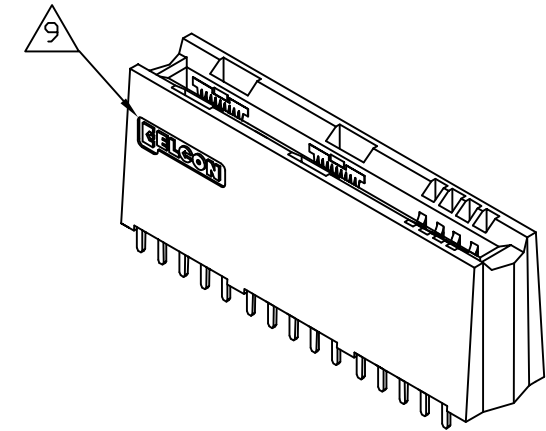
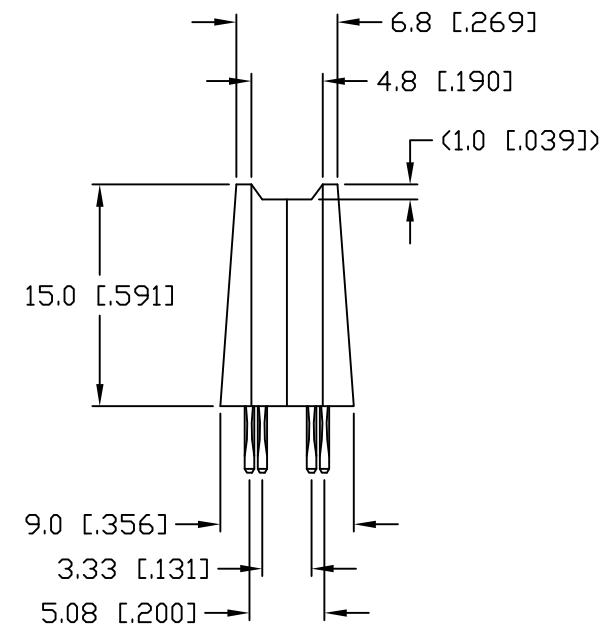
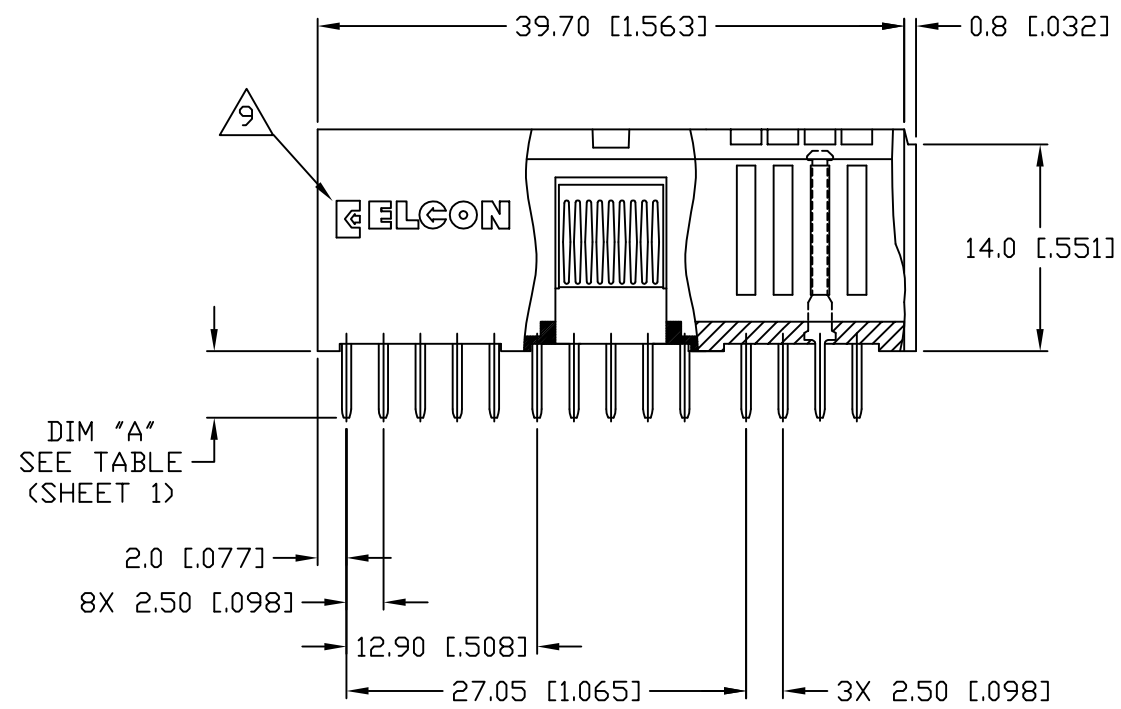
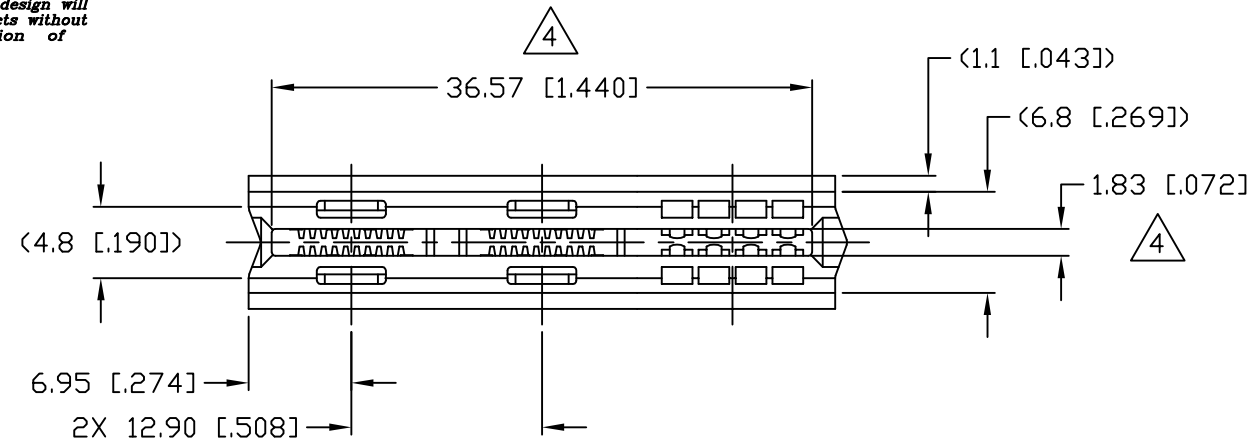

MM OR MM [INCH] THIRD ANGLE PROJECTION UNLESS OTHERWISE SPECIFIED DIMENSIONS ARE IN METRIC [INCHES] TOLERANCES ANGLES ± .5° DECIMALS .XX ± .25 [.010] .X ± .5 [.020]	DRAWN	DATE	Tyco Electronics Corporation Menlo Park, Ca 94025	
	HA NGUYEN	06/24/04	TITLE	
	CHECKED		SOCKET CONNECTOR, 3 SEG, CROWNEDGE STRAIGHT, 4 POWER, 8 SIGNAL, SOLDER PN: 284-0112-12100/284-0112-12300	
	APPROVED		SIZE	REV.
	D. CHAU	06/25/04	B	A1
	DCA APPROVED		C = 6651290	
	M. ALIM	07/21/04		
	ACAD FILE NUMBER	C6651290A.DWG		DWG SCALE 2=1 SH 2 OF 5

This drawing involves proprietary design rights of Tyco Electronics Corporation, and all design, manufacture, reproduction, use and sale rights regarding the same are expressly reserved. It is submitted for a specific purpose and the recipient by accepting this drawing, assumes custody and control and agrees to take reasonable precautions; (a) that this drawing will not be copied and reproduced, in whole or in part, or its contents revealed in any manner, or to any person except to meet the purpose for which it was delivered and (b) that any special features peculiar to this design will not be incorporated in other projects without the expressed written permission of Tyco Electronics Corporation.

REVISIONS			
EC	REV	DESCRIPTION	DATE
		SEE SHEET 1	

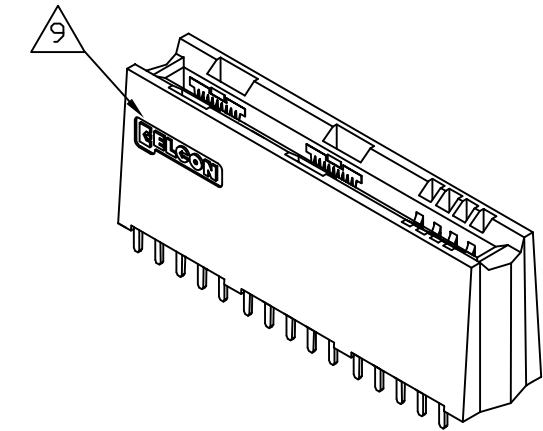
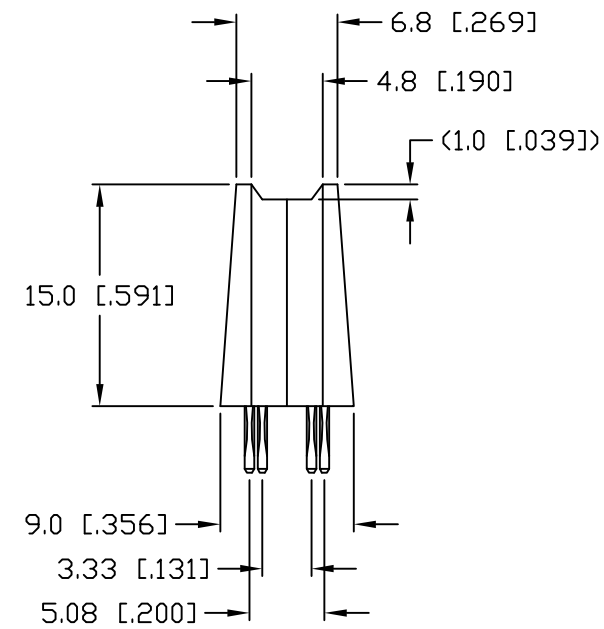
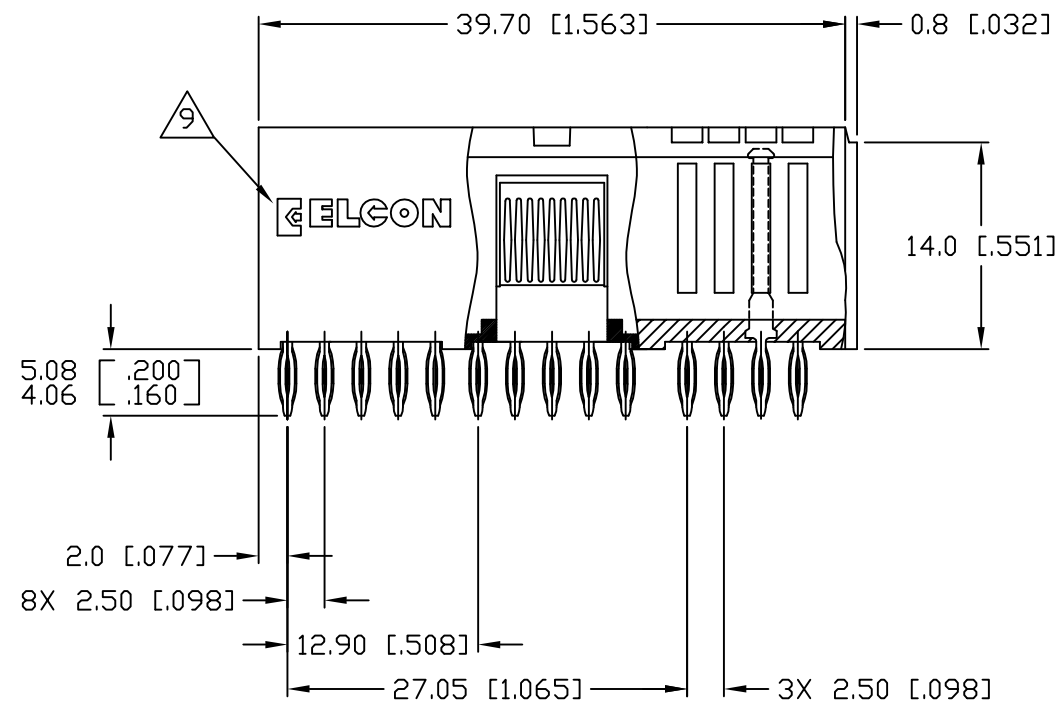
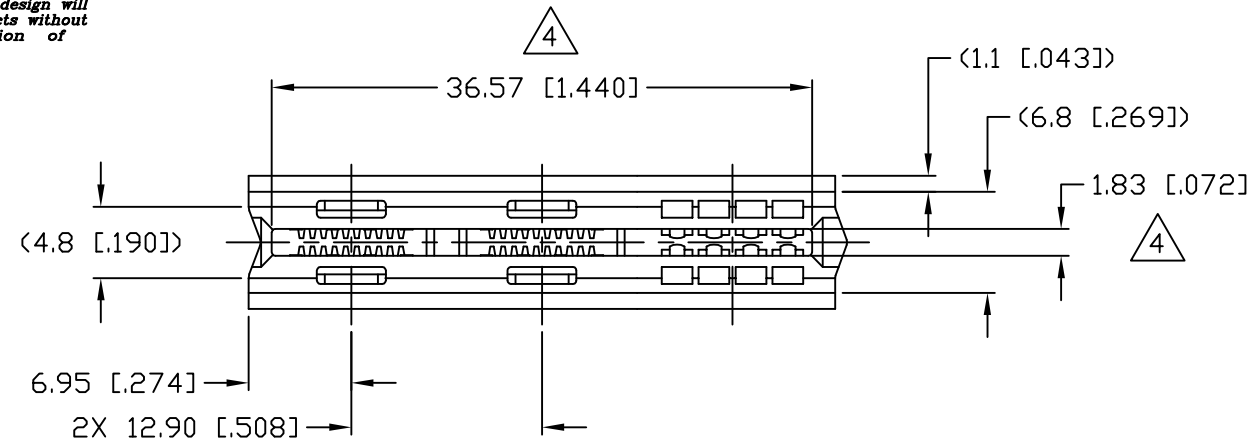

← MM → OR MM [INCH] THIRD ANGLE PROJECTION UNLESS OTHERWISE SPECIFIED DIMENSIONS ARE IN METRIC [INCHES] TOLERANCES ANGLES ± .5° DECIMALS .XX ± .25 [.010] .X ± .5 [.020]	DRAWN HA NGUYEN	DATE 06/24/04	Tyco Electronics Corporation Menlo Park, Ca 94025 	
	CHECKED		TITLE SOCKET CONNECTOR, 3 SEG, CROWNEDGE STRAIGHT, 4 PWR, 8 SIGNAL, COMPLIANT PN: 284-0112-11300	
	APPROVED		SIZE B	DWG NUMBER C = 6651290
	APPROVED D. CHAU	06/25/04	REV. A1	
	DCA APPROVED M. ALIM	07/21/04		
	ACAD FILE NUMBER C6651290A.DWG	DWG SCALE 2=1		SH 3 OF 5

This drawing involves proprietary design rights of Tyco Electronics Corporation, and all design, manufacture, reproduction, use and sale rights regarding the same are expressly reserved. It is submitted for a specific purpose and the recipient by accepting this drawing, assumes custody and control and agrees to take reasonable precautions; (a) that this drawing will not be copied and reproduced, in whole or in part, or its contents revealed in any manner, or to any person except to meet the purpose for which it was delivered and (b) that any special features peculiar to this design will not be incorporated in other projects without the expressed written permission of Tyco Electronics Corporation.

REVISIONS			
EC	REV	DESCRIPTION	DATE
		SEE SHEET 1	

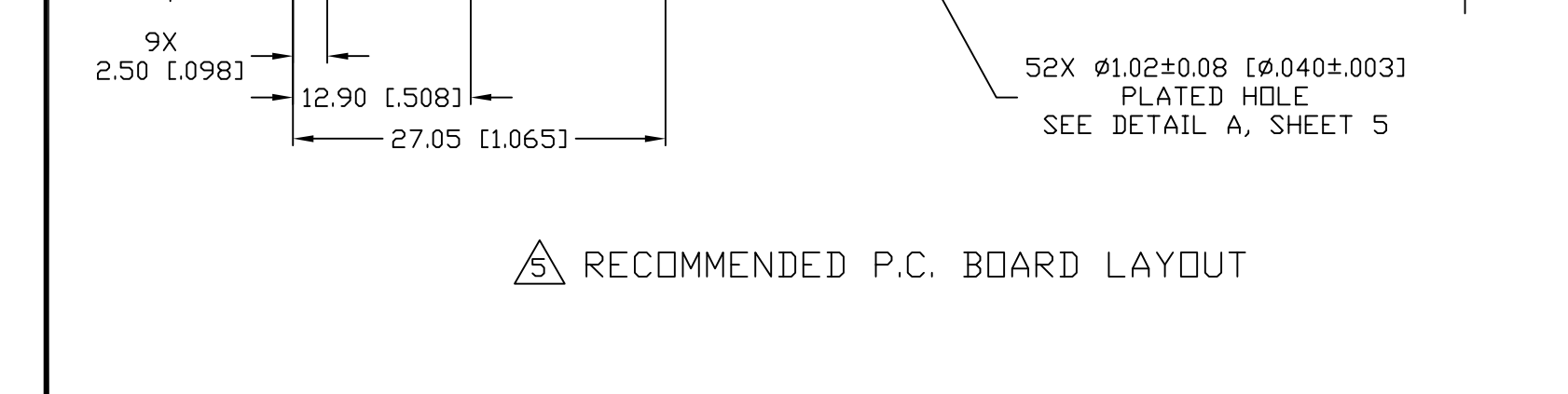
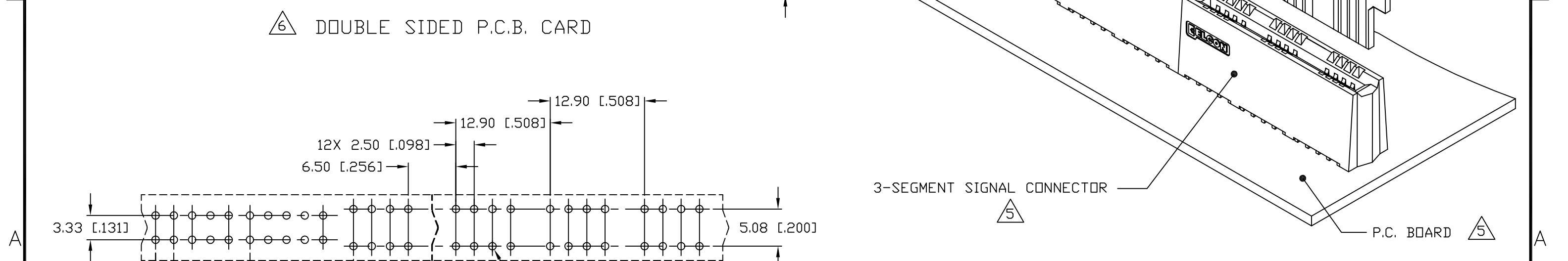
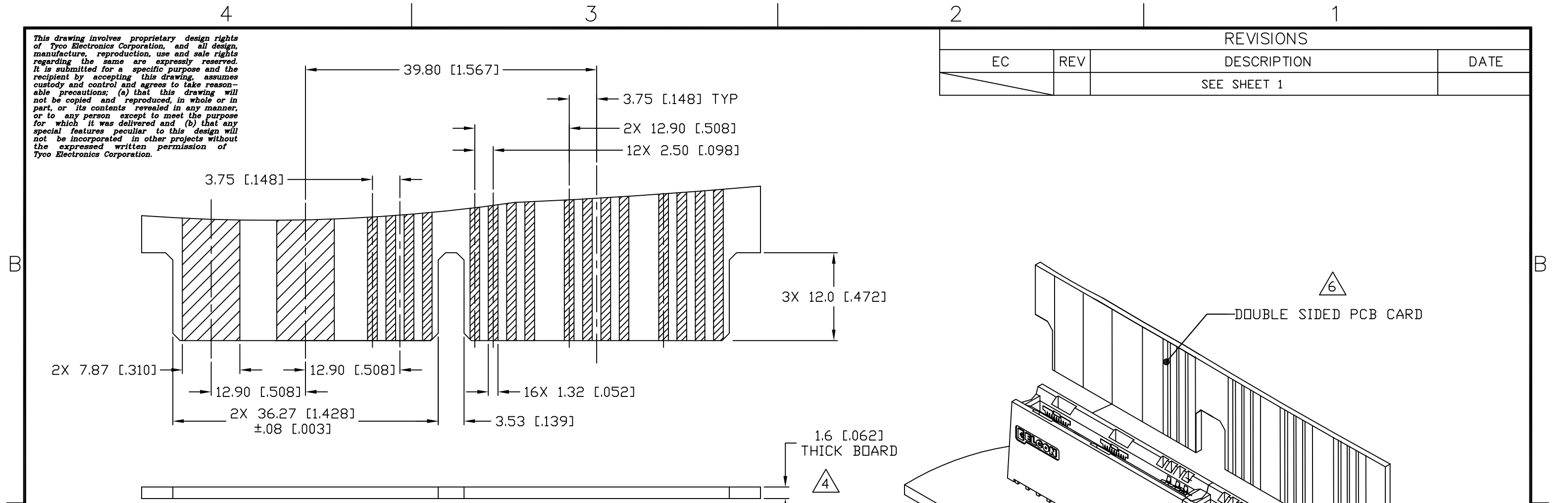

← MM OR MM [INCH] THIRD ANGLE PROJECTION UNLESS OTHERWISE SPECIFIED DIMENSIONS ARE IN METRIC [INCHES] TOLERANCES ANGLES ± .5° DECIMALS .XX ± .25 [.010] .X ± .5 [.020]	DRAWN	DATE	Tyco Electronics Corporation Menlo Park, Ca 94025	
	HA NGUYEN	06/24/04		
	CHECKED		TITLE USER INFORMATION RECOMMENDED PC BOARD LAYOUT CROWNEDGE	
	APPROVED			
	APPROVED	DATE	SIZE	DWG NUMBER
	D. CHAU	06/25/04	B	C = 6651290
	DCA APPROVED	07/21/04		REV. A1
	M. ALIM			
	ACAD FILE NUMBER	C6651290A.DWG		DWG SCALE 2=1 SH 4 OF 5

This drawing involves proprietary design rights of Tyco Electronics Corporation, and all design, manufacture, reproduction, use and sale rights regarding the same are expressly reserved. It is submitted for a specific purpose and the recipient by accepting this drawing, assumes custody and control and agrees to take reasonable precautions; (a) that this drawing will not be copied and reproduced, in whole or in part, or its contents revealed in any manner, or to any person except to meet the purpose for which it was delivered and (b) that any special features peculiar to this design will not be incorporated in other projects without the expressed written permission of Tyco Electronics Corporation.

REVISIONS			
EC	REV	DESCRIPTION	DATE
		SEE SHEET 1	

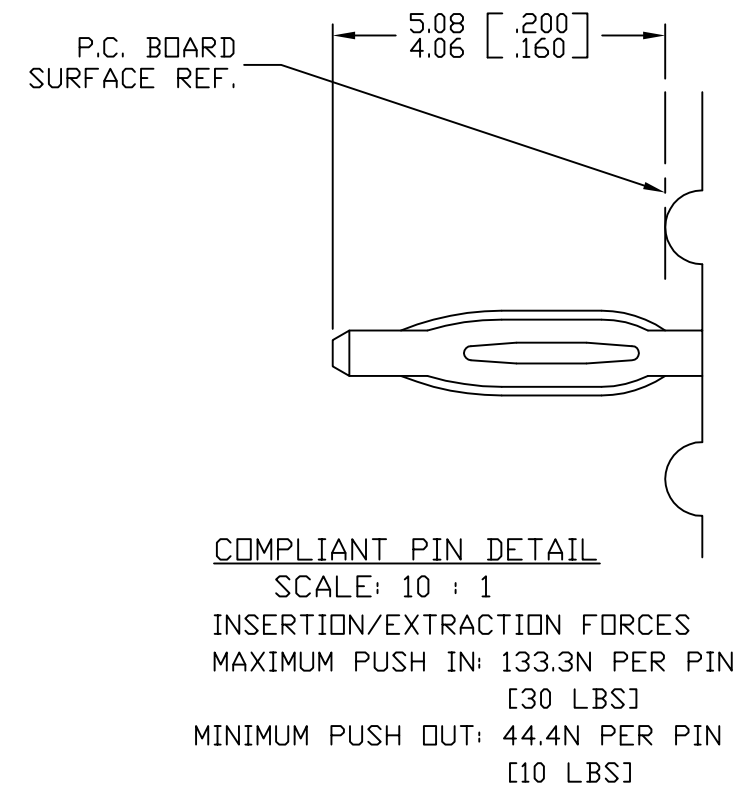
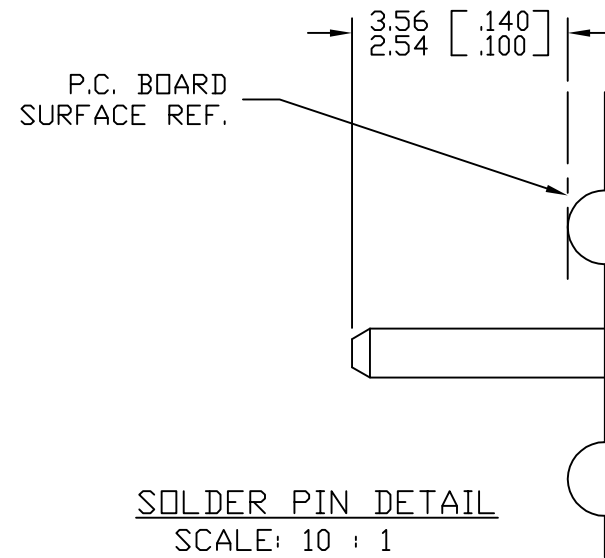
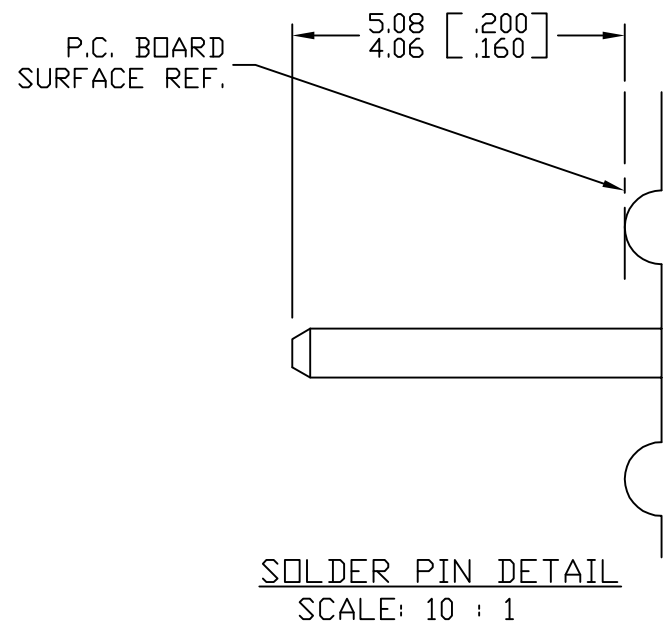

RECOMMENDED PRINTED CIRCUIT HOLE
SOLDER OR COMPLIANT PRESS FIT

FINISHED HOLE: $\phi 1.02$ [.040] ± 0.08 [.003]
DRILLED HOLE: $\phi 1.15$ [.0453] ± 0.013 [.0005]
COPPER PLATE: .025 [.0010] MINIMUM (PER SURFACE)
TIN PLATE: .008 [.0003] MINIMUM (PER SURFACE)

DETAIL A

← MM → OR MM [INCH] THIRD ANGLE PROJECTION UNLESS OTHERWISE SPECIFIED DIMENSIONS ARE IN METRIC [INCHES] TOLERANCES ANGLES $\pm .5^\circ$ DECIMALS .XX $\pm .25$ [.010] .X $\pm .5$ [.020]	DRAWN	DATE	Tyco Electronics Corporation Menlo Park, Ca 94025
	HA NGUYEN	06/24/04	
	CHECKED		
	APPROVED		
	APPROVED		TITLE
	D. CHAU	06/25/04	USER INFORMATION
	DCA APPROVED		SOLDER & COMPLIANT TERMINATION
	M. ALIM	07/21/04	CROWNEDGE
ACAD FILE NUMBER	C6651290A.DWG	SIZE	DWG NUMBER
		B	C = 6651290
			REV.
			A1
		DWG SCALE	SH 5 OF 5
		2=1	