

PRODUCT NO.

SEE SHEET 4

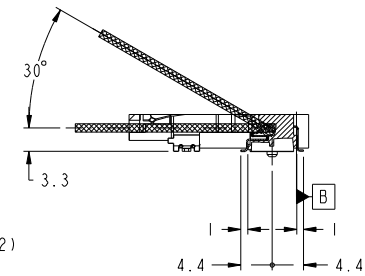

SECTION XI-XI

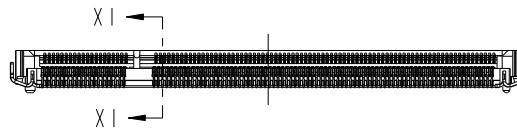
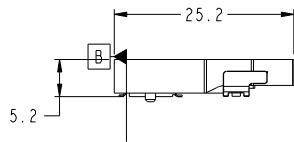
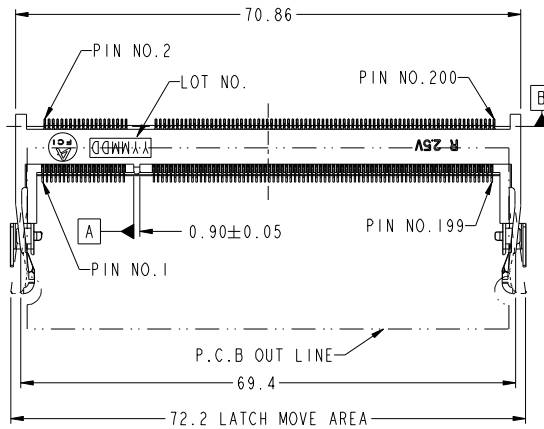
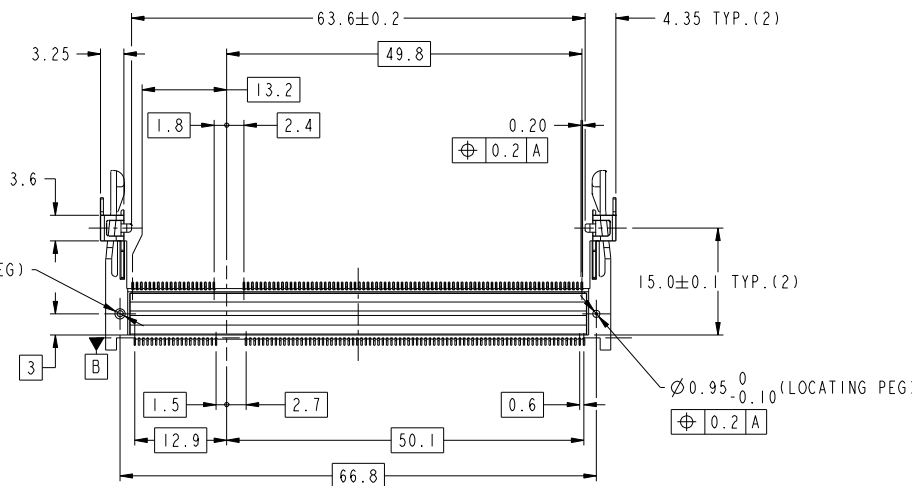

NOTE

1. PRODUCT SPEC. : GS-12-195
2. PACKAGING SPEC. : GS-14-786
3. MATERIAL:
 - 1) HOUSING : LCP, UL94V-0, COLOR BLACK
 - 2) CONTACT : COPPER ALLOY
 - 3) HOLD DOWN : BRASS
4. FINISH
 - 1) TERMINAL : SEE TABLE
 - 2) HOLD DOWN : SEE TABLE
5. CO-PLANARITY : 0.1 MAX. (INCLUDE HOLD DOWN)
6. THIS PRODUCT MEETS EUROPEAN UNION DIRECTIVES AND OTHER COUNTRY REGULATIONS AS DESCRIBED IN GS-22-008.
7. THE HOUSING WILL WITHSTAND EXPOSURE TO 260° PEAK TEMPERATURE FOR 10 SECONDS IN A REFLOW SOLDER APPLICATION.

Copyright FCI

rev	ecn no	dr	date
A	DG11-0085	SH	2011-03-30
-	-	-	-
-	-	-	-
-	-	-	-
-	-	-	-

www.fciconnect.com		surface	tolerance std	projection	MM
		ASME Y14.5	ASME Y14.5		
TOLERANCES UNLESS OTHERWISE SPECIFIED					
Dr	SH MIAO	2011-03-30	ANGULAR	0.x	±0.30
Eng	SH MIAO	2011-03-30	LINEAR	0.xx	±0.15
Chr	RICK BIAN	2011-03-30	0° ±2°	0.xxx	±0.08
Appr	HSIA JOSEPH	2011-03-30	Product family	50UF	SO-DIMM
FCI		DDR SO-DIMM 0.6mm PITCH 200 POS	Spec ref	10116657	RELEASED
REVERSE TYPE ASS'Y		catlog no	CUSTOMER COPY	sheet 1 of 4	Rev. A

PRODUCT NO.

10116657-x52xx

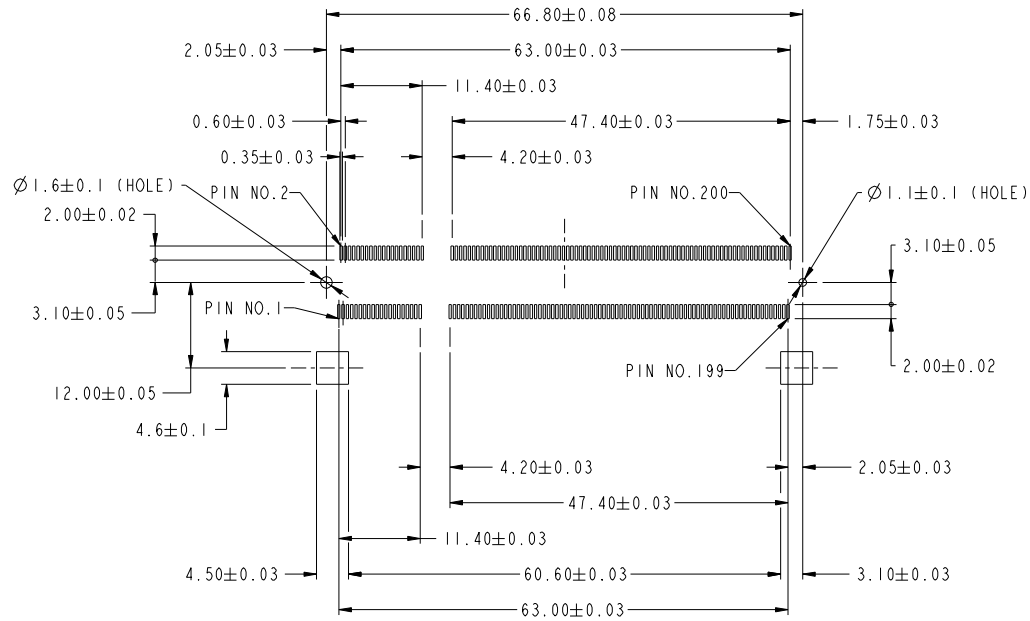

RECOMMENDED MOUNTING P.C.B. LAYOUT

Copyright FCI.
FCI

FCI	FILE	DDR SO-DIMM 0.6mm PITCH 200 POS	diag no	10116657	Rev.
	TITLE	REVERSE TYPE ASS'Y			A
	CATALOG NO		CUSTOMER COPY	sheet 2 of 4	

1		2		3		4		5		6		7		8	
PRODUCT NO.	LOCATING PEG	TERMINAL CONTACT AREA FINISH	HOLD DOWN FINISH	SOLDER TAIL FINISH											
10116657-052FS	YES	Au FLASH	Pure Sn PLATING	Au FLASH PLATING	10116657- <input type="checkbox"/> <input type="checkbox"/> <input type="checkbox"/> <input type="checkbox"/> <input type="checkbox"/> LF For Rohs OPTIONS: TAIL PLATING CODE MUST BE 0~3. HOLD DOWN PLATING CODE MUST BE "S". "LF" CODE IS EXIST IN THE END. EX: 10116657-252TSLF FOR NOT Rohs COMPATIBLE: THIS "LF" CODE IS "BLANK". EX:10116657-452TS <PACKING METHOD> R : TAPE REEL DEFAULT : TRAY <HOLD DOWN FINISH> S : Pure Sn B : Sn-Pb <CONTACT AREA FINISH> F : Au FLASH T : Au 0.3µm MIN. A : Au 0.76µm MIN. <TOTAL HEIGHT> 52 : 5.2mm <LOCATING PEG, SOLDER TAIL FINISH> 0 : YES, Au FLASH 1 : NO, Au FLASH 2 : YES, Pure Sn PLATING 3 : NO, Pure Sn PLATING 4 : YES, Sn-Pb PLATING 5 : NO, Sn-Pb PLATING										
10116657-152FS	NO														
10116657-052TS	YES	Au 0.3µm MIN.													
10116657-152TS	NO														
10116657-052AS	YES	Au 0.76µm MIN.													
10116657-152AS	NO														
10116657-052FC	YES	Au FLASH	Sn-Pb PLATING												
10116657-152FC	NO														
10116657-052TC	YES	Au 0.3µm MIN.													
10116657-152TC	NO														
10116657-052AC	YES	Au 0.76µm MIN.													
10116657-152AC	NO														
10116657-252FS	YES	Au FLASH	Pure Sn PLATING												
10116657-352FS	NO														
10116657-252TS	YES	Au 0.3µm MIN.													
10116657-352TS	NO														
10116657-252AS	YES	Au 0.76µm MIN.													
10116657-352AS	NO														
10116657-252FC	YES	Au FLASH	Sn-Pb PLATING												
10116657-352FC	NO														
10116657-252TC	YES	Au 0.3µm MIN.													
10116657-352TC	NO														
10116657-252AC	YES	Au 0.76µm MIN.													
10116657-352AC	NO														
10116657-452FS	YES	Au FLASH	Pure Sn PLATING												
10116657-552FS	NO														
10116657-452TS	YES	Au 0.3µm MIN.													
10116657-552TS	NO														
10116657-452AS	YES	Au 0.76µm MIN.													
10116657-552AS	NO														
10116657-452FC	YES	Au FLASH	Sn-Pb PLATING												
10116657-552FC	NO														
10116657-452TC	YES	Au 0.3µm MIN.													
10116657-552TC	NO														
10116657-452AC	YES	Au 0.76µm MIN.													
10116657-552AC	NO														

Copyright FCI.

	DDR SO-DIMM 0.6mm PITCH 200 POS	Rev.
	REVERSE TYPE ASS'Y	A
catalog no	10116657	sheet 4 of 4
CUSTOMER COPY		