

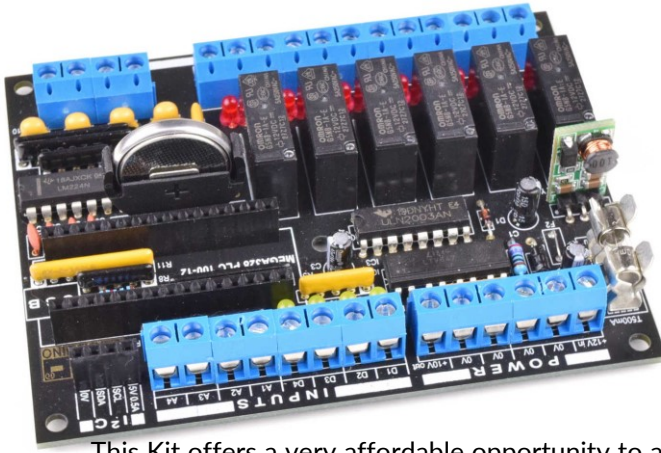

CANADUINO MEGA328 100-12 DIY PLC Kit V1



This Kit offers a very affordable opportunity to add a programmable logic controller to many kinds of projects and machines like lighting, HVAC, greenhouses, water treatment or smoke houses. It can help you control your Halloween decoration or your manufacturing equipment. The integrated and battery backed RTC allows for easy timer-controlled operation.

CANADUINO MEGA328 100-12 PLC is built around an Arduino NANO V3.0 module (or compatible) and can be programmed using Arduino IDE or visual programming using for example Mitov's awesome "Visuino" software.

CANADUINO MEGA328 100-12 PLC fits a small budget but delivers power and versatility equal to 20x more expensive professional process control devices.

MEGA328 100-12 PLC basic features:

- ✓ 4 analog 0-10V inputs (10-bit res.)
- ✓ 4 digital inputs (3-15V or 5-24V) **
- ✓ 4 analog 0-10V outputs (8-bit res.)
- ✓ 6 digital 250V/5A relay outputs
- ✓ 1 x I2C Bus
- ✓ Real-Time-Clock with battery backup

INTRODUCTION

MEGA328 100-12 PLC is a Do-It-Yourself kit comprising only through-hole parts with a pin pitch of typically 2.5mm or more and is easy to build using basic electronic tools.

There are 4 opto-isolated digital inputs, operating safely on any input voltage of 3V to 12V DC or 5V to 24V DC, depending on the hardware configuration **. The 6 digital outputs are fast acting relays OMRON G5NB-1A-E with about 10ms operate and release time, and high-capacity 5A contacts.

Analog inputs and outputs on screw terminals are designed for 0-10V operation, typically used for light dimmers but also for motor drivers, for example. A 10V voltage for example for wall dimmers is generated on the PLC module using a Zener diode and a high-power resistor and is available on the "+10V out" terminal.

Analog outputs are short circuit protected by limiting the maximum output current. Analog inputs are protected against over voltage of max. 28V.

The NANO's I2C bus is used to connect to the on-board RTC (address 0x68) and it can also be accessed through the 4-pin female header besides the analog inputs section. Since there are necessary pull-up resistors for the RTC chip already on board, external I2C devices can be connected without additional pull-up resistors.

The operation voltage for the PLC is 12V DC with a maximum current drawn of less than 500mA (typically <400mA with all relays activated).

The kit comes with screw terminals fitting wires 22-14 AWG (1.5mm max.) Four mounting holes with 3.2mm diameter are available in all 4 corners and are isolated from ground plane or any other signal. They perfectly fit 3mm standoffs or spacers if needed.

ASSEMBLING

Assembling this kit is quite easy. We expect you to have some soldering experience with thru-hole electronic components, and of course basic knowledge in analog and digital electronics, to proceed with commissioning and troubleshooting after assembling. To support your work and to make some steps easier to understand, please see the pictures on UNIVERSAL-SOLDER.com

We recommend to first solder only 1 pin of every part (2 diagonal pins on DIP ICs), flip the board and make sure the parts are nicely lined up, before soldering all remaining pins.

1. Start with the lowest profile parts R9, R10, D1 and XT1. Do not yet install R1.
2. Make your decision about the input voltage range for the digital inputs: select for R2 the 4 x 1.2k resistor if you prefer 3-15V input voltage or select 4 x 4.7k for 5-24V input voltage.
3. Proceed with the next thicker parts, until all parts are assembled. Make sure you leave 2-3mm distance to the PCB underneath of R1.
4. Finally, assemble the tall parts, like relays, voltage regulator, and battery holder.
5. Time to prepare the NANO: Solder the 2 male pin headers and **desolder LED "L"**. The ICSP header is not necessary if you want to program the controller through USB.

Hint: the fuse holder is easier to solder with the fuse already in it.

Important notes:

- ⇒ Pin 1 of the ICs is always marked with a dot or notch and is the bottom-left pin when you can read the imprint on the package.
- ⇒ Pin 1 (or common) on resistor networks is always marked with a dot and/or is the most left pin when you can read the print on the package. This pin needs to line up with the marking (filled square) on the PCB.
- ⇒ LEDs always have a long (A) and a short (K) lead. We printed the polarity on the PCB.
- ⇒ Electrolytic capacitors have [-] printed on them, and [+] is the longer lead
- ⇒ For proper operation of input D4, the LED "L" on D13 on the NANO needs to be removed.
- ⇒ The 5V DC-DC switching converter shown on the pictures was replaced by a STM L7805CV linear voltage regulator to provide better EMC and higher reliability.

COMMISSIONING

After performing visual testing for shorts or bad solder joints, start testing with a current limited voltage of not more than 12VDC, limited to 10mA, between a 0V and the “+12V in” terminal. If the current stays lower than 10mA (typically 5-7mA), and you can measure the 5V for example on IC4, pin 8, and the 10V (+/- about 0.5V) on the “+10V out” terminal, you are good to go.

Now you can insert the NANO module in the socket and load your sketch.

Please find the port mapping PLC <-> NANO in the schematics on the last page.

Important:

Do NOT supply power through USB to the NANO module as long the PLC is connected to 12V input voltage. To program your NANO module, remove it from the PLC module or turn the 12V power supply off.

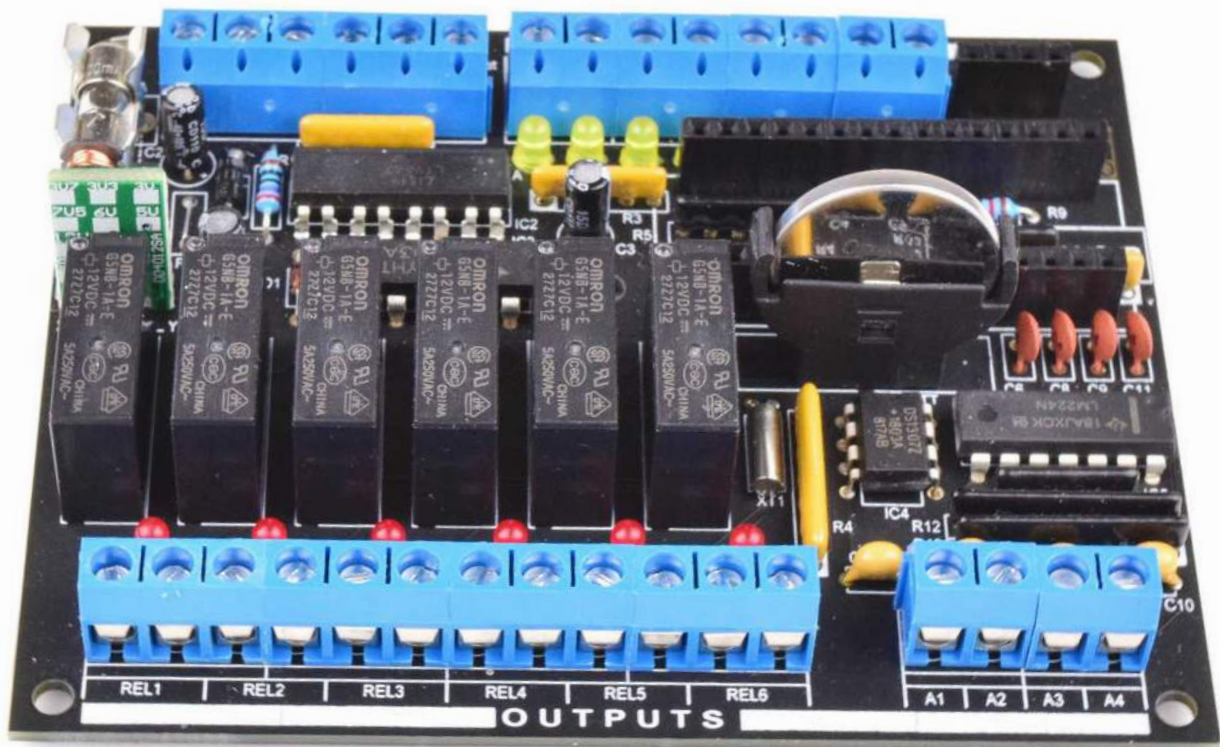

Picture shows pre-series DIY Kit, assembled. Kit is sold without CR2032 backup battery.



PARTS LIST

Quantity	Name	Value
3	C1, C2, C3	47µF 16V
4	C4, C5, C7, C10	2.2µF MLCC
4	C6, C8, C9, C11	100nF ceramic
1	D1	11V Zener diode
4	D7, D8, D10, D11	LED yellow
6	D2, D4, D5, D6, D9, D12	LED red
1	D3	1N4007
1	F1	F500mA fuse
2	F1	fuse clips 5mm
1	IC1	L7805CV
1	IC2	LTV847 opto-coupler
1	IC3	ULN2003 Darlington driver
1	IC4	DS1307 real time clock
1	IC5	LM224 op amp
1	IC6	NANO V3 (Arduino comp.)
2	IC6	female header 1x15
4	REL1 - REL6	screw terminal 3 pole
2	Power	screw terminal 3 pole
4	Inputs	screw terminal 2 pole
2	A1 - A4	screw terminal 2 pole
1	I2C	female header 1x4
6	Q1 - Q6	OMRON G5NB, 12V
1	R1	270R 1W
2	R2, R3	4x1k2 SIP5 (122) **
1	R4	6x2k2 SIP7 (222)
2	R5, R7	4x27k SIP8 (273)
2	R6, R8	4x22k SIP5 (223)
2	R9, R10	10k
1	R11	4x6k8 SIP8 (682)
1	R12	4x22k SIP8 (223)
1	R13	4x330 SIP8 (331)
1	BATT	CR2032 battery holder
1	XT1	32768kHz crystal
1	PCB	circuit board

** R2 alternative 4x4k7 - see information on page 1 and 2

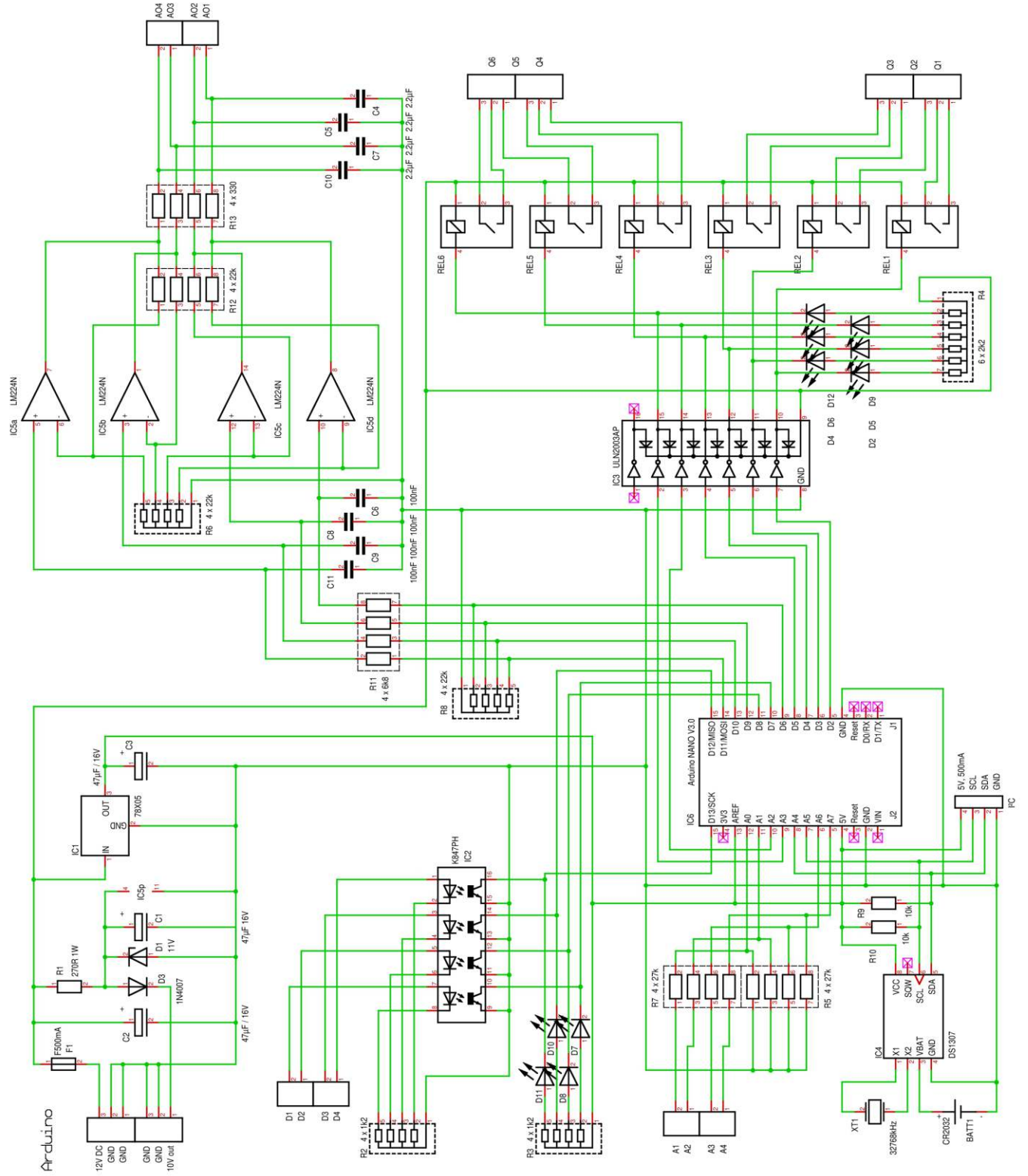

Port Matching: PLC - Arduino

Digital Inputs

- D1 - D7
- D8 - D8
- D3 - D12
- D4 - D13

Analog Inputs

- A1 - A0
- A2 - A1
- A3 - A0
- A4 - A7

Relay Outputs

- Q1 - D2
- Q2 - D3
- Q3 - D7
- Q4 - D5
- Q5 - A2
- Q6 - A3

Analog Outputs

- A01 - D6
- A02 - D9
- A03 - D10
- A04 - D11

2-Wire Interface

- SDA - A4
- SCL - A5