

PROJEKT NR.:		REVISIONS				
99-52164		ÄNDERUNGEN		DATE	DWN	APVD
P	LTR	DESCRIPTION				
		BESCHREIBUNG				
A8		NEW PACKAGING NOTE ADDED		16OCT2015	RS	R.F.
A9		MARKINGS UPDATED		01MAR2018	PK	R.F.
A10		1355082-4 OBSOLETE		21DEC2020	MKS	-
A11		1355082-2 OBSOLETE		19AUG2022	MKS	VA

POS. 1

POS. 2

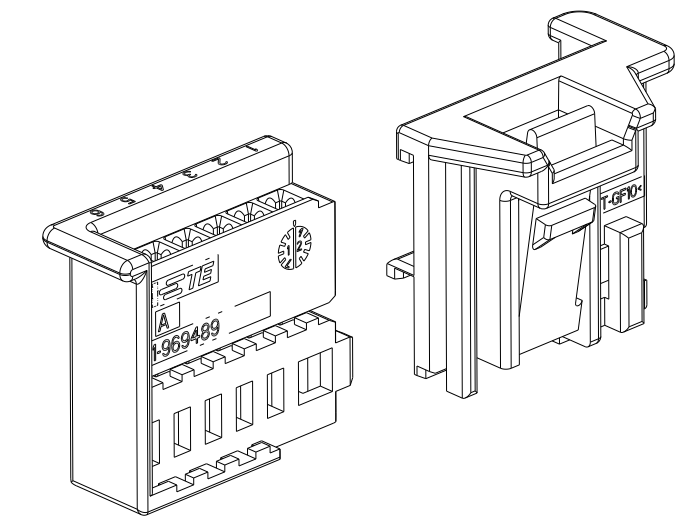
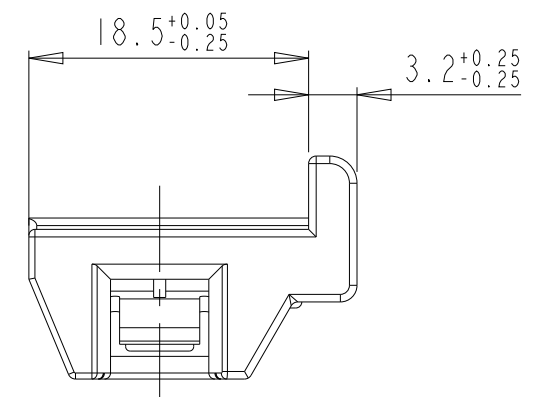
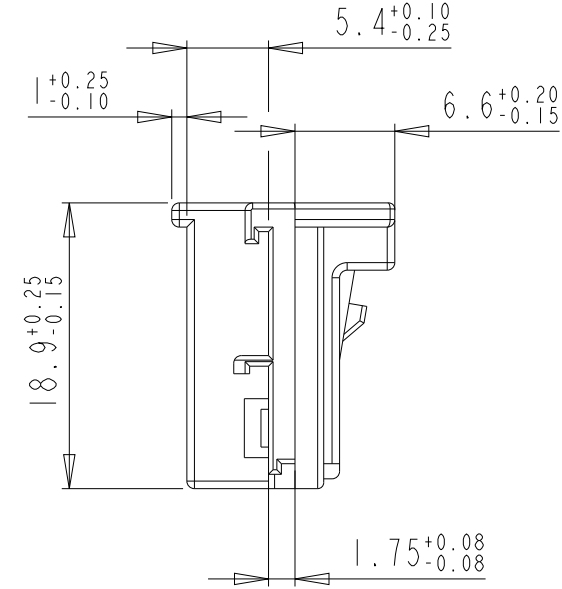
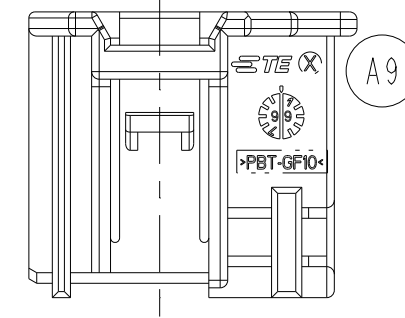
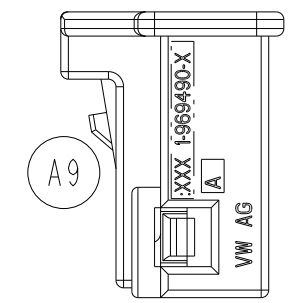
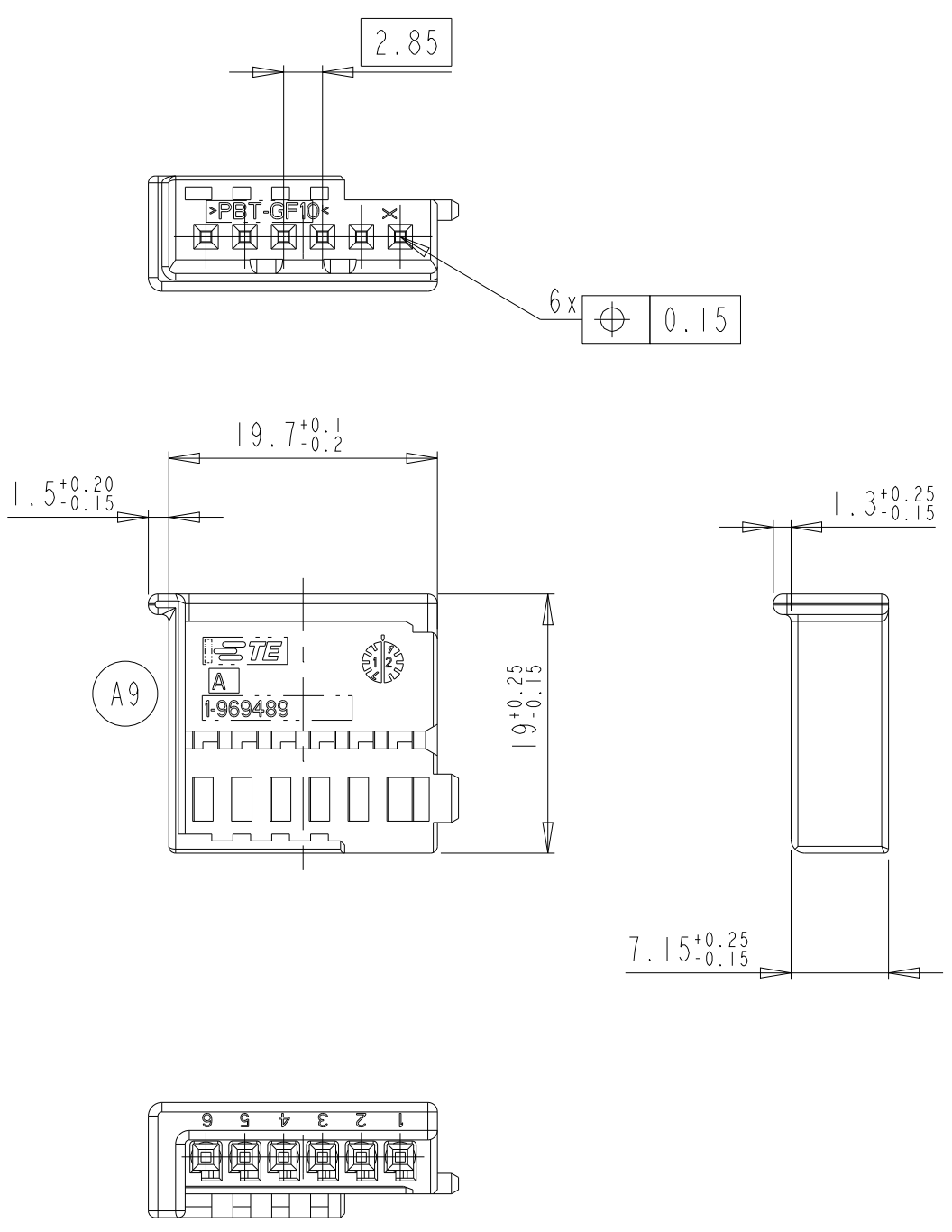

NEUTRALE VERSION

NOTES
Bemerkungen

- POS.1 SUITABLE TE SOCKET TERMINALS E.G. PN 928 999 OR 963 715
POS.1 passend mit TE-Buchsenkontakt z.B. PN 928 999 oder 963 715
- FITTING COUNTERPART ACC. DRW. 114-18601
Passender Gegenstecker nach Zeichnung 114-18601
- HOUSING AND RETAINER HAVE TO BE ORDERED SEPARATLY
PACKAGING: LOOSE PIECE IN CARDBOX
Gehäuse und Retainer müssen einzeln bestellt werden
Verpackung: Schuttgut in Karton
- MARKING DEVIATIONS AND VOID CORING POSSIBLE BECAUSE OF DIFFERENT MOLDS
Abweichende Beschriftung und Materialentnahmen auf Grund verschiedener Werkzeuge möglich

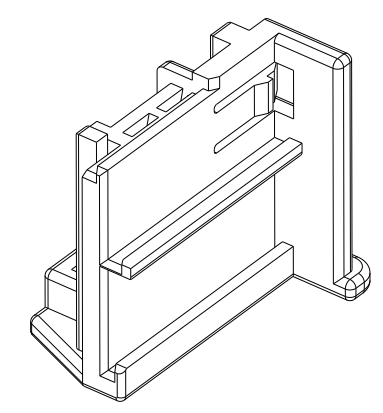
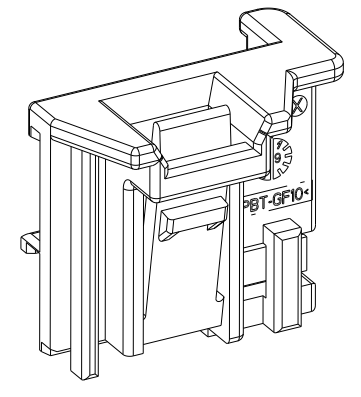
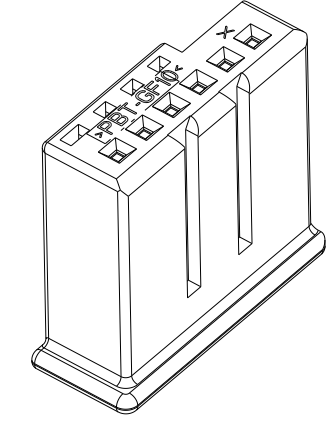
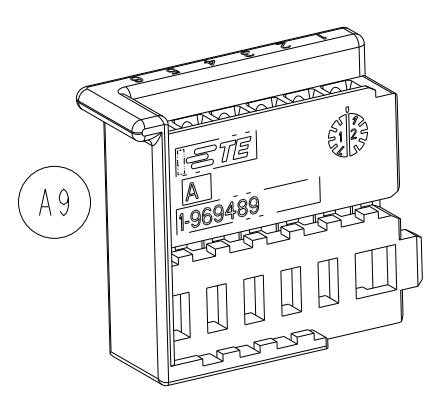

COD-ING	PART NO	REV.	MATERIAL	COLOUR SURFACE	DESCRIPTION	QTY.	ITEM NO
3	A	1355081-4	A	PBT-GF 10	BLUE	RETAINER	1 2
	A	1-969489-3	A	PBT-GF 10	WHITE	MQS-HSG, 6POSN	1 1
OBSOLETE	A	1355081-4	A	PBT-GF 10	BLUE	RETAINER	1 2
	A	1-969489-4	A	PBT-GF 10	BLUE	MQS-HSG, 6POSN	1 1
OBSOLETE	A	1355081-3	A	PBT-GF 10	WHITE	RETAINER	1 2
	A	1-969489-3	A	PBT-GF 10	WHITE	MQS-HSG, 6POSN	1 1
OBSOLETE	A	1355081-2	A	PBT-GF 10	BROWN	RETAINER	1 2
	A	1-969489-2	A	PBT-GF 10	BROWN	MQS-HSG, 6POSN	1 1
3	A	1355081-1	A	PBT-GF 10	BLACK	RETAINER	1 2
	A	1-969489-1	A	PBT-GF 10	BLACK	MQS-HSG, 6POSN	1 1

THIS DRAWING IS A CONTROLLED DOCUMENT.
 DIESES ZEICHNUNGSDOKUMENT WIRD DURCH AMP INCORPORATED KONTROLLIERT.
 ÄNDERUNGEN, DIE DEM TECHNISCHEN FORTSCHRITT DIENEN, SIND VORBEHALTEN.
 DEN JEWELIS LETZTGEHTIGEN ÄNDERUNGSSTAND ERFAHREN SIE AUF ANFRAGE.

DWN: J. Schneider 29-JUN-1999
 CHK: R. Forcitt 29-JUN-1999

APVD: -

NAME: MICRO QUADLOK SOCKET-HSG., 6POSN. + RETAINER (KIT)
 MQS-Buchsengeh., 6pol+Retainer (Kit)

SIZE: A2
 CAGE CODE: -
 DRAWING NO: C-1355082
 RESTRICTED TO: NUR FUER -

MATERIAL: -
 FINISH/OBERFLÄCHE/FARBE: -

TOLERANCES UNLESS OTHERWISE SPECIFIED:
 ALLGEMEINTOLERANZEN:
 1 PLC ± ACC. TO DIN 16901-140
 2 PLC ± CENTRIC TO NOMINAL DIM
 3 PLC ±
 4 PLC ±
 ANGLES/WINKEL ±2°
 FINISH/OBERFLÄCHE/FARBE: -

PRODUCT SPEC: -
 VERARBEITUNGSSPEZ.: -
 WEIGHT: -
 GEWICHT: -

Customer Drawing /KUNDENZEICHNUNG
 SCALE MASSSTAB: 2:1
 SHEET OF: 1
 REV: A11

STE TE Connectivity