



GENERAL DESCRIPTION

The AK4353 is a stereo CMOS D/A Converter and Digital Audio Interface Transmitter. The DAC signal outputs are single-ended and are analog filtered to remove out of band noise. Therefore no external filters are required. The AK4353 can operate at the power supply from 2.7V to 5.5V and the digital I/F can correspond to both TTL and CMOS levels.

FEATURES

- Stereo $\Delta\Sigma$ DAC**
- S/(N+D): 90dB@5V**
- DR: 102dB@5V**
- S/N: 102dB@5V**
- Sampling Speed: 16kHz~96kHz**
- Multiple Master Clock Frequencies:**

256fs/384fs/512fs/768fs/1024fs/1536fs	for Half speed (16kHz~24kHz)
256fs/384fs/512fs/768fs	for Normal speed (32kHz~48kHz)
128fs/192fs/256fs/384fs	for Double speed (64kHz~96kHz)
- Data Input Formats:**
LSB justified / MSB justified / I²S selectable
- Selectable Function:**
 - Soft Mute
 - Digital Attenuator (256 Steps)
 - Digital De-emphasis (44.1kHz/48kHz/32kHz)
- Output Mode: Stereo, Mono, Reverse, Mute**
- On-Chip Digital Audio Interface Transmitter:**
Compatible with S/PDIF, IEC958, AES/EBU & EIAJ CP1201 consumer mode
- Input Level: TTL/CMOS Selectable**
- Output Level: 3.0Vpp@5V**
- Control mode: 3-wire Serial / I²C Bus**
- Low Power Dissipation: 80mW@5V**
- Small 24pin VSOP Package**
- Power Supply: 2.7~5.5V**
- Ta: -40~85°C**

■ Block Diagram

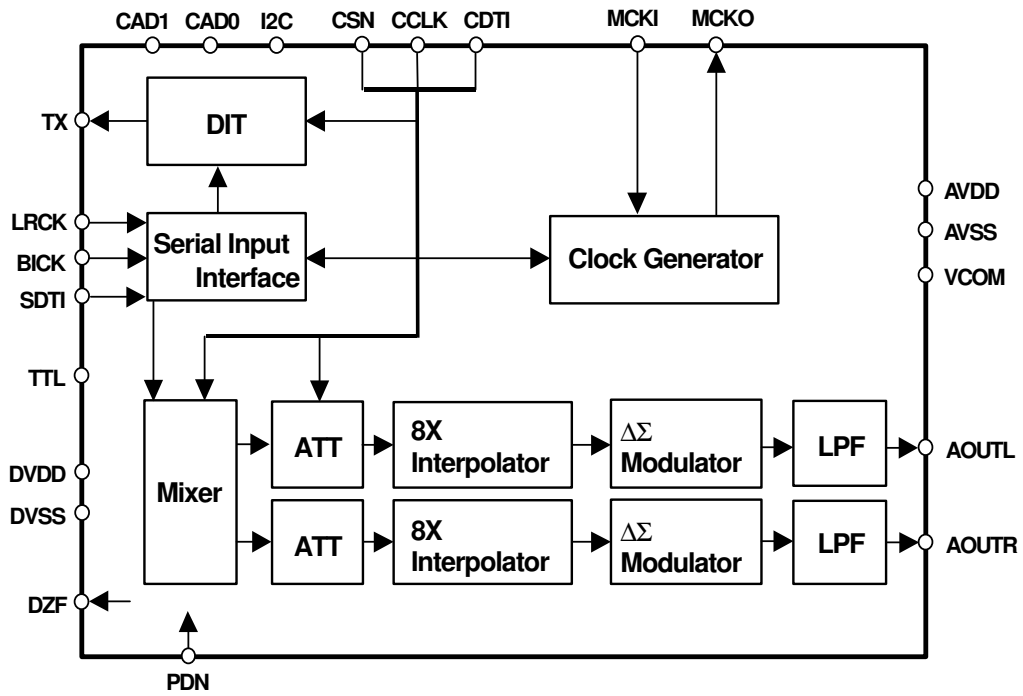

Figure 1. 3-wire Serial Control Mode (I2C = "L")

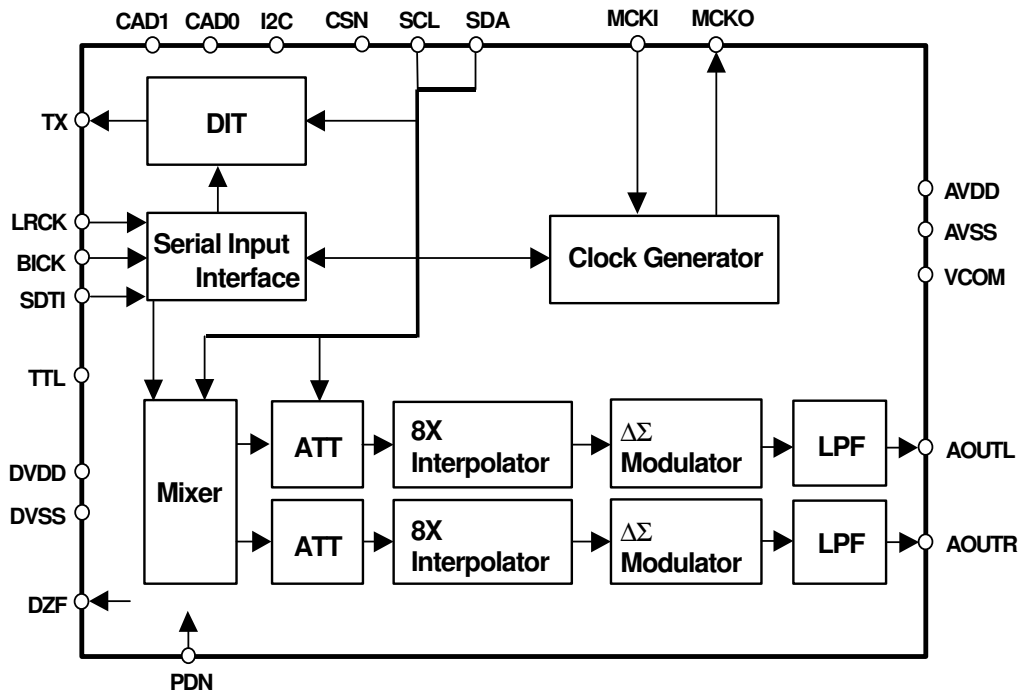

Figure 2. I²C Bus Control Mode (I2C = "H")

■ Ordering Guide

AK4353VF
AKD4353

-40~+85°C
Evaluation Board

24pin VSOP

■ Pin Layout

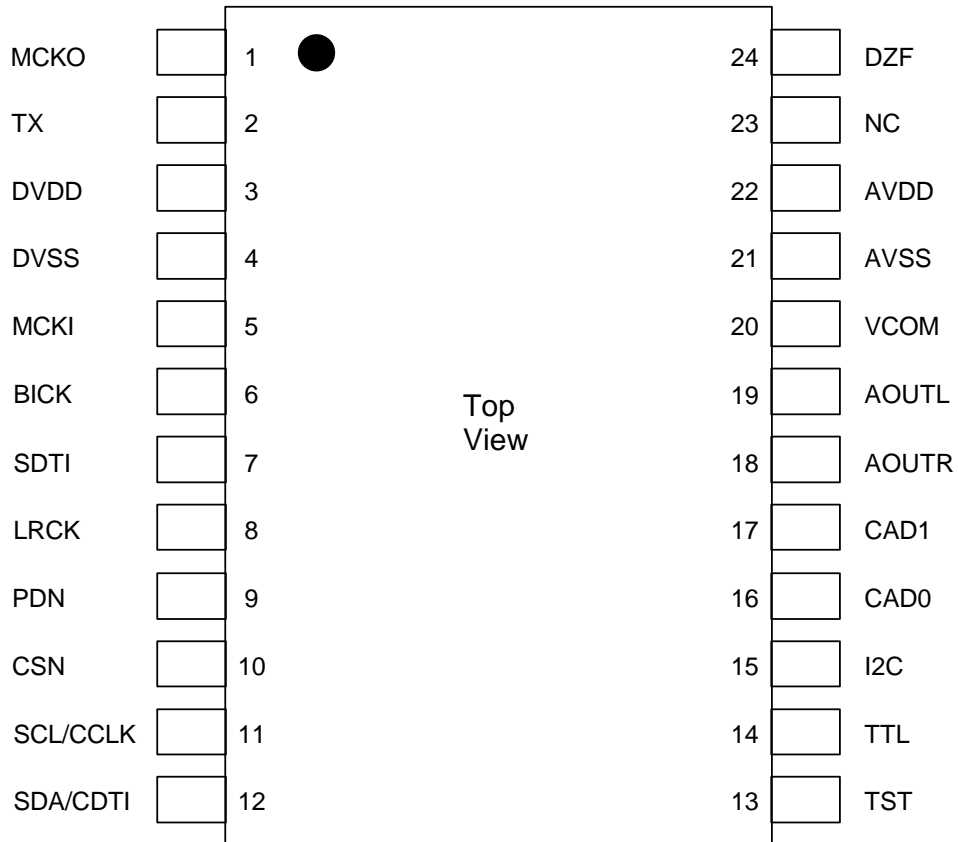

PIN/FUNCTION			
No.	Pin Name	I/O	Description
1	MCKO	O	Master Clock Output Pin Same frequency as MCKI is output
2	TX	O	Transmit Channel Output Pin
3	DVDD	-	Digital Power Supply Pin, +2.7~+5.5V
4	DVSS	-	Digital Ground Pin, 0V
5	MCKI	I	Master Clock Input Pin
6	BICK	I	Serial Data Clock Pin
7	SDTI	I	Serial Data Input Pin
8	LRCK	I	Serial Input Channel Clock Pin
9	PDN	I	Power-Down Pin When "L", the circuit is in power-down mode. The AK4353 should always be reset upon power-up.
10	CSN	I	Chip Select Pin at 3-wire Serial control mode This pin should be connected to DVDD at I ² C Bus control mode.
11	SCL	I	Control Clock Pin at I ² C bus control mode
	CCLK	I	Control Clock Pin at 3-wire serial control mode
12	SDA	I/O	Control Data Input/Output Pin at I ² C Bus control mode
	CDTI	I	Control Data Input Pin at 3-wire serial control mode
13	TST	I	Test pin This pin should be connected to DVDD.
14	TTL	I	Digital Input Level Select Pin "L": CMOS, "H": TTL
15	I2C	I	Control Mode Select Pin "L": 3-wire Serial, "H": I ² C Bus
16	CAD0	I	Chip Address Select 0 Pin
17	CAD1	I	Chip Address Select 1 Pin
18	AOUTR	O	Rch Analog Output Pin
19	AOUTL	O	Lch Analog Output Pin
20	VCOM	O	Common Voltage Output Pin, AVDD/2 Used for analog common voltage. Large external capacitor is used to reduce power supply noise.
21	AVSS	-	Analog Ground Pin
22	AVDD	-	Analog Power Supply Pin
23	NC	-	No Connect Nothing should be connected externally to this pin.
24	DZF	O	Zero Input Detect Pin When SDTI follows a total 8192 LRCK cycles with "0" input data or RSTN = "0", this pin goes to "H".

Note: No input pins should be left floating.

ABSOLUTE MAXIMUM RATINGS

(AVSS, DVSS=0V; Note 1)

Parameter		Symbol	min	max	Units
Power Supplies	Analog	AVDD	-0.3	6.0	V
	Digital	DVDD	-0.3	6.0	V
	AVSS-DVSS (Note 2)	Δ GND	-	0.3	V
Input Current (any pins except for supplies)		IIN	-	\pm 10	mA
Analog Input Voltage		VINA	-0.3	AVDD+0.3	V
Digital Input Voltage		VIND	-0.3	DVDD+0.3	V
Ambient Temperature		Ta	-40	85	°C
Storage Temperature		Tstg	-65	150	°C

Note: 1. All voltages with respect to ground.

2. AVSS and DVSS must be connected to the same analog ground plane.

WARNING: Operation at or beyond these limits may results in permanent damage to the device.

Normal operation is not guaranteed at these extremes.

RECOMMENDED OPERATING CONDITIONS

(AVSS, DVSS=0V; Note 1)

Parameter		Symbol	min	typ	max	Units
Power Supplies (Note 3)	3V operation (TTL = "L")					
	Analog	AVDD	2.7	3.0	5.5	V
	Digital	DVDD	2.7	3.0	3.6 or AVDD	V
	5V operation (TTL = "H")					
	Analog	AVDD	4.5	5.0	5.5	V
	Digital	DVDD	4.5	5.0	AVDD	V

Note: 1. All voltages with respect to ground.

3. The power up sequence between AVDD and DVDD is not critical.

*AKM assumes no responsibility for the usage beyond the conditions in this datasheet.

ANALOG CHARACTERISTICS (fs=44.1kHz)

(Ta=25°C; AVDD, DVDD=5V; fs=44.1kHz; DFS1-0 = "00"; CKS2-0 = "000"; DIF2-0 = "101";
Signal Frequency =1kHz; Measurement frequency=20Hz~20kHz; unless otherwise specified)

Parameter		min	typ	max	Units
Dynamic Characteristics					
Resolution				24	Bits
S/(N+D)	AVDD=5V	84	90		dB
	AVDD=3V	80	86		dB
DR (-60dB input, A-weighted)	AVDD=5V	94	102		dB
	AVDD=3V	90	97		dB
S/N (A-weighted)	AVDD=5V	94	102		dB
	AVDD=3V	90	97		dB
Interchannel Isolation		90	110		dB
DC Accuracy					
Interchannel Gain Mismatch			0.2	0.5	dB
Gain Drift			20	-	ppm/°C
Output Voltage AOUT=0.6x(AVDD-AVSS)	AVDD=5V	2.8	3.0	3.2	Vpp
	AVDD=3V	1.66	1.8	1.94	Vpp
Load Resistance (Note 4)		10			kΩ
Load Capacitance				25	pF
Power Supplies					
Power Supply Current					
Normal Operation (PDN = "H")					
AVDD			8	12	mA
DVDD (Note 5)			8	16	mA
Power-Down-Mode (PDN = "L")					
AVDD+DVDD			10	100	μA

Note:4. AC load.

5. DVDD drops to 4mA at DVDD=3V.

ANALOG CHARACTERISTICS (fs=96kHz)

(Ta=25°C; AVDD, DVDD=5V; fs=96kHz; DFS1-0 = "01"; CKS2-0 = "001"; DIF2-0 = "101";
Signal Frequency =1kHz; Measurement frequency=20Hz~40kHz; unless otherwise specified)

Parameter		min	typ	max	Units
Dynamic Characteristics					
Resolution				24	Bits
S/(N+D)	AVDD=5V	80	86		dB
	AVDD=3V	78	84		dB
DR (-60dB input)	AVDD=5V	88	96		dB
	AVDD=3V	84	92		dB
S/N	AVDD=5V	88	96		dB
	AVDD=3V	84	92		dB
Interchannel Isolation		90	110		dB
DC Accuracy					
Interchannel Gain Mismatch			0.2	0.5	dB
Gain Drift			20	-	ppm/°C
Output Voltage AOUT=0.6x(AVDD-AVSS)	AVDD=5V	2.8	3.0	3.2	Vpp
	AVDD=3V	1.66	1.8	1.94	Vpp
Load Resistance (Note 4)		10			kΩ
Load Capacitance				25	pF
Power Supplies					
Power Supply Current					
Normal Operation (PDN = "H")	AVDD	(Note 6)	8	12	mA
	DVDD		13	26	mA
Power-Down-Mode (PDN = "L")	AVDD+DVDD		10	100	μA

Note:4. AC load.

6. DVDD drops to 7mA at DVDD=3V.

FILTER CHARACTERISTICS (fs=44.1kHz)

(Ta=25°C; AVDD, DVDD=2.7~5.5V; fs=44.1kHz; DEM=OFF)

Parameter	Symbol	min	typ	max	Units	
Digital Filter						
Passband (Note 7)		-0.02dB	PB	0	20.0	kHz
		-6.0dB		-	22.05	kHz
Stopband (Note 7)	SB	24.1			kHz	
Passband Ripple	PR			±0.02	dB	
Stopband Attenuation	SA	54			dB	
Group Delay (Note 8)	GD	-	20.1	-	1/fs	
Digital Filter + Analog Filter						
Frequency Response: 0~20.0kHz	FR	-	±0.2	-	dB	

Note:7. The passband and stopband frequencies scale with fs.

For example, PB=0.4535*fs(@±0.02dB), SB=0.546*fs.

8. The calculating delay time which occurred by digital filtering. This time is from setting the 24bit data of both channels on the input register to the output of analog signal.

FILTER CHARACTERISTICS (fs=96kHz)

(Ta=25°C; AVDD, DVDD=2.7~5.5V; fs=96kHz; DEM=OFF)

Parameter	Symbol	min	typ	max	Units	
Digital Filter						
Passband (Note 7)		-0.02dB	PB	0	43.5	kHz
		-6.0dB		-	48.0	kHz
Stopband (Note 7)	SB	52.5			kHz	
Passband Ripple	PR			±0.02	dB	
Stopband Attenuation	SA	54			dB	
Group Delay (Note 8)	GD	-	20.1	-	1/fs	
Digital Filter + Analog Filter						
Frequency Response: 0~20.0kHz	FR	-	±0.2	-	dB	
40.0kHz		-	±0.2	-	dB	

Note:7. The passband and stopband frequencies scale with fs.

For example, PB=0.4535*fs(@±0.02dB), SB=0.546*fs.

8. The calculating delay time which occurred by digital filtering. This time is from setting the 24bit data of both channels on the input register to the output of analog signal.

DIGITAL CHARACTERISTICS (CMOS level input)

(Ta=25°C; AVDD=2.7~5.5V; DVDD=2.7~3.6V; TTL = "L")

Parameter	Symbol	min	typ	max	Units
High-Level Input Voltage	VIH	0.7xDVDD	-	-	V
Low-Level Input Voltage	VIL	-	-	0.3xDVDD	V
High-Level Output Voltage					
(TX, MCKO pins: Iout=-100μA)	VOH	DVDD-0.5	-	-	V
(DZF pin: Iout=-100μA)	VOH	AVDD-0.5	-	-	V
Low-Level Output Voltage					
(TX, MCKO, DZF pins: Iout= 100μA)	VOL	-	-	0.5	V
(SDA pin: Iout= 3mA)	VOL	-	-	0.4	V
Input Leakage Current	Iin	-	-	±10	μA

DIGITAL CHARACTERISTICS (TTL level input; except for TTL pin)

(Ta=25°C; AVDD, DVDD=4.5~5.5V; TTL = "H")

Parameter	Symbol	min	typ	max	Units
High-Level Input Voltage					
(TTL pin)	VIH	0.7xDVDD	-	-	V
(All pins except for TTL pin)	VIH	2.2	-	-	V
Low-Level Input Voltage					
(TTL pin)	VIL	-	-	0.3xDVDD	V
(All pins except for TTL pin)	VIL	-	-	0.8	V
High-Level Output Voltage					
(TX, MCKO pins: Iout=-100μA)	VOH	DVDD-0.5	-	-	V
(DZF pin: Iout=-100μA)	VOH	AVDD-0.5	-	-	V
Low-Level Output Voltage					
(TX, MCKO, DZF pins: Iout= 100μA)	VOL	-	-	0.5	V
(SDA pin: Iout= 3mA)	VOL	-	-	0.4	V
Input Leakage Current	Iin	-	-	±10	μA

SWITCHING CHARACTERISTICS

(Ta=25°C; AVDD, DVDD=2.7~5.5V; CL=20pF)

Parameter	Symbol	min	typ	max	Units
Master Clock Input:					
Frequency					
128fs/256fs/512fs/1024fs	fCLK	4.096		24.576	MHz
192fs/384fs/768fs/1536fs	fCLK	6.144		36.864	MHz
Duty Cycle	dCLK	40		60	%
LRCK: (Note 9)					
Frequency					
Half Speed Mode (DFS1-0 = "11")	fsh	16		24	kHz
Normal Speed Mode (DFS1-0 = "00")	fsn	32		48	kHz
Double Speed Mode (DFS1-0 = "01")	fsd	64		96	kHz
Duty Cycle	Duty	45		55	%
Serial Interface Timing:					
BICK Period					
Half Speed Mode	tBCK	1/128fs			ns
Normal Speed Mode	tBCK	1/128fs			ns
Double Speed Mode	tBCK	1/64fs			ns
BICK Pulse Width Low	tBCKL	70			ns
BICK Pulse Width High	tBCKH	70			ns
BICK "↑" to LRCK Edge (Note 10)	tBLR	40			ns
LRCK Edge to BICK "↑" (Note 10)	tLRB	40			ns
SDTI Hold Time	tSDH	40			ns
SDTI Setup Time	tSDS	40			ns
Power-down & Reset Timing					
PDN Pulse Width (Note 11)	tPDW	150			ns

Note: 9. If sampling speed mode (DFS0-1) changes, please reset by PDN pin or RSTN bit.

10. BICK rising edge must not occur at the same time as LRCK edge.

11. The AK4353 can be reset by PDN pin "L" upon power up.

If CKS0-2 or DFS0-1 changes, the AK4353 should be reset by PDN pin or RSTN bit.

Parameter	Symbol	min	typ	max	Units
Control Interface Timing (3-wire Serial mode):					
CCLK Period	tCCK	200			ns
CCLK Pulse Width Low	tCCKL	80			ns
Pulse Width High	tCCKH	80			ns
CDTI Setup Time	tCDS	40			ns
CDTI Hold Time	tCDH	40			ns
CSN "H" Time	tCSW	150			ns
CSN "↓" to CCLK "↑"	tCSS	50			ns
CCLK "↑" to CSN "↑"	tCSH	50			ns
Control Interface Timing (I²C Bus mode):					
SCL Clock Frequency	fSCL	-		100	kHz
Bus Free Time Between Transmissions	tBUF	4.7		-	μs
Start Condition Hold Time (prior to first clock pulse)	tHD:STA	4.0		-	μs
Clock Low Time	tLOW	4.7		-	μs
Clock High Time	tHIGH	4.0		-	μs
Setup Time for Repeated Start Condition	tSU:STA	4.7		-	μs
SDA Hold Time from SCL Falling (Note 12)	tHD:DAT	0		-	μs
SDA Setup Time from SCL Rising	tSU:DAT	0.25		-	μs
Rise Time of Both SDA and SCL Lines	tR	-		1.0	μs
Fall Time of Both SDA and SCL Lines	tF	-		0.3	μs
Setup Time for Stop Condition	tSU:STO	4.0		-	μs
Pulse Width of Spike Noise Suppressed by Input Filter	tSP	0		50	ns

Note: 12. Data must be held for sufficient time to bridge the 300 ns transition time of SCL.

■ Timing Diagram

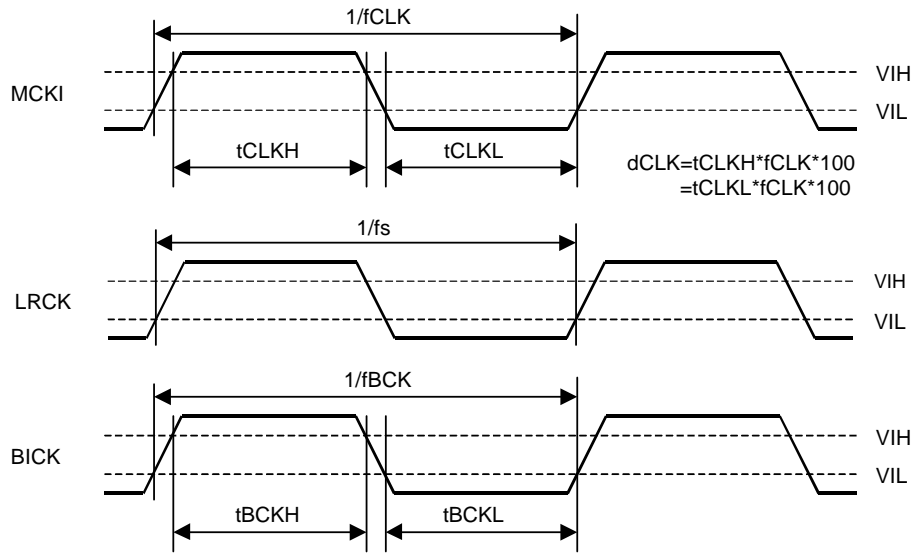

Clock Timing

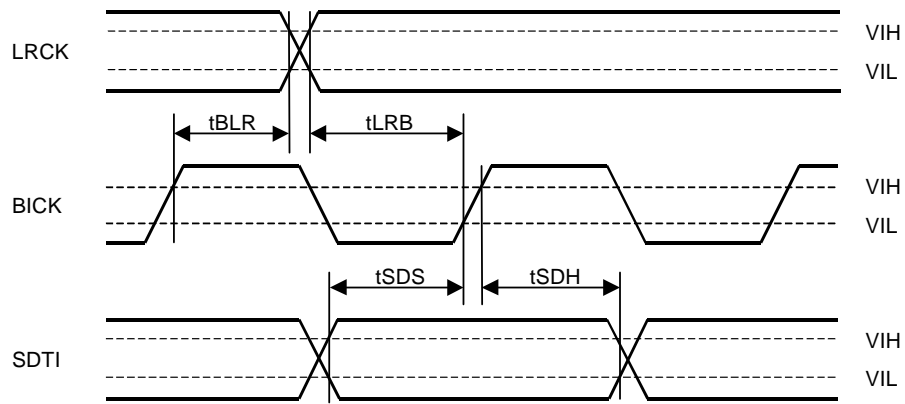

Serial Interface Timing

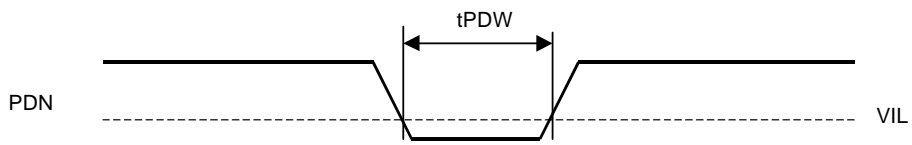

Power-down & Reset Timing

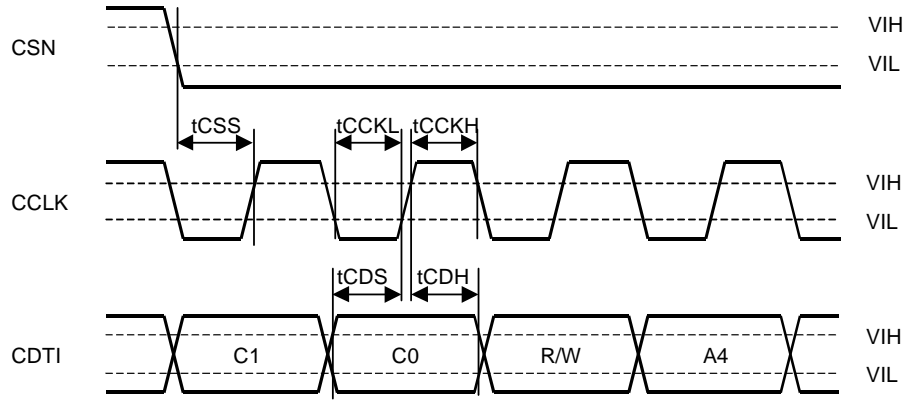

WRITE Command Input Timing (3-wire Serial mode)

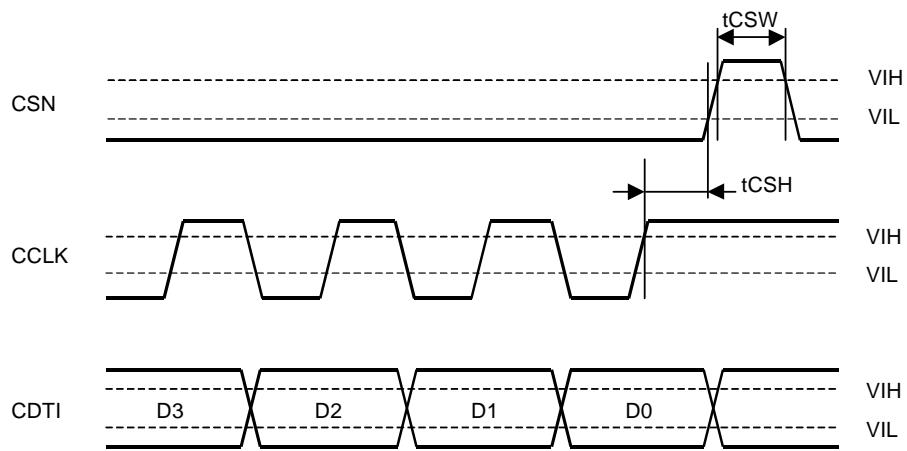

WRITE Data Input Timing (3-wire Serial mode)

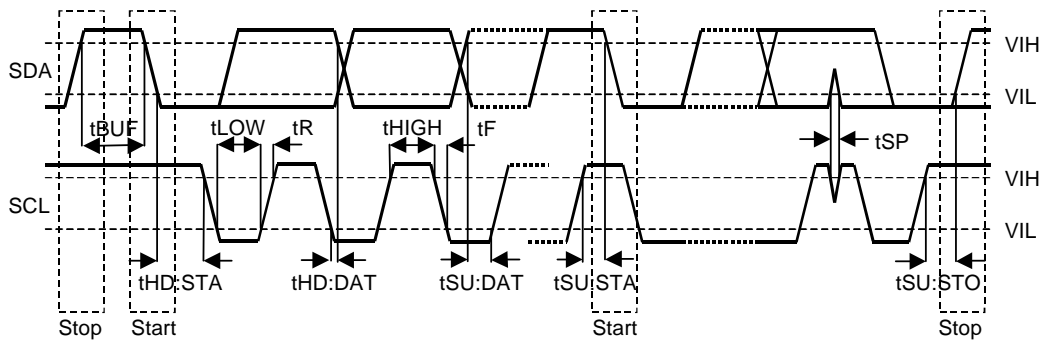

I²C Bus mode Timing

OPERATION OVERVIEW

■ System Clock Input

The external clocks which are required to operate the AK4353 are MCKI, LRCK and BICK. The master clock (MCKI) should be synchronized with sampling clock (LRCK) but the phase is not critical. MCKI is used to operate the digital interpolation filter and the delta-sigma modulator. The frequency of MCKI can be set by CKS2-0, and can be selected to half, normal or double speed mode by DFS1-0 (See Table 1).

All external clocks (MCKI,BICK,LRCK) should always be present whenever the AK4353 is in the normal operation mode (PDN = "H"). If these clock are not provided, the AK4353 may draw excess current and may not possibly operate properly because the device utilizes dynamic refreshed logic internally. If the external clocks are not present, the AK4353 should be in the power-down mode (PDN = "L") or in the reset mode (RSTN = "0"). After exiting reset at power-up etc., the AK4353 is in the power-down mode until MCKI and LRCK are input.

When the register data of CKS2-0 or DFS1-0 is changed during normal operation, the AK4353 should be reset by PDN pin "L" or RSTN bit "0".

CKS2	CKS1	CKS0	DFS1-0		
			"11" (Half speed)	"00" (Normal speed)	"01" (Double speed)
0	0	0	512fs	256fs	128fs
0	0	1	256fs	256fs	256fs
0	1	0	768fs	384fs	192fs
0	1	1	384fs	384fs	384fs
1	0	0	1024fs	512fs	256fs
1	0	1	512fs	512fs	N/A
1	1	0	1536fs	768fs	384fs
1	1	1	768fs	768fs	N/A

default (DFS1-0 = "00")

Table 1. System Clock (DFS1-0="10": reserved)

fs [kHz]	Mode	128fs	192fs	256fs	384fs	512fs	768fs	1024fs	1536fs
16	Half	-	-	4.0960	6.1440	8.1920	12.2880	16.3840	24.5760
32	Normal	-	-	8.1920	12.2880	16.3840	24.5760	-	-
64	Double	8.1920	12.2880	16.3840	24.5760	-	-	-	-
22.05	Half	-	-	5.6448	8.4672	11.2896	16.9344	22.5792	33.8688
44.1	Normal	-	-	11.2896	16.9344	22.5792	33.8688	-	-
88.2	Double	11.2896	16.9344	22.5792	33.8688	-	-	-	-
24	Half	-	-	6.1440	9.2160	12.2880	18.4320	24.5760	36.8640
48	Normal	-	-	12.2880	18.4320	24.5760	36.8640	-	-
96	Double	12.2880	18.4320	24.5760	36.8640	-	-	-	-

Table 2. Example of System Clock [MHz]

■ Audio Serial Interface Format

Data is shifted in via the SDTI pin using BICK and LRCK inputs. 6 serial data modes are supported and selected by register data of DIF2-0 as shown in Table 3. In all modes the serial data is MSB-first, 2's compliment format and is latched on the rising edge of BICK. Mode 4 can be used for 20, 18 and 16 MSB justified formats by zeroing the unused LSBs.

Mode	DIF2	DIF1	DIF0	SDTI	L/R	BICK
0	0	0	0	16bit, LSB justified	H/L	≥32fs
1	0	0	1	18bit, LSB justified	H/L	≥36fs
2	0	1	0	20bit, LSB justified	H/L	≥40fs
3	0	1	1	24bit, LSB justified	H/L	≥48fs
4	1	0	0	24bit, MSB justified	H/L	≥48fs
5	1	0	1	I ² S	L/H	≥48fs
6	1	1	0	Reserved		
7	1	1	1	Reserved		

default

Table 3. Audio Data Format

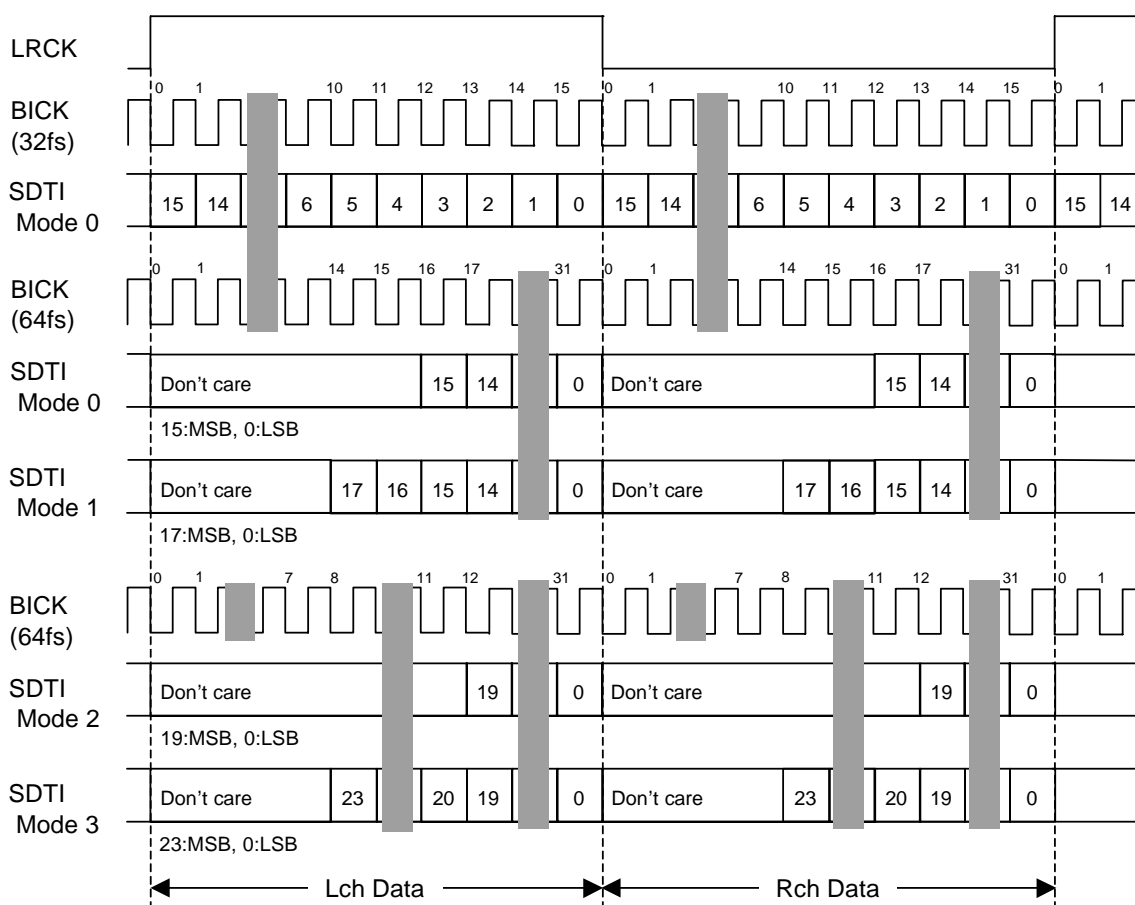

Figure 3. Mode 0-3 Timing

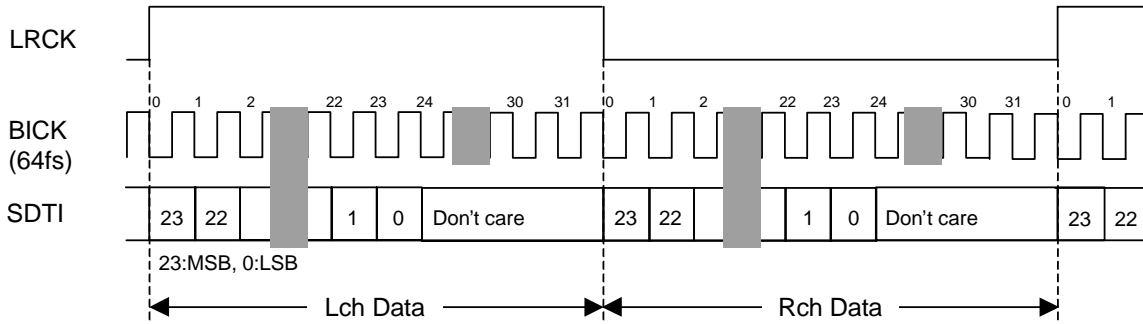

Figure 4. Mode 4 Timing

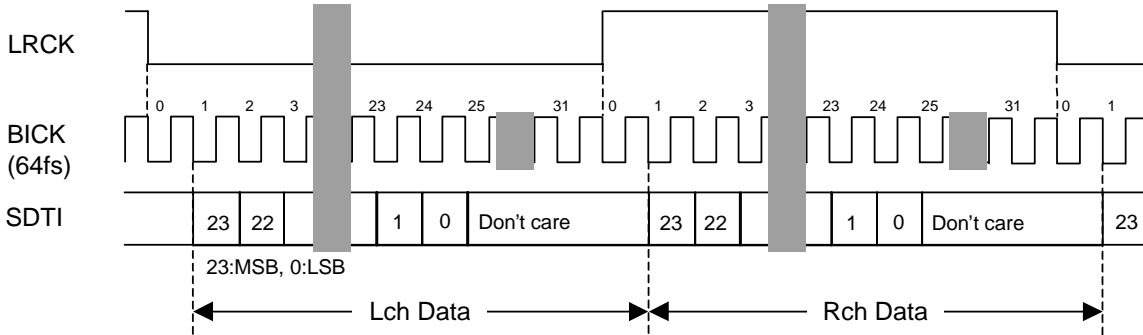

Figure 5. Mode 5 Timing

■ Data Transmission Format

Data input via SDTI pin is formatted in digital interface format and output via TX pin. Data transmitted on the TX output is formatted in blocks as shown in figure 6. Each block consists of 192 frames. A frame of data contains two sub-frames. A sub-frame consists of 32 bits of information. Each data bit received is coded using a bi-phase mark encoding as a two binary state symbol. The preambles violate bi-phase encoding so they may be differentiated from data. In bi-phase encoding, the first state of an input symbol is always the inverse of the last state of the previous data symbol. For a logic 0, the second state of the symbol is the same as the first state. For a 1, the second state is the opposite of the first. Figure 7 illustrates a sample stream of 8 data bits encoded in 16 symbol states.

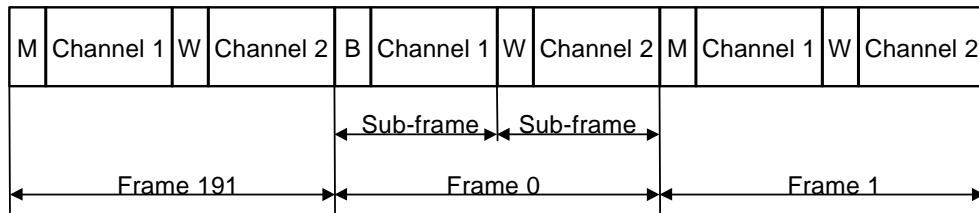

Figure 6. Block format

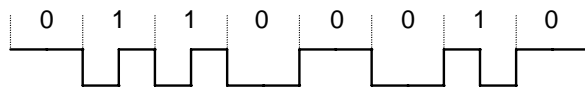

Figure 7. A biphas-encoded bit stream

The sub-frame is defined in the figure below:

- Bits 0-3 of the sub-frame represent a preamble for synchronization. There are three preambles:
 The block preamble, B, is contained in the first sub-frame of Frame 0.
 The channel 1 preamble, M, is contained in the first sub-frame of all other frames.
 The channel 2 preamble, W, is contained in all of the second sub-frames.
 Table 4 defines the symbol encoding for each of the preambles.
- Bits 4-27 of the sub-frame contain the 24 bit audio sample in 2's complement format with bit 27 as the most significant bit (MSB). For 16 bit mode, Bits 4-11 are all 0.
- Bit 28 is the validity flag. This is equal to V bit in the register.
- Bit 29 is a user data bit. This is always "0" in the AK4353.
- Bit 30 is a channel status bit. Frame 0 contains the first bit of the 192 bit word with the last bit in frame 191.
- Bit 31 is an even parity bit for bits 4-31 of the sub-frame.

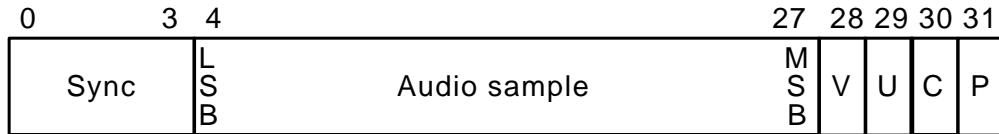

Figure 8. Sub-frame format

The block of data contains consecutive frames transmitted at a bit rate of 64 times the sample frequency, fs.

Preamble	Preceding state = 0	Preceding state = 1
B	11101000	00010111
M	11100010	00011101
W	11100100	00011011

Table 4. Sub-frame preamble encoding

Figure 9 shows the relation between input data to SDTI pin and audio data on sub-frame.

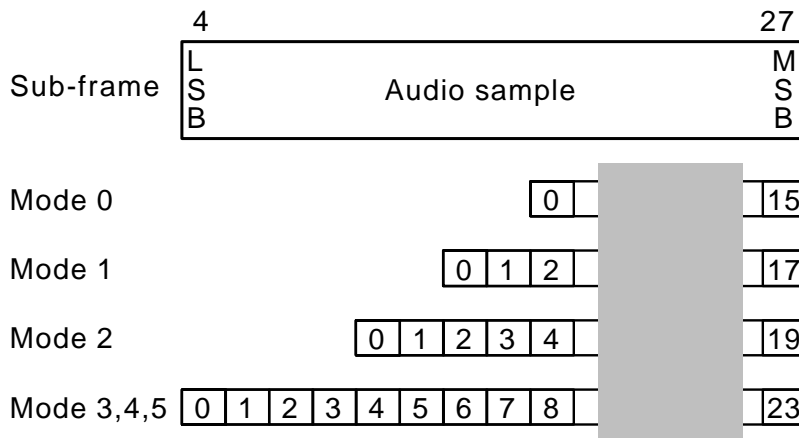

Figure 9. Relation between input data to SDTI pin and audio data on sub-frame

■ De-emphasis filter

A digital de-emphasis filter is available for 32, 44.1 or 48kHz sampling speed ($t_c=50/15\mu s$). It is enabled or disabled with the control register data of DEM1-0 and DFS1-0. The de-emphasis filter is disabled at half/double sampling mode.

DEM1	DEM0	De-emphasis
0	0	44.1kHz
0	1	OFF
1	0	48kHz
1	1	32kHz

default

Table 5. De-emphasis filter control with DEM1-0 (DFS1-0="00")

DFS1	DFS0	De-emphasis
0	0	See Table 5.
0	1	OFF
1	0	OFF
1	1	OFF

default

Table 6. De-emphasis filter control with DFS1-0

■ Zero detection

When the input data at both channels is continuously zeros for 8192 LRCK cycles, DZF pin goes to “H”. DZF pin immediately goes to “L” if input data is not zero after going DZF “H”. If RSTN bit becomes “0”, DZF pin goes to “H”. DZF pin goes to “L” at $4\sim 5/f_s$ after RSTN bit returns to “1”.

■ Soft mute operation

Soft mute operation is performed at digital domain. When the serial control register data of SMUTE goes “1”, the output signal is attenuated by $-\infty$ during 1024 LRCK cycles. When SMUTE is returned to “0”, the mute is cancelled and the output attenuation gradually changes to 0dB during 1024 LRCK cycles. If the soft mute is cancelled within 1024 LRCK cycles after starting the operation, the attenuation is discontinued and returned to 0dB. The soft mute is effective for changing the signal source without stopping the signal transmission.

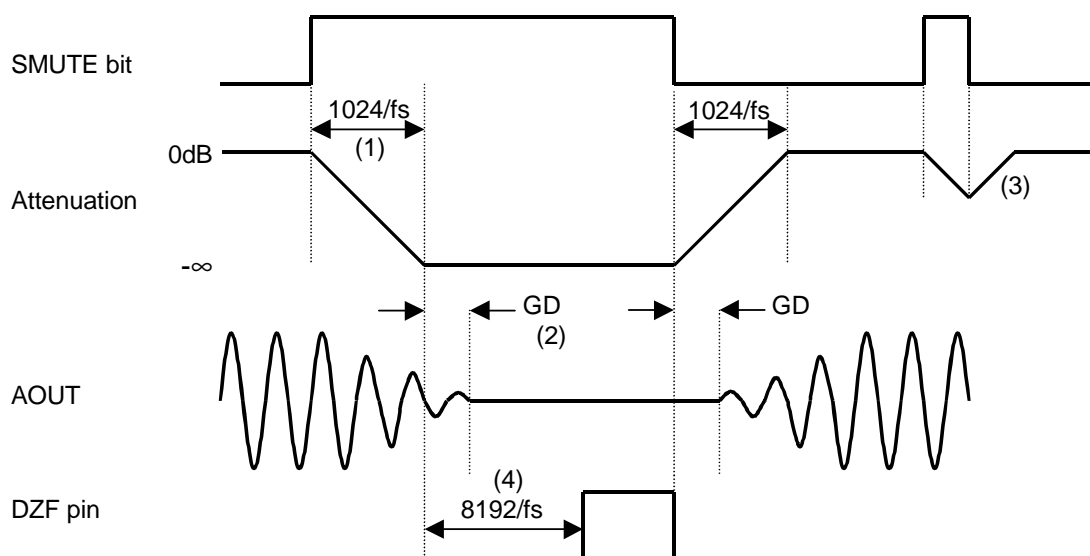

Notes:

- (1) The output signal is attenuated by $-\infty$ during 1024 LRCK cycles ($1024/f_s$).
- (2) Analog output corresponding to digital input have the group delay (GD).
- (3) If the soft mute is cancelled within 1024 LRCK cycles, the attenuation is discontinued and returned to 0dB.
- (4) When the input data at both channels are continuously zeros for 8192 LRCK cycles, DZF pin goes to “H”. DZF pin immediately goes to “L” if input data are not zero after going DZF “H”.

Figure 10. Soft mute and zero detection

■ Power-down

The DAC is placed in the power-down mode by bringing PDN pin “L” and the digital filter is also reset at the same time. The internal register values are initialized by PDN “L”. This reset should always be done after power-up. Because some click noise occurs at the edge of PDN, the analog output should be muted externally if the click noise influences system application.

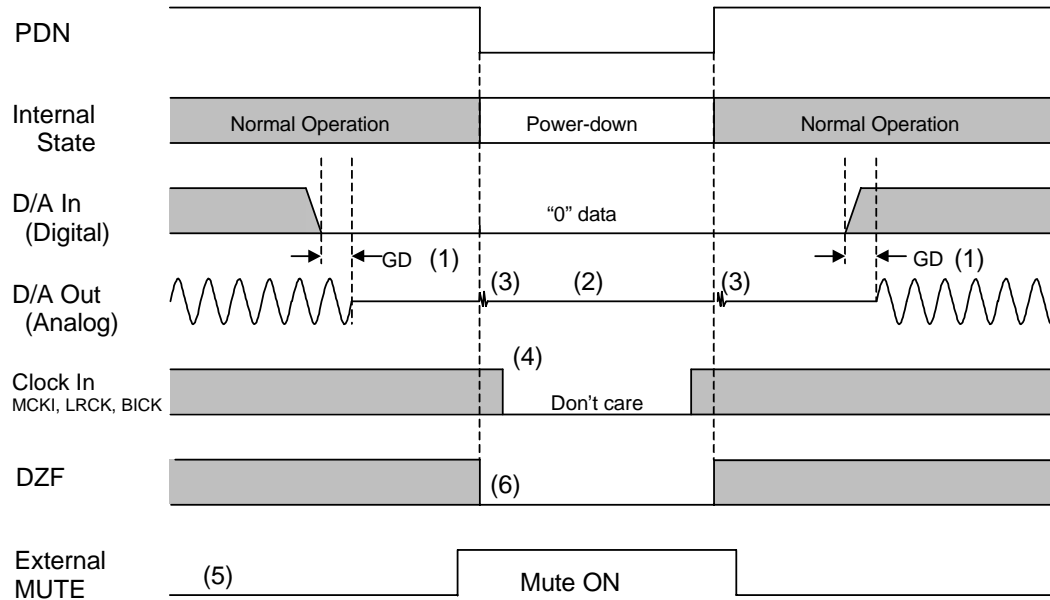

Notes:

- (1) The analog output corresponding to digital input has the group delay (GD).
- (2) Analog outputs are floating (Hi-Z) at the power-down mode.
- (3) Click noise occurs at the edge of PDN signal. This noise is output even if "0" data is input.
- (4) The external clocks (MCKI, BICK and LRCK) can be stopped in the power-down mode (PDN = "L").
- (5) Please mute the analog output externally if the click noise (3) influences system application.
The timing example is shown in this figure.
- (6) DZF pin is "L" in the power-down mode (PDN = "L").

Figure 11. Power-down/up sequence example

■ Reset function

When RSTN = "0", the DAC is powered down but the internal register values are not initialized. The analog outputs go to VCOM voltage and DZF pin goes to "H". Figure 12 shows the sequence of reset by RSTN bit.

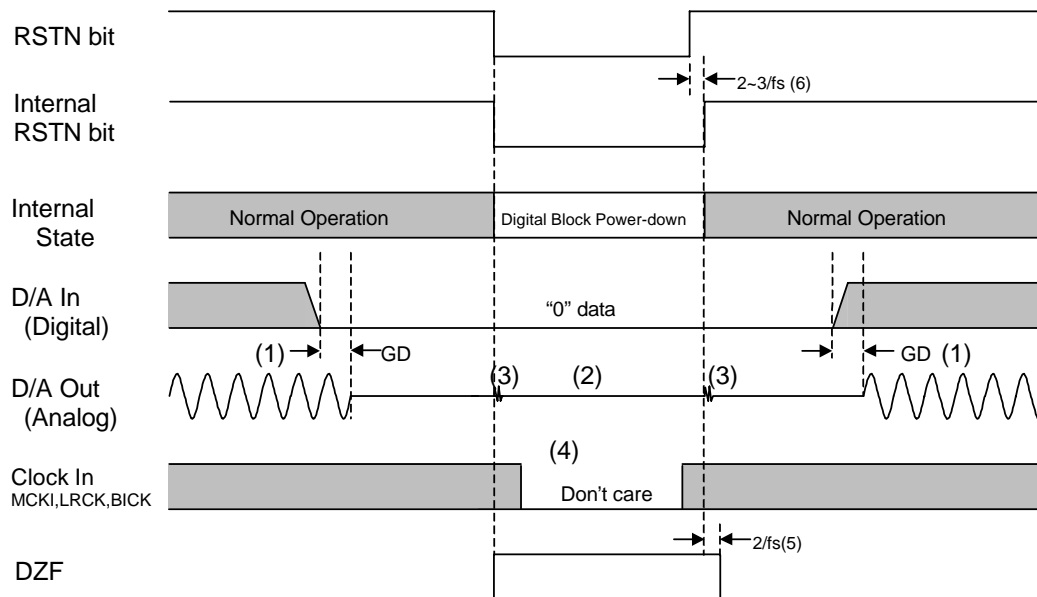

Notes:

- (1) The analog output corresponding to digital input has the group delay (GD).
- (2) Analog outputs go to VCOM voltage.
- (3) Click noise occurs at the edges ("↑ ↓") of the internal timing of RSTN bit. This noise is output even if "0" data is input.
- (4) The external clocks (MCKI, BICK and LRCK) can be stopped in the reset mode (RSTN = "L").
- (5) DZF pin goes to "H" when the RSTN bit becomes "0", and goes to "L" at $4\sim 5/f_s$ after RSTN bit becomes "1".
- (6) There is a delay, $2\sim 3/f_s$ from RSTN bit "1" to the internal RSTN "1".

Figure 12. Reset sequence example

Serial Control Interface

The AK4353 can control its functions via registers. Internal registers may be written by 2 types of control mode. The chip address is determined by the state of the CAD0 and CAD1 inputs. PDN = "L" initializes the registers to their default values. Writing "0" to the RSTN bit can initialize the internal timing circuit. But in this case, the register data is not be initialized.

(1) 3-wire Serial Control Mode (I2C = "L")

Internal registers may be written to the 3 wire μ P interface pins (CSN,CCLK and CDTI). The data on this interface consists of Chip address (2bits, CAD0/1), Read/Write (1bit, Fixed to "1"; Write only), Register address (MSB first, 5bits) and Control data (MSB first, 8bits). Address and data is clocked in on the rising edge of CCLK and data is clocked out on the falling edge. For write operations, data is latched after a low-to-high transition of CSN. The clock speed of CCLK is 5MHz(max). The CSN and CCLK pins should be held to "H" except for access.

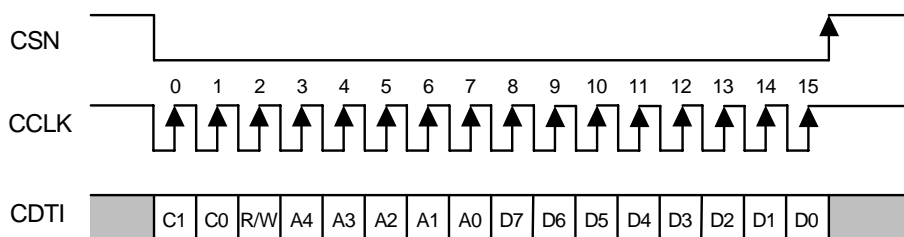

C1-C0: Chip Address (C1=CAD1, C0=CAD0)
 R/W: Read/Write (Fixed to "1" : Write only)
 A4-A0: Register Address
 D7-D0: Control Data

(2) I²C Bus Control Mode (I2C = "H")

Internal registers may be written to I²C Bus interface pins: SCL & SDA. The data on this interface consists of Chip address (2bits, CAD0/1), Read/Write (1bit, Fixed to "0"; Write only), Register address (MSB first, 5bits) and Control data (MSB first, 8bits). Address and data is clocked in on the rising edge of SCL and data is clocked out on the falling edge. Data can be written after a high-to-low transition of SDA when SCL is "H"(start condition), and is latched after a low-to-high transition of SDA when SCL is "H"(stop condition). The clock speed of SCL is 100kHz(max). The CSN pin should be connected to DVDD at I²C Bus control mode. The AK4353 does not have a register address auto increment capability.

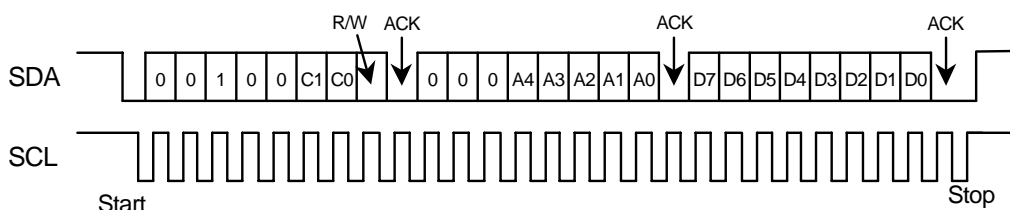

C1-C0: Chip Address (C1=CAD1, C0=CAD0)
 R/W: Read/Write (Fixed to "0" : Write only)
 A4-A0: Register Address
 D7-D0: Control Data
 ACK: Acknowledge

* When the AK4353 is in the power down mode (PDN = "L") or the MCLK is not provided, writing into the control register is inhibited.

■ Mapping of Program Registers

Addr	Register Name	D7	D6	D5	D4	D3	D2	D1	D0
00H	Control 1	0	0	0	0	DIF2	DIF1	DIF0	RSTN
01H	Control 2	0	0	DFS1	DFS0	CKS2	CKS1	CKS0	RSTN
02H	Control 3	PL3	PL2	PL1	PL0	DEM1	DEM0	ATC	SMUTE
03H	Lch ATT	ATT7	ATT6	ATT5	ATT4	ATT3	ATT2	ATT1	ATT0
04H	Rch ATT	ATT7	ATT6	ATT5	ATT4	ATT3	ATT2	ATT1	ATT0
05H	TX	0	0	0	0	0	0	V	TXE
06H	Channel Status 1	0	CS29	CS28	CS25	CS24	CS3	CS2	CS1
07H	Channel Status 2	CS15	CS14	CS13	CS12	CS11	CS10	CS9	CS8

Note: For addresses from 08H to 1FH, data should not be written.

When PDN goes to “L”, the registers are initialized to their default values.

When RSTN bit goes to “0”, the internal timing is reset, DZF pin goes to “H” and registers are not initialized to their default values.

■ Register Definitions

Addr	Register Name	D7	D6	D5	D4	D3	D2	D1	D0
00H	Control 1	0	0	0	0	DIF2	DIF1	DIF0	RSTN
	Default	0	0	0	0	1	0	1	1

RSTN: Internal timing reset

0: Reset. DZF pin goes to “H” and registers are not initialized.

1: Normal operation

When the states of DIF2-0,CKS2-0 or DFS1-0 changes, the AK4353 should be reset by PDN pin or RSTN bit. Some click noise may occur at that timing.

DIF2-0: Audio data interface modes (See Table 3.)

Initial: “101”, Mode 5

Addr	Register Name	D7	D6	D5	D4	D3	D2	D1	D0
01H	Control 2	0	0	DFS1	DFS0	CKS2	CKS1	CKS0	RSTN
	Default	0	0	0	0	0	0	0	1

RSTN: Internal timing reset

0: Reset. DZF pin goes to “H” and registers are not initialized.

1: Normal operation

When the states of DIF2-0,CKS2-0 or DFS1-0 changes, the AK4353 should be reset by PDN pin or RSTN bit. Some click noise may occur at that timing.

CKS2-0: Clock select (See Table 1.)

Initial: “000”

DFS1-0: Half/Normal/Double sampling modes (See Table 1), De-emphasis response (See Table 6.)

Initial: “00”

Addr	Register Name	D7	D6	D5	D4	D3	D2	D1	D0
02H	Control 3	PL3	PL2	PL1	PL0	DEM1	DEM0	ATC	SMUTE
	Default	1	0	0	1	0	1	0	0

SMUTE: Soft Mute Enable

0: Normal operation

1: DAC outputs soft-muted

ATC: Attenuation Control

0: The attenuation data for each register is applied separately to left and right channels.

1: The attenuation data loaded in addr=03H is used for both left and right channels.

DEM1-0: De-emphases response (See Table 5.6.)

Initial: "01", OFF

PL3-0: Mixing mode

PL3	PL2	PL1	PL0	Lch Output	Rch Output	Note
0	0	0	0	MUTE	MUTE	MUTE
0	0	0	1	MUTE	R	
0	0	1	0	MUTE	L	
0	0	1	1	MUTE	(L+R)/2	
0	1	0	0	R	MUTE	
0	1	0	1	R	R	
0	1	1	0	R	L	REVERSE
0	1	1	1	R	(L+R)/2	
1	0	0	0	L	MUTE	
1	0	0	1	L	R	STEREO
1	0	1	0	L	L	
1	0	1	1	L	(L+R)/2	
1	1	0	0	(L+R)/2	MUTE	
1	1	0	1	(L+R)/2	R	
1	1	1	0	(L+R)/2	L	
1	1	1	1	(L+R)/2	(L+R)/2	MONO

default

Table 7. Programmable Output Format

STEREO: Normal stereo output

REVERSE: L/R Reverse output

MONO: Monaural output

MUTE: Soft mute operation

Addr	Register Name	D7	D6	D5	D4	D3	D2	D1	D0
03H	Lch ATT	ATT7	ATT6	ATT5	ATT4	ATT3	ATT2	ATT1	ATT0
04H	Rch ATT	ATT7	ATT6	ATT5	ATT4	ATT3	ATT2	ATT1	ATT0
Default		1	1	1	1	1	1	1	1

Equation of attenuation level: $ATT = 20 \times \text{Log}_{10} (\text{Binary level} / 255)$ [dB]

FFH: 0dB

:

01H: -48.1dB

00H: Mute

The transition between ATT values is same as soft mute operation. When current value is ATT1 and new value is set as ATT2, ATT1 gradually becomes ATT2 with same operation as soft mute. If new value is set as ATT3 before reaching ATT2, ATT value gradually becomes ATT3 from the way of transition.

Cycle time of soft mute: $T_s = 1024/f_s$

When PDN pin goes to "L", the ATT values are set to 00H. The ATT values fade to FFH(0dB) during T_s after PDN pin returns to "H". When RSTN bit goes to "0", the ATT values are set to 00H. The ATT values fade to their current values after RSTN bit returns to "1". Digital attenuator is independent of soft mute function.

Addr	Register Name	D7	D6	D5	D4	D3	D2	D1	D0
05H	TX	0	0	0	0	0	0	V	TXE
	Default	0	0	0	0	0	0	0	1

TXE: TX output
 0: "L"
 1: Normal Operation

V: Validity Flag
 0: Valid
 1: Invalid

Addr	Register Name	D7	D6	D5	D4	D3	D2	D1	D0
06H	Channel Status 1	0	CS29	CS28	CS25	CS24	CS3	CS2	CS1
	Default	0	0	0	0	0	0	0	0

CS1 0: Audio
 1: Non-Audio

CS2 0: Copyright
 1: Non-Copyright

CS3 0: No Pre-emphasis
 1: 50/15 μ sec Pre-emphasis

CS24,25: Sampling Frequency
 00: 44.1kHz
 01: 48kHz
 10: Reserved
 11: 32kHz

CS28,29: Clock Accuracy
 00: Standard mode
 01: Variable pitch mode
 10: High accuracy mode
 11: Reserved

Addr	Register Name	D7	D6	D5	D4	D3	D2	D1	D0
07H	Channel Status 2	CS15	CS14	CS13	CS12	CS11	CS10	CS9	CS8
	Default	0	0	0	0	0	1	0	0

CS8-15: Category code (See the Standard of EIAJ.)
 00100000: Digital Audio Broadcast Reception in Japan (default)

■ Channel Status Explanation (from the Standard of EIAJ and IEC958)

	Bit 7	Bit 6	Bit 5	Bit 4	Bit 3	Bit 2	Bit 1	Bit 0
Byte 0	CS7	CS6	CS5	CS4	CS3	CS2	CS1	CS0
Byte 1	CS15	CS14	CS13	CS12	CS11	CS10	CS9	CS8
Byte 2	CS23	CS22	CS21	CS20	CS19	CS18	CS17	CS16
Byte 3	CS31	CS30	CS29	CS28	CS27	CS26	CS25	CS24

(Bold type: Programmable, Normal type: fixed in this device)

CS0 0: Consumer (fixed)

CS1 0: Audio
1: Non-audio

CS2 0: Copyright
1: Non-copyright

CS3-5 000: No pre-emphasis
100: 50/15μsec pre-emphasis (CS4-5: fixed to 00)

CS6-7: Mode
00: Mode 0 (fixed)

CS8-15: Category code (See the next page. For more detail information, please see the Standard of EIAJ.)

CS16-19: Source number
00: Not regulated (fixed)

CS20-23: Channel (fixed)
1000: Left
0100: Right

CS24-27: Sampling frequency
0000: 44.1kHz
0100: 48kHz
1100: 32kHz
others: Not regulated

CS28-29: Clock accuracy
00: Standard mode
01: Variable pitch mode
10: High accuracy mode
11: Not regulated

CS30- : Reserved (fixed to all 0)

Category code (bit 8-15)

bit15 (L bit): indicates generation of digital audio signal.

General

- 0: not regulated
- 1: recorded software issued for business

Optical disc machine (“100 xxxxL”), Broadcast reception (“001 xxxxL” and “011 1xxxL”)

- 0: recorded software issued for business
- 1: not regulated

“000 00000”: General (Digital audio reception without copyright information in Japan)

“100 xxxxL”: Optical disc machine

“100 0000L”: Compact disc adapted to IEC908

“100 1000L”: Optical disc not adapted to IEC908

“100 1001L”: Mini disc system

“100 1100L”: Digital video disc

“010 xxxxL” and “011 1xxxL”: Digital/digital converting machine and signal process machine

“010 0000L”: PCM encoder/decoder

“010 0100L”: Digital signal mixer

“010 1100L”: Sampling rate converter

“010 0010L”: Digital sound sampler

“110 xxxxL”: Magnetic tape and magnetic disc machine

“110 0000L”: Digital audio tape

“110 1000L”: Video tape recorder with digital voice

“110 0001L”: Digital compact cassette

“001 xxxxL”: Digital audio broadcast reception

“001 0000L”: in Japan (“001 00000”: default)

“001 1000L”: in Europe

“001 0011L”: in U.S.A

“001 0001L”: Software electronics delivery

“101 xxxxL”: Music instrument, microphone and source processing original signal

“101 0000L”: Synthesizer

“101 1000L”: Microphone

“011 00xxx”: A/D converter without copyright information

“011 0000x”: A/D converter

“011 01xxL”: A/D converter with copyright information

“011 0100L”: A/D converter

“000 1xxxL”: Solid memory machine

“000 0001L”: Experimental machine not used for business

“111 xxxxL”: Not regulated

“000 0xxxL”: Not regulated (except for “000 00000” and “000 0001L”)

SYSTEM DESIGN

Figure 13 shows the system connection diagram. An evaluation board is available which demonstrates application circuits, the optimum layout, power supply arrangements and measurement results.

Condition: AVDD=DVDD=5V(TTL mode), I2C mode, Chip Address="00"

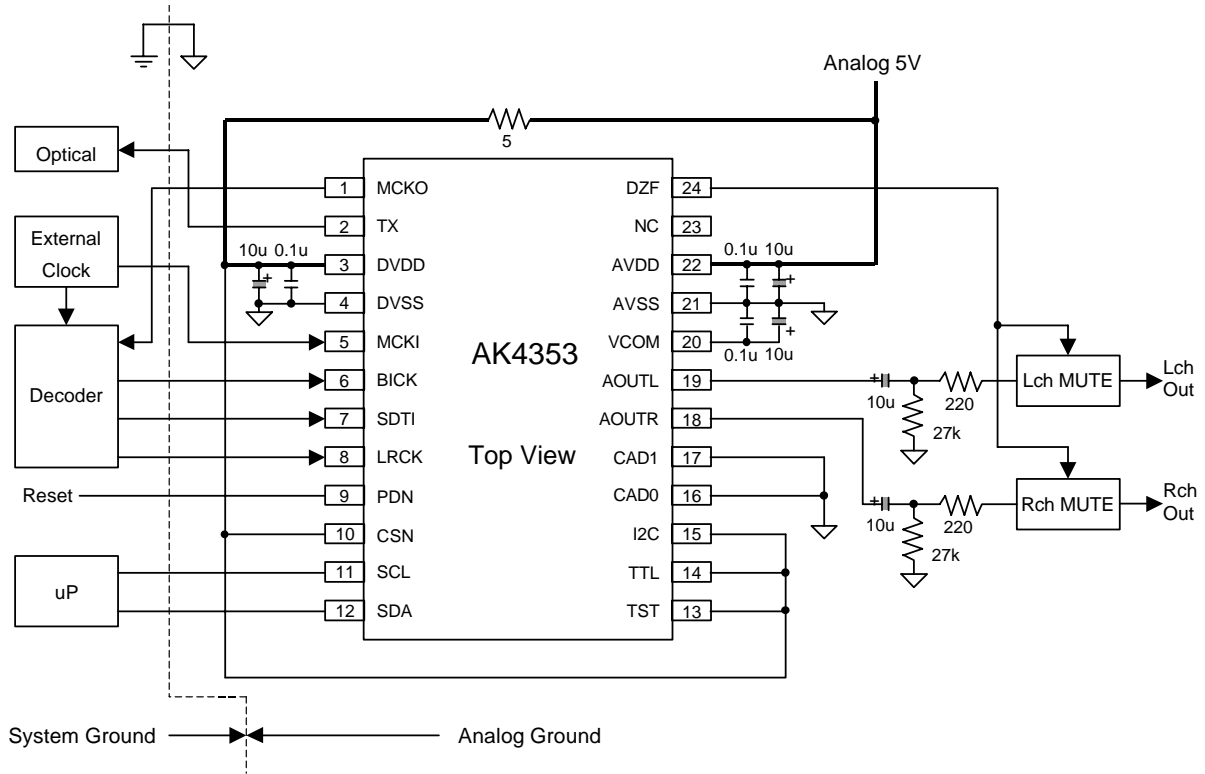

Figure 13. Typical Connection Diagram

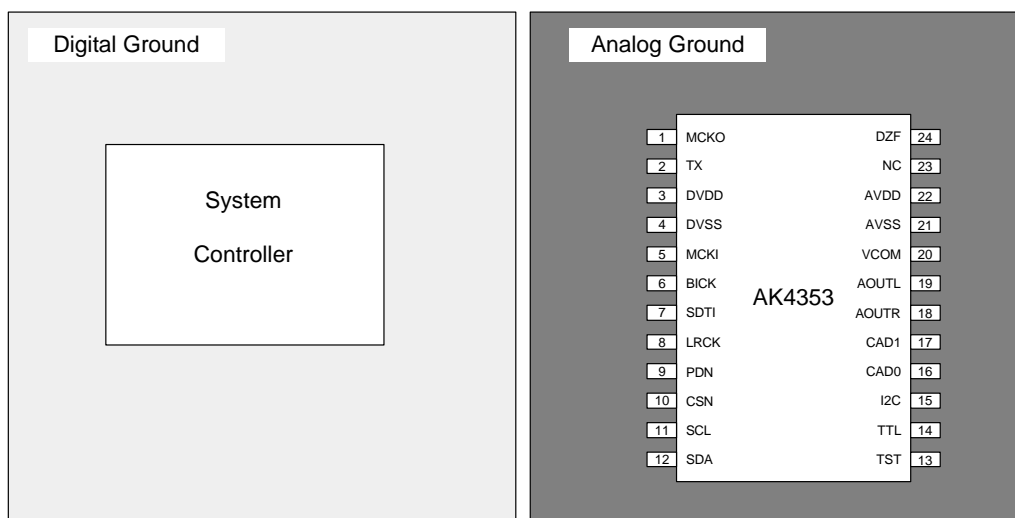

Figure 14. Ground Layout

Note: AVSS and DVSS must be connected to the same analog ground plane.

1. Grounding and Power Supply Decoupling

The AK4353 requires careful attention to power supply and grounding arrangements. AVDD and DVDD are usually supplied from analog supply in system. Alternatively if AVDD and DVDD are supplied separately, the power up sequence is not critical. **AVSS and DVSS of the AK4353 must be connected to analog ground plane.** System analog ground and digital ground should be connected together near to where the supplies are brought onto the printed circuit board. Decoupling capacitors should be near to the AK4353 as possible, with the small value ceramic capacitors being the nearest.

2. Voltage Reference Inputs

The differential voltage between AVDD and AVSS sets the analog output range. VCOM is AVDD/2 and normally connected to AVDD with a 0.1 μ F ceramic capacitor. An electrolytic capacitor 10 μ F parallel with a 0.1 μ F ceramic capacitor attached to VCOM pin eliminates the effects of high frequency noise. No load current may be drawn from these pins. All signals, especially clocks, should be kept away from the VCOM pin in order to avoid unwanted coupling into the AK4353.

3. Analog Outputs

The analog outputs are single-ended outputs and $0.6 \times (AVDD - AVSS)$ V_{pp} (typ) centered around the VCOM voltage. The internal switched-capacitor filter and continuous-time filter attenuate the noise generated by the delta-sigma modulator beyond the audio passband. The input data format is 2's complement. The output voltage is a positive full scale for 7FFFFFFF(@24bit) and a negative full scale for 800000H(@24bit). The ideal output is 0V for 000000H(@24bit).

PACKAGE

24pin VSOP (Unit: mm)

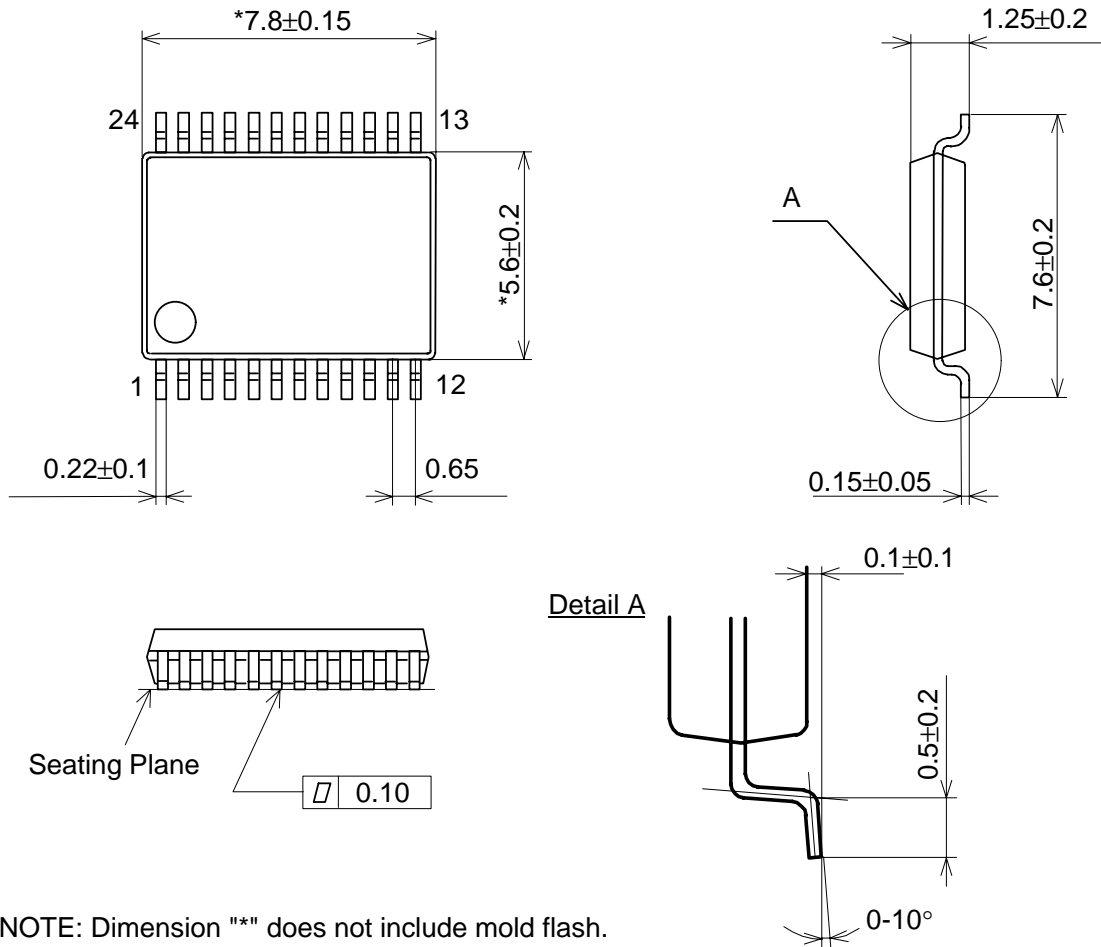

NOTE: Dimension "*" does not include mold flash.

■ Package & Lead frame material

Package molding compound:	Epoxy
Lead frame material:	Cu
Lead frame surface treatment:	Solder plate

MARKING

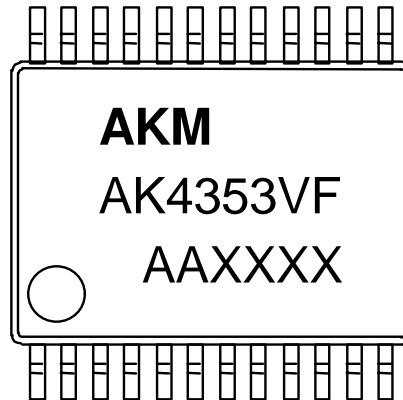

Contents of AAXXXX

AA: Lot#

XXXX: Date Code

IMPORTANT NOTICE

- These products and their specifications are subject to change without notice. Before considering any use or application, consult the Asahi Kasei Microsystems Co., Ltd. (AKM) sales office or authorized distributor concerning their current status.
- AKM assumes no liability for infringement of any patent, intellectual property, or other right in the application or use of any information contained herein.
- Any export of these products, or devices or systems containing them, may require an export license or other official approval under the law and regulations of the country of export pertaining to customs and tariffs, currency exchange, or strategic materials.
- AKM products are neither intended nor authorized for use as critical components in any safety, life support, or other hazard related device or system, and AKM assumes no responsibility relating to any such use, except with the express written consent of the Representative Director of AKM. As used here:
 - (a) A hazard related device or system is one designed or intended for life support or maintenance of safety or for applications in medicine, aerospace, nuclear energy, or other fields, in which its failure to function or perform may reasonably be expected to result in loss of life or in significant injury or damage to person or property.
 - (b) A critical component is one whose failure to function or perform may reasonably be expected to result, whether directly or indirectly, in the loss of the safety or effectiveness of the device or system containing it, and which must therefore meet very high standards of performance and reliability.
- It is the responsibility of the buyer or distributor of an AKM product who distributes, disposes of, or otherwise places the product with a third party to notify that party in advance of the above content and conditions, and the buyer or distributor agrees to assume any and all responsibility and liability for and hold AKM harmless from any and all claims arising from the use of said product in the absence of such notification.