

EVALUATION KIT
AVAILABLE

8-Channel PMICs for Digital Camera Power Supplies

General Description

The MAX8610–MAX8613/MAX8611V are highly efficient complete power-supply solutions for digital still cameras (DSCs) and digital video cameras (DVCs). Seven internal-MOSFET DC-DC converters provide up to 95% efficiency and generate all critical power supplies in DSC systems. They also feature True Shutdown™, as well as internal compensation to minimize external component count. One additional converter operates with an external MOSFET for optimum design flexibility. In all, eight converter channels include:

- Synchronous-rectified step-up with True Shutdown.
- Two synchronous-rectified step-down (MAX8611/MAX8613/MAX8611V) or step-up (MAX8610/MAX8612) converters power DSC system, I/O, and AFE blocks.
- Low- V_{OUT} (down to 1V), synchronous-rectified step-down to power a DSP core.
- High-output-voltage step-up for CCD bias.
- Transformerless inverter for negative CCD bias.
- High-output-voltage step-up for white LEDs, OLED display, or other output.
- Auxiliary DC-DC boost (MAX8611/MAX8610/MAX8611V) or inverting (MAX8612/MAX8613) controller.

The MAX8611/MAX8613/MAX8611V operate in 1-cell lithium-ion (Li+) and dual-battery (Li+ and 2 AA) designs. The MAX8610/MAX8612 operate in 2 AA designs.

Applications

DSCs and DVCs

PDAs and MP3 Players

True Shutdown is a trademark of Maxim Integrated Products, Inc.

Typical Operating Circuit

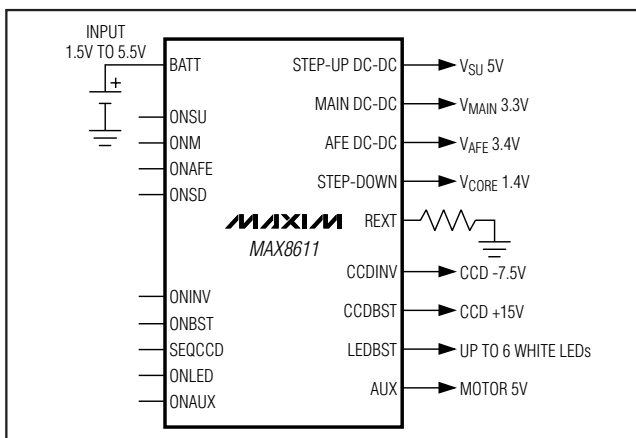

Features

- ◆ 95% Efficient Synchronous-Rectified DC-DCs
- ◆ 90% Efficient Boost-Buck Operation
- ◆ 85% Efficient DC-DCs for CCD, LCD, WLED, and/or OLED
- ◆ Auxiliary Power for Motors (MAX8610/MAX8611/MAX8611V)
- ◆ Internal Compensation
- ◆ True Shutdown Step-Up Converters
- ◆ Overload Protection
- ◆ Soft-Start for Controlled Startup Current
- ◆ Low-Dropout (100% Duty Cycle) Step-Downs
- ◆ Regulated Current for Up to 6 White LEDs
- ◆ Open-LED Overvoltage Protection
- ◆ Transformerless Inverting Converter for CCD
- ◆ Adjustable 1MHz to 2MHz Switching Frequency
- ◆ 3% Frequency Accuracy
- ◆ 1 μ A Shutdown Supply Current
- ◆ CCD Voltage Sequencing
- ◆ Voltage Tracking for Core and Logic (MAX8611/MAX8613/MAX8611V)
- ◆ Compact 48-Pin, 6mm x 6mm Thin QFN Package

Ordering Information

PART	TEMP RANGE	PIN-PACKAGE	PKG CODE
MAX8610ETM+**	-40°C to +85°C	48 TQFN-EP* 6mm x 6mm	T4866-1
MAX8611ETM+	-40°C to +85°C	48 TQFN-EP* 6mm x 6mm	T4866-1
MAX8611VETM+**	-40°C to +85°C	48 TQFN-EP* 6mm x 6mm	T4866-1
MAX8612ETM+**	-40°C to +85°C	48 TQFN-EP* 6mm x 6mm	T4866-1
MAX8613ETM+**	-40°C to +85°C	48 TQFN-EP* 6mm x 6mm	T4866-1

*EP = Exposed paddle.

+Denotes lead-free package.

**Future product—contact factory for availability.

Selector Guide and Pin Configuration appear at end of data sheet.

8-Channel PMICs for Digital Camera Power Supplies

MAX8610-MAX8613/MAX8611V

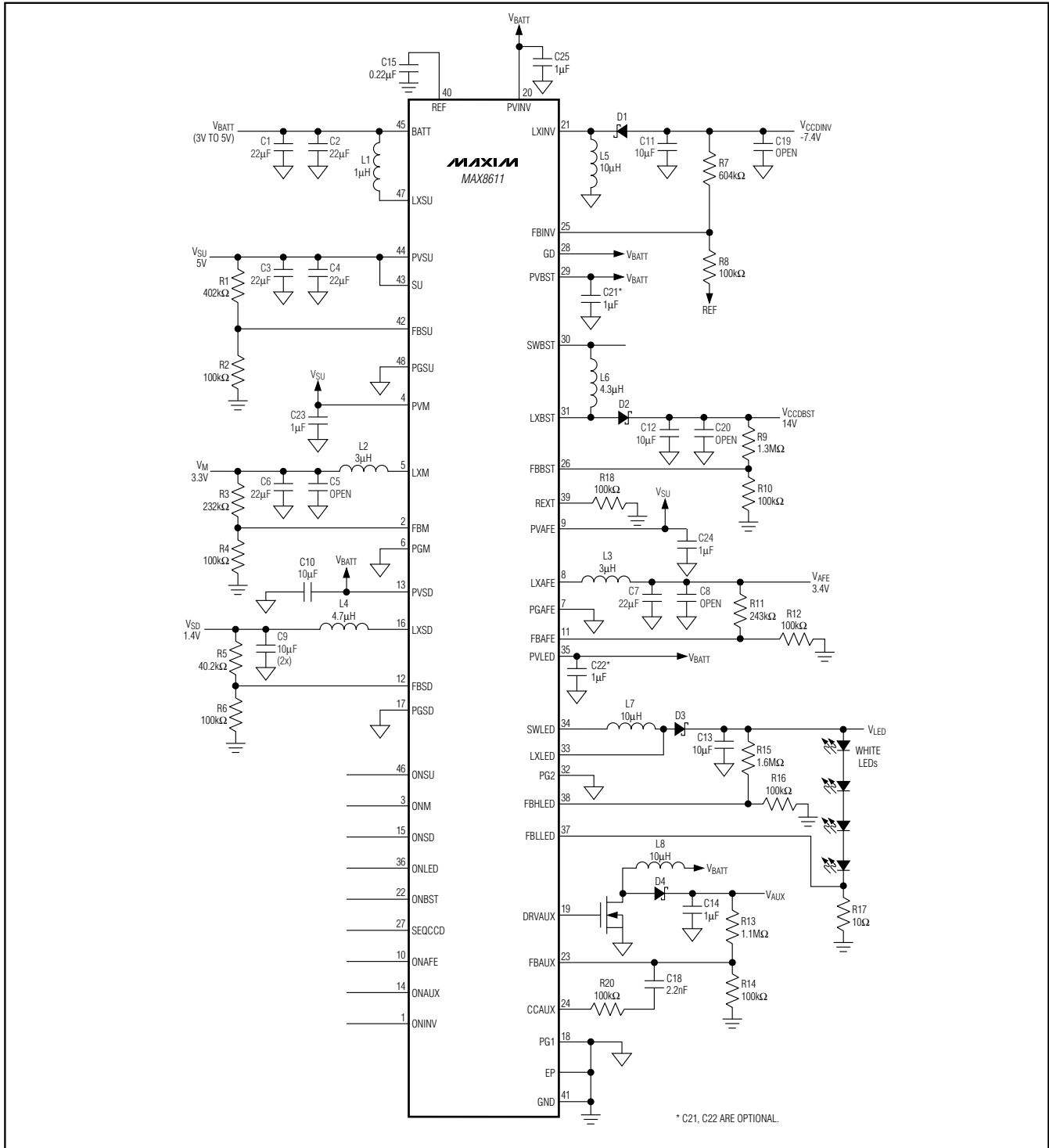

Figure 2. MAX8611 (Li+ or Combination Li+/2 AA Input) Typical Application Circuit. The MAIN (M) and AFE outputs operate as step-down converters and are powered from the step-up (SU) for efficient boost-buck operation.