

SPECIFICATIONS

GENERAL SPECIFICATIONS			OUTPUT SPECIFICATIONS		
Input voltage, continuous	Typical	0~75V	Output current	Ta=75°C, no airflow	5A
Input voltage, transient	Typical	100V	Output current	Ta=85°C, no airflow	4A
Operation case temperature	Typical	-40°C ~ 120°C	Common-mode Insertion Loss	50Ω circuit, 500 kHz (Typ)	43dB
Storage temperature	Typical	-55°C ~ 125°C	Differential-mode Insertion Loss	50Ω circuit, 500 kHz (Typ)	45dB
Size	(1.0" x 1.0"x 0.4")	25.4 x 25.4 x 10.2 mm			

ELECTRICAL CHARACTERISTICS CURVES

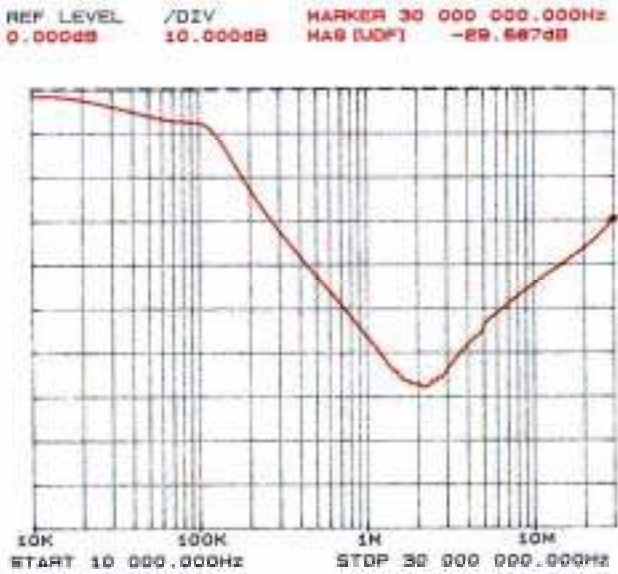

Figure 1: Typical common-mode insertion loss in a 50Ω circuit



Figure 2: Typical differential-mode insertion loss in a 50Ω circuit

Internal Schematics

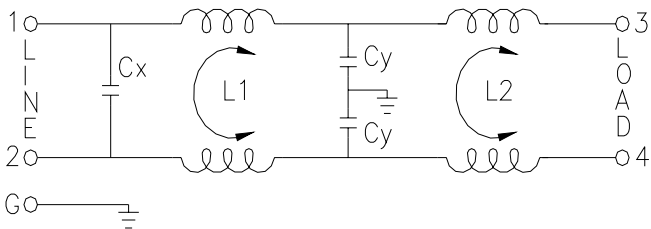

Figure 3: Internal schematics

THERMAL CONSIDERATIONS

Thermal management is an important part of the system design. To ensure proper, reliable operation, sufficient cooling of the power module is needed over the entire temperature range of the module. Convection cooling is usually the dominant mode of heat transfer.

Hence, the choice of equipment to characterize the thermal performance of the power module is a wind tunnel.

Thermal Testing Setup

Delta's filter modules are characterized in heated vertical wind tunnels that simulate the thermal environments encountered in most electronics equipment. This type of equipment commonly uses vertically mounted circuit cards in cabinet racks in which the power modules are mounted.

The following figure shows the wind tunnel characterization setup. The filter module is mounted on a test PWB and is vertically positioned within the wind tunnel. The space between the neighboring PWB and the top of the power module is 6.35mm (0.25").

Thermal Derating

Heat can be removed by increasing airflow over the module. Figure 4 shows maximum output is a function of ambient temperature and airflow rate. To enhance system reliability, the power module should always be operated below the maximum operating temperature. If the temperature exceeds the maximum module temperature, reliability of the unit may be affected.

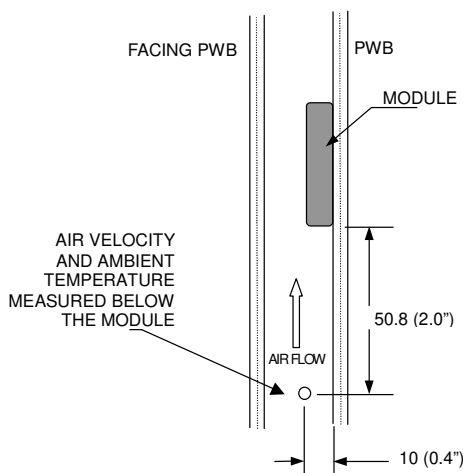

Note: Wind Tunnel Test Setup Figure Dimensions are in millimeters and (Inches)

Figure 4: Wind tunnel test setup figure dimensions are in millimeters and (inches).

THERMAL CURVES

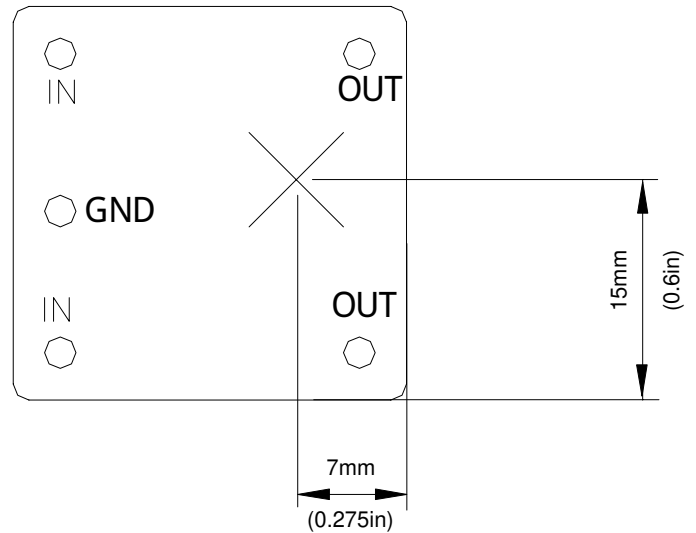

Figure 5: Temperature measurement location
The allowed maximum hot spot temperature is defined at 120°C

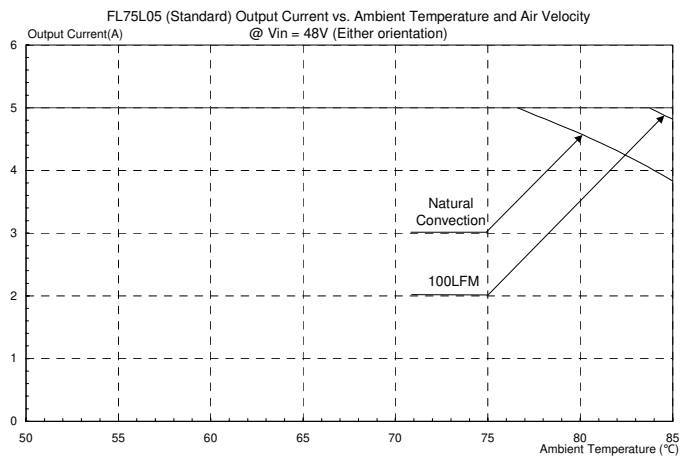
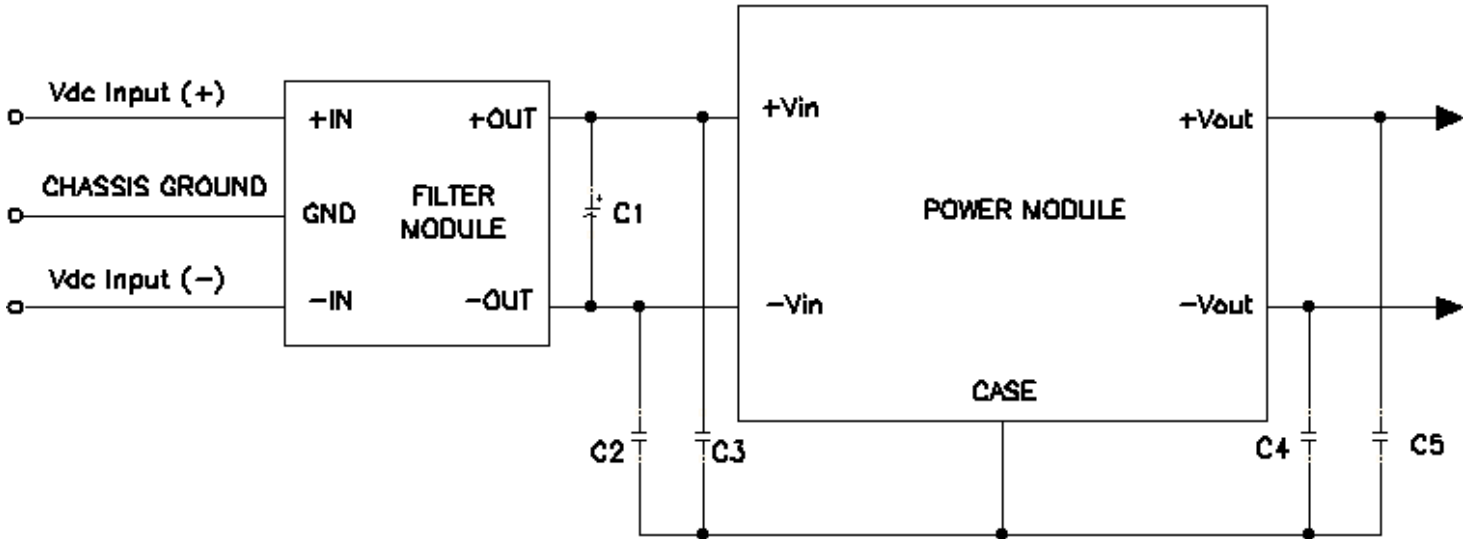

Figure 6: Output Current vs. Ambient Temperature and Air Velocity @ Vin = 48V (Either Orientation)

APPLICATION



Note: C2 through C5 can be $0.01\mu\text{F}$ to $0.1\mu\text{F}$. Select the voltage rating to meet input-to-output isolation requirements. C1 should be the recommended value indicated in the power module data sheet.

Figure 7. Recommended schematic when used as the input filter to a high-frequency dc-to-dc converter

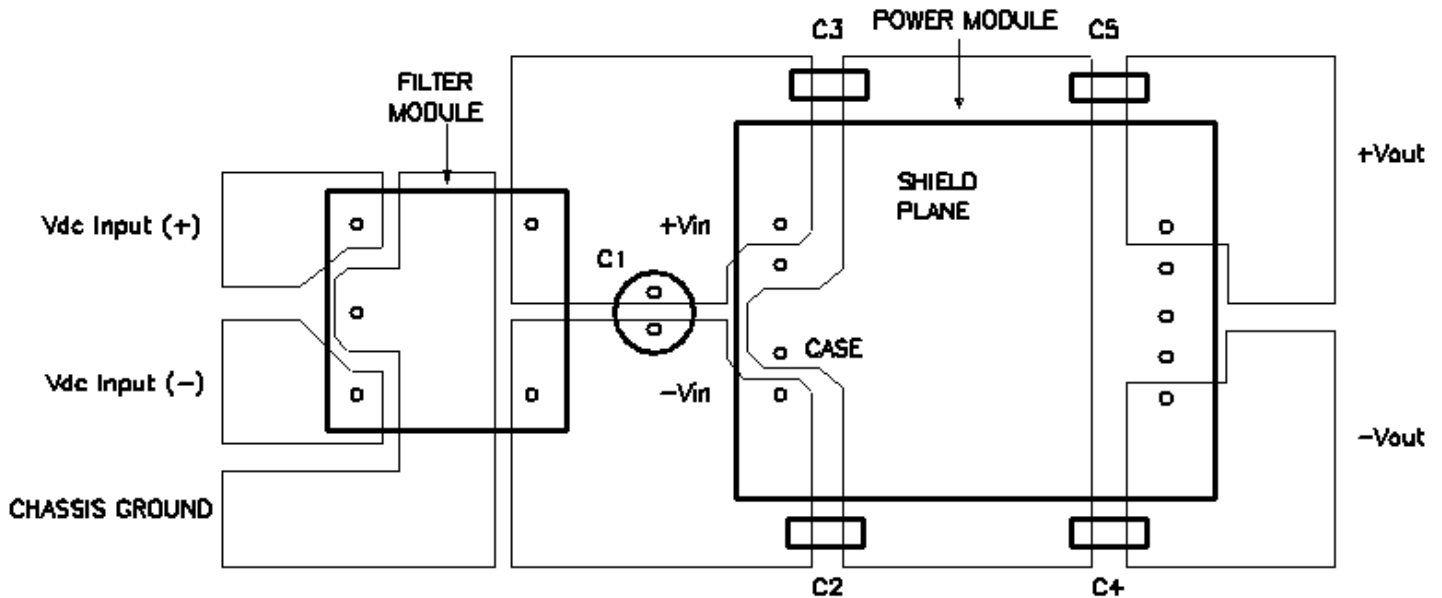

Note: Vdc input(+) and Vdc input(-) planes should overlay each other, as should the Vi(+) and Vi(-) planes, as should the Vout(+) and Vout(-) planes. Avoid routing signals or planes under the power module or the filter module. Ensure all connections are low impedance.

Figure 8. Recommended layout when used as the input filter to a high-frequency dc-to-dc converter

APPLICATION (Continued)

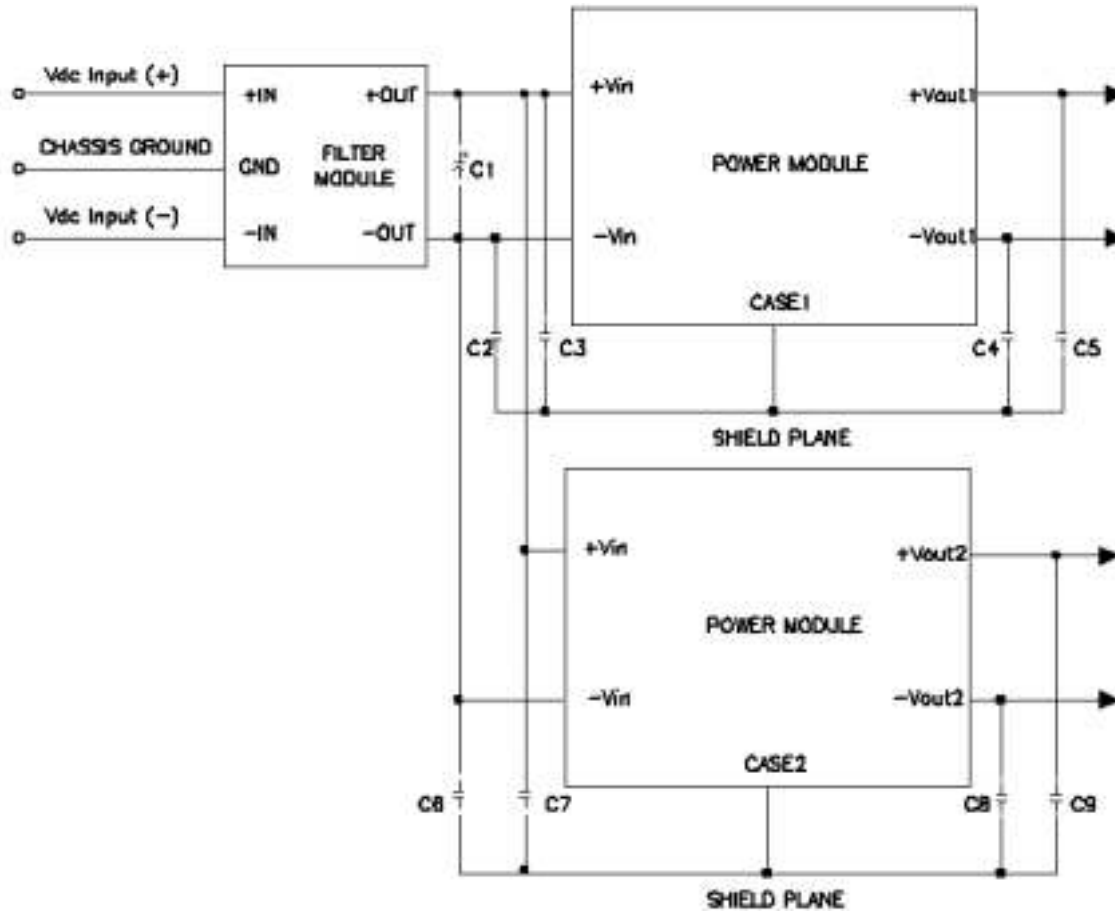

Note: : C2 through C5 and C6 through C9 can be $0.01\mu\text{ F}$ to $0.1\mu\text{ F}$. Select the voltage rating to meet input-to-output isolation requirements. C1 should be the recommended value indicated in the power module datasheet.

Figure 9. Recommended schematic of filter module with two power modules



Figure 10 shows the experimental result obtained by using this filter module, together with the recommended external components shown in Figures 5 and 6. The Q48SR3R335NR module is one of the Delphi series quarter brick 3.3V, 35A DCDC converters. Measured noise is greatly dependent on layout, grounding, cable orientation, and load characteristics and the variation is possible from various application conditions.

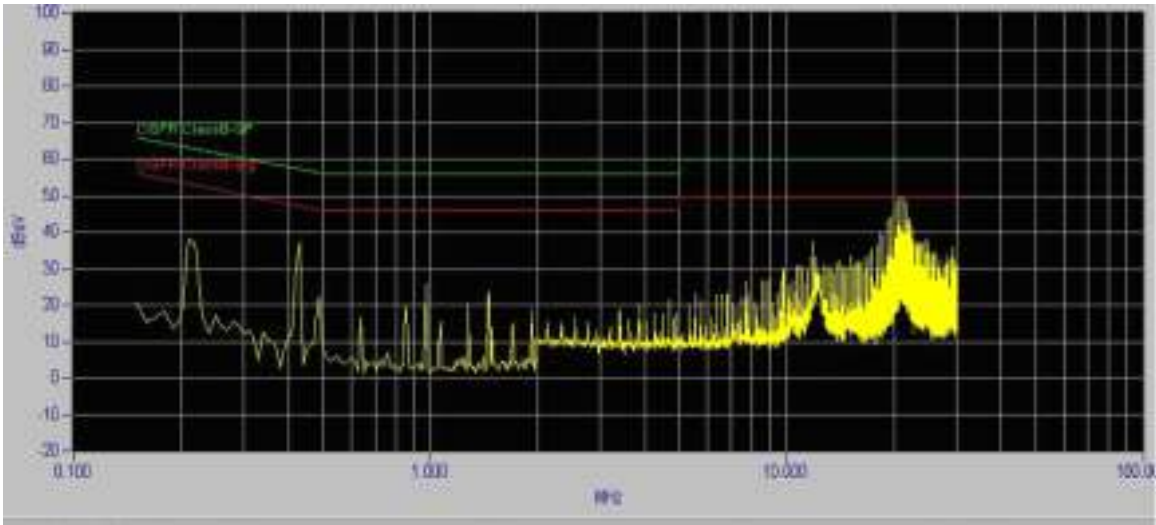
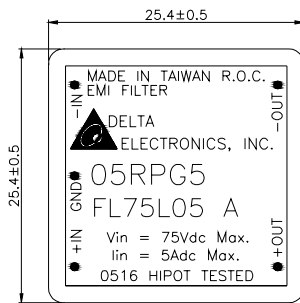

Figure 10. Q48SR3R335NR A conducted noise with FL75L05 input filter

MECHANICAL DRAWING

Top View



Side View

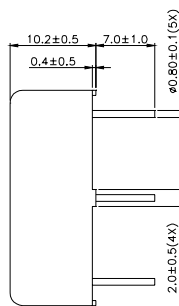

Bottom View

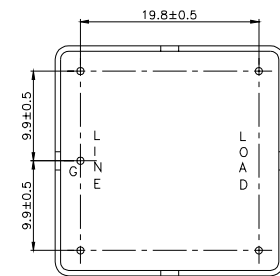

Dimensions are in millimeter and (inches).

Tolerances : x.xx ± 0.5 mm (0.02 in), x.xxx ± 0.25 mm (0.010 in)

RECOMMENDED HOLE PATTERN

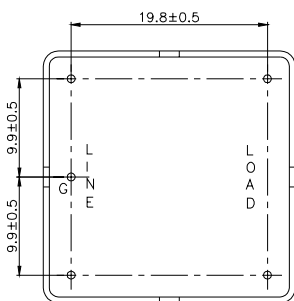

Dimensions are in millimeter and (inches).

Tolerances : x.xx ± 0.5 mm (0.02 in), x.xxx ± 0.25 mm (0.010 in)

PART NUMBERING SYSTEM

FL	75	L	05		A
Product Family	Input Voltage	Product Series	Output Current	Space	Option Code
FL- EMI Filter	75- 0 ~ 75V	L – Industry standard	05 - 5A		A - Standard Functions

MODEL LIST

Module Name	Input Voltage (max.)	Current Rating (max.)	Size (metric)	Size (English unit)
FL75L05 A	75V	5A	25.4 x 25.4 x 10.2 mm	1.0 in. x 1.0 in. x 0.4 in.
FL75L10 A	75V	10A	50.8 x 27.9 x 12.5 mm	2.0 in. x 1.1 in. x 0.5 in.
FL75L20 A	75V	20A	50.8 x 40.6 x 12.7 mm	2.0 in. x 1.6 in. x 0.5 in.

CONTACT: www.delta.com.tw/dcdc

USA:

Telephone:
East Coast: (888) 335 8201
West Coast: (888) 335 8208
Fax: (978) 656 3964
Email: DCDC@delta-corp.com

Europe:

Telephone: +41 31 998 53 11
Fax: +41 31 998 53 53
Email: DCDC@delta-es.tw

Asia & the rest of world:

Telephone: +886 3 4526107 ext 6220
Fax: +886 3 4513485
Email: DCDC@delta.com.tw

WARRANTY

Delta offers a two (2) year limited warranty. Complete warranty information is listed on our web site or is available upon request from Delta.

Information furnished by Delta is believed to be accurate and reliable. However, no responsibility is assumed by Delta for its use, nor for any infringements of patents or other rights of third parties, which may result from its use. No license is granted by implication or otherwise under any patent or patent rights of Delta. Delta reserves the right to revise these specifications at any time, without notice.