

GN 722.3

Steel / Stainless Steel

Square Cam Action Spring Latches

Lock-Out, with Mounting Flange, Parallel to the Latch Pin



JWWINCO
A Ganter Company

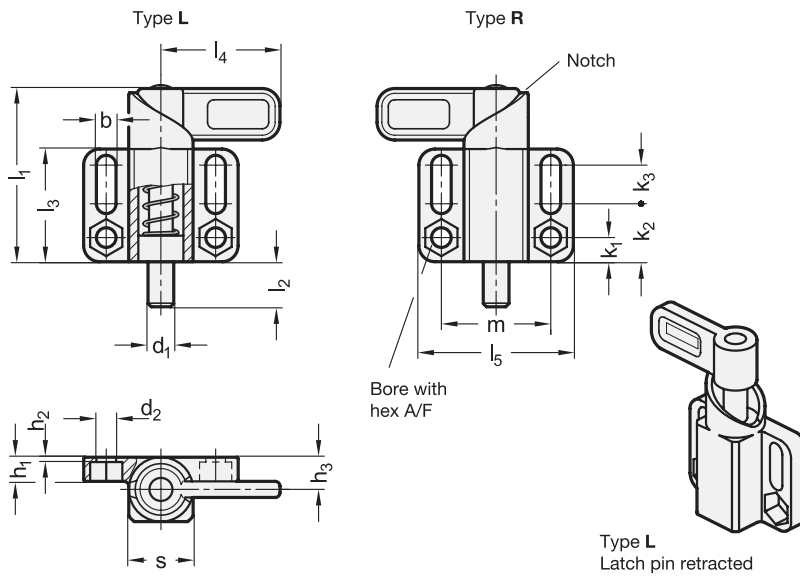

SS Stainless Steel

3 Type
L Left indexing cam
R Right indexing cam

Metric table

Dimensions in: millimeters - inches

d ₁ Pin -0.05 +0.1 Bore +0.3	s	b +0.3	d ₂ +0.2	h ₁	h ₂	h ₃	k ₁	k ₂	k ₃	l ₁ ≈	l ₂	l ₃	l ₄	l ₅	m	A/F	Spring load ≈	
																	Initial	End
8	20	6.1	6.1	7.5	1.5	10	7.5	18	12	54	14	35	37	48	34	10	15 N	50 N
0.31	0.79	0.24	0.24	0.30	0.06	0.39	0.30	0.71	0.47	2.13	0.55	1.38	1.46	1.89	1.34		3.37 lbf	11.24 lbf
10	20	6.1	6.1	7.5	1.5	10	7.5	18	12	54	14	35	37	48	34	10	15 N	50 N
0.39	0.79	0.24	0.24	0.30	0.06	0.39	0.30	0.71	0.47	2.13	0.55	1.38	1.46	1.89	1.34		3.37 lbf	11.24 lbf
12	20	6.1	6.1	7.5	1.5	10	7.5	18	12	54	14	35	37	48	34	10	15 N	50 N
0.47	0.79	0.24	0.24	0.30	0.06	0.39	0.30	0.71	0.47	2.13	0.55	1.38	1.46	1.89	1.34		3.37 lbf	11.24 lbf
14	20	6.1	6.1	7.5	1.5	10	7.5	18	12	54	14	35	37	48	34	10	15 N	50 N
0.55	0.79	0.24	0.24	0.30	0.06	0.39	0.30	0.71	0.47	2.13	0.55	1.38	1.46	1.89	1.34		3.37 lbf	11.24 lbf
16	30	10.1	10.1	15	5	15	14	34	10	83	20	54	55	80	55	17	30 N	110 N
0.63	1.18	0.40	0.40	0.59	0.20	0.59	0.55	1.34	0.39	3.27	0.79	2.13	2.17	3.15	2.17		6.74 lbf	24.73 lbf
20	30	10.1	10.1	15	5	15	14	34	10	83	20	54	55	80	55	17	30 N	110 N
0.79	1.18	0.40	0.40	0.59	0.20	0.59	0.55	1.34	0.39	3.27	0.79	2.13	2.17	3.15	2.17		6.74 lbf	24.73 lbf

Specification

- Body
 - Steel precision casting
 - Zinc plated, blue passivated finish **ZB**
 - Zinc plated and powder coated Black, RAL 9005, textured finish **SW**
 - Lever arm
 - Steel precision casting
 - Zinc plated, blue passivated finish
 - Latch pin
 - Steel
 - Zinc plated, blue passivated finish
 - Spring
 - Stainless steel AISI 316Ti
- Body / lever arm
 - Stainless steel precision casting AISI 316 **A4**
 - Latch pin
 - Stainless steel AISI 316
 - Spring
 - Stainless steel AISI 316Ti
- Load Rating Information → page 2103
- Stainless Steel Characteristics → page 2143
- RoHS compliant

Information

With GN 722.3 square cam action spring latches, the latch pin is withdrawn over the cam of the body by rotating the lever arm 180°. If the latch pin may need to be retracted periodically, the notch allows for safe positioning while the latch pin is held in the retracted position. The ZB and SW versions are designed for applications in steel construction, whereas the A4 stainless steel version is suitable for use in particularly aggressive environments.

The dimensional tolerances between latch pin and body are selected so that the functional reliability is guaranteed even with rough applications or in case of contamination.

For fastening, slotted or hexagonal mounting holes allow the use of DIN 912 socket cap screws and hex screws or nuts according to DIN 931 or DIN 934.

see also...

- List of Cam Action Indexing Plunger Types → page 1001
- Product Family Standard Parts for Profile Systems → page 2129
- Locating Bushings GN 412.2 / GN 412.4 → page 996
- Cam Action Indexing Plungers GN 612.2 / GN 612.9 → page 1010 / 1011

How to order	
1	Pin diameter d ₁
2	Square s
3	Type
4	Finish (Material)

GN 722.3-14-20-L-SW