

- PINS TO COMPLY WITH AMP SOLDERABILITY SPEC 109-11-3.
- MATES WITH PLUG P/N 172168-1.
- COORDINATE DIMENSION APPLIES FROM CENTER OF ACTUAL FEATURE.
- RECOMMENDED FOR EDGE MOUNTING.
- 0.00381 MIN MATTE TIN LEAD OVER 0.00127 MIN NICKEL ENTIRE LENGTH OF PIN.
- 0.00076 MIN GOLD PLATE IN THE LOCALIZED PLATE AREA, 0.00381 MIN MATTE TIN LEAD IN THE LOCALIZED PLATE AREA, BOTH OVER 0.00127 MIN NICKEL.
- 0.00381 MIN MATTE TIN OVER 0.00127 MIN NICKEL ENTIRE LENGTH OF PIN.
- 0.00076 MIN GOLD PLATE IN THE LOCALIZED GOLD PLATE AREA, 0.00381 MIN MATTE TIN IN THE LOCALIZED TIN PLATE AREA, BOTH OVER 0.00127 MIN NICKEL.

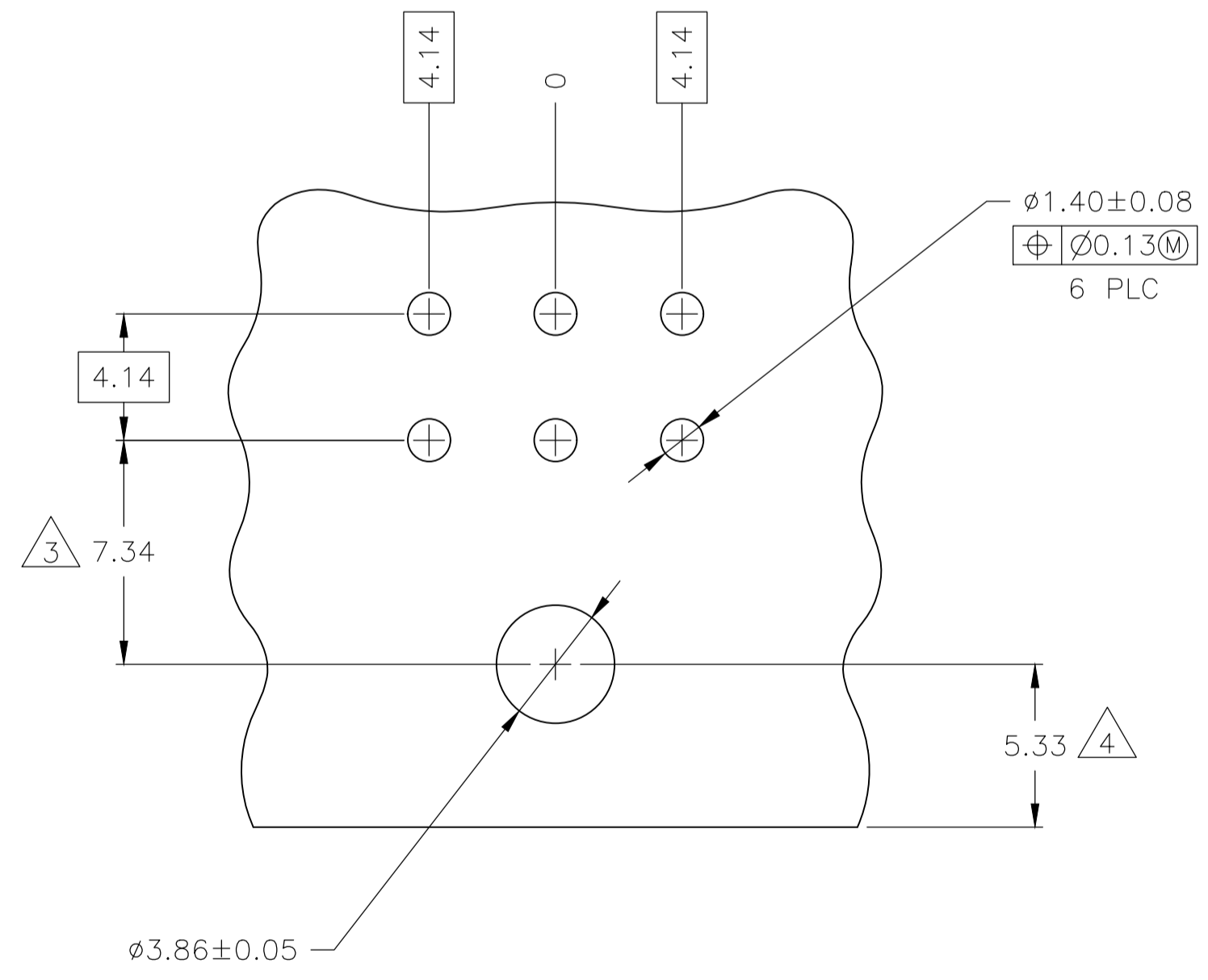

RECOMMENDED MOUNTING HOLE PATTERN FOR 1.57 THICK P.C. BOARD

3.68	.145	-	-
1.57	.062	14.00	.551
1.40	.055	12.70	.500
1.00	.039	9.80	.386
0.76	.030	7.34	.289
0.25	.010	6.86	.270
0.13	.005	6.10	.240
0.08	.003	5.99	.236
0.05	.002	5.33	.210
0.00381	0.000150	5.08	.200
0.00127	0.000050	4.14	.163
0.00076	0.000030	3.86	.152
MM	IN	MM	IN

CONVERSION TABLE

BRASS	8	NYLON, UL94V-0	WHITE	1-770969-1
BRASS	7	NYLON, UL94V-0	WHITE	1-770969-0
BRASS	6	NYLON, UL94V-0	WHITE	770969-2
OBSOLETE	5	NYLON, UL94V-0	WHITE	-770969-1-
MATERIAL	FINISH	MATERIAL	COLOR	PART NO.

THIS DRAWING IS A CONTROLLED DOCUMENT.

DIMENSIONS: mm	TOLERANCES UNLESS OTHERWISE SPECIFIED:	DBN S. CARPENTER 24JUL03 CHK C. JONES 24JUL03 APVD C. JONES 24JUL03 PRODUCT SPEC APPLICATION SPEC ANGLE: ± - WEIGHT: - CUSTOMER DRAWING	NAME: HEADER ASSEMBLY, RIGHT ANGLE, WITH SHORT PEG, 6 CIRCUIT, MINI UNIVERSAL MATE-N-LOK(TM) SIZE: A1 CAGE CODE: 00779 DRAWING NO: 770969 SCALE: 5:1 SHEET: 1 OF 1 REV: H1
----------------	--	--	--

STE TE Connectivity