



MICROCHIP

**RN131/RN171/RN1723 Evaluation Kits
User's Guide**

Note the following details of the code protection feature on Microchip devices:

- Microchip products meet the specification contained in their particular Microchip Data Sheet.
- Microchip believes that its family of products is one of the most secure families of its kind on the market today, when used in the intended manner and under normal conditions.
- There are dishonest and possibly illegal methods used to breach the code protection feature. All of these methods, to our knowledge, require using the Microchip products in a manner outside the operating specifications contained in Microchip's Data Sheets. Most likely, the person doing so is engaged in theft of intellectual property.
- Microchip is willing to work with the customer who is concerned about the integrity of their code.
- Neither Microchip nor any other semiconductor manufacturer can guarantee the security of their code. Code protection does not mean that we are guaranteeing the product as "unbreakable."

Code protection is constantly evolving. We at Microchip are committed to continuously improving the code protection features of our products. Attempts to break Microchip's code protection feature may be a violation of the Digital Millennium Copyright Act. If such acts allow unauthorized access to your software or other copyrighted work, you may have a right to sue for relief under that Act.

Information contained in this publication regarding device applications and the like is provided only for your convenience and may be superseded by updates. It is your responsibility to ensure that your application meets with your specifications. MICROCHIP MAKES NO REPRESENTATIONS OR WARRANTIES OF ANY KIND WHETHER EXPRESS OR IMPLIED, WRITTEN OR ORAL, STATUTORY OR OTHERWISE, RELATED TO THE INFORMATION, INCLUDING BUT NOT LIMITED TO ITS CONDITION, QUALITY, PERFORMANCE, MERCHANTABILITY OR FITNESS FOR PURPOSE. Microchip disclaims all liability arising from this information and its use. Use of Microchip devices in life support and/or safety applications is entirely at the buyer's risk, and the buyer agrees to defend, indemnify and hold harmless Microchip from any and all damages, claims, suits, or expenses resulting from such use. No licenses are conveyed, implicitly or otherwise, under any Microchip intellectual property rights.

Trademarks

The Microchip name and logo, the Microchip logo, dsPIC, FlashFlex, flexPWR, JukeBlox, KEELOQ, KEELOQ logo, Klear, LANCheck, MediaLB, MOST, MOST logo, MPLAB, OptoLyzer, PIC, PICSTART, PIC³² logo, RightTouch, SpyNIC, SST, SST Logo, SuperFlash and UNI/O are registered trademarks of Microchip Technology Incorporated in the U.S.A. and other countries.

The Embedded Control Solutions Company and mTouch are registered trademarks of Microchip Technology Incorporated in the U.S.A.

Analog-for-the-Digital Age, BodyCom, chipKIT, chipKIT logo, CodeGuard, dsPICDEM, dsPICDEM.net, ECAN, In-Circuit Serial Programming, ICSP, Inter-Chip Connectivity, KlearNet, KlearNet logo, MiWi, MPASM, MPF, MPLAB Certified logo, MPLIB, MPLINK, MultiTRAK, NetDetach, Omniscient Code Generation, PICDEM, PICDEM.net, PICkit, PICtail, RightTouch logo, REAL ICE, SQI, Serial Quad I/O, Total Endurance, TSHARC, USBCheck, VariSense, ViewSpan, WiperLock, Wireless DNA, and ZENA are trademarks of Microchip Technology Incorporated in the U.S.A. and other countries.

SQTP is a service mark of Microchip Technology Incorporated in the U.S.A.

Silicon Storage Technology is a registered trademark of Microchip Technology Inc. in other countries.

GestIC is a registered trademarks of Microchip Technology Germany II GmbH & Co. KG, a subsidiary of Microchip Technology Inc., in other countries.

All other trademarks mentioned herein are property of their respective companies.

© 2013-2015, Microchip Technology Incorporated, Printed in the U.S.A., All Rights Reserved.

ISBN: 978-1-63277-471-2

**QUALITY MANAGEMENT SYSTEM
CERTIFIED BY DNV
= ISO/ TS 16949 =**

Microchip received ISO/TS-16949:2009 certification for its worldwide headquarters, design and wafer fabrication facilities in Chandler and Tempe, Arizona; Gresham, Oregon and design centers in California and India. The Company's quality system processes and procedures are for its PIC[®] MCUs and dsPIC[®] DSCs, KEELOQ[®] code hopping devices, Serial EEPROMs, microperipherals, nonvolatile memory and analog products. In addition, Microchip's quality system for the design and manufacture of development systems is ISO 9001:2000 certified.

Objects of Declaration: RN131 Evaluation Kit, RN171 Evaluation Kit, RN1723 Evaluation Kit

EU Declaration of Conformity

Manufacturer: Microchip Technology Inc.
2355 W. Chandler Blvd.
Chandler, Arizona, 85224-6199
USA

This declaration of conformity is issued by the manufacturer.

The development/evaluation tool is designed to be used for research and development in a laboratory environment. This development/evaluation tool is not a Finished Appliance, nor is it intended for incorporation into Finished Appliances that are made commercially available as single functional units to end users under EU EMC Directive 2004/108/EC and as supported by the European Commission's Guide for the EMC Directive 2004/108/EC (8th February 2010).

This development/evaluation tool complies with EU RoHS2 Directive 2011/65/EU.

This development/evaluation tool, when incorporating wireless and radio-telecom functionality, is in compliance with the essential requirement and other relevant provisions of the R&TTE Directive 1999/5/EC and the FCC rules as stated in the declaration of conformity provided in the module datasheet and the module product page available at www.microchip.com.

For information regarding the exclusive, limited warranties applicable to Microchip products, please see Microchip's standard terms and conditions of sale, which are printed on our sales documentation and available at www.microchip.com.

Signed for and on behalf of Microchip Technology Inc. at Chandler, Arizona, USA

Derek Carlson
VP Development Tools

12-Sep-14
Date

RN131/171/1723 Evaluation Kits User's Guide

NOTES:



RN131/RN171/RN1723 EVALUATION KITS USER'S GUIDE

Table of Contents

Preface	7
Chapter 1. Overview	
1.1 RN Evaluation Kit Contents and Part Numbers	13
1.2 Example Code and Related Information	13
1.3 RN Evaluation Kit Hardware	14
1.4 RN Evaluation Board Features	15
1.5 RN Evaluation Board Components	16
Chapter 2. Getting Started	
2.1 Prerequisites	21
2.2 Hardware Configuration	22
2.3 Module Configuration	23
Chapter 3. Application Design Concerns	
3.1 Sensor Interfaces	27
3.2 Push Button Functions	27
Appendix A. Schematics, Bill of Materials, and Dimensions	
A.1 RN131 Evaluation Board	29
A.2 RN171 Evaluation Board and RN1723 Evaluation Board	33
A.3 Bill of Materials	37
A.4 Physical Dimensions	39
Worldwide Sales and Service	40

NOTES:

Preface

NOTICE TO CUSTOMERS

All documentation becomes dated, and this manual is no exception. Microchip tools and documentation are constantly evolving to meet customer needs, so some actual dialogs and/or tool descriptions may differ from those in this document. Please refer to our web site (www.microchip.com) to obtain the latest documentation available.

Documents are identified with a “DS” number. This number is located on the bottom of each page, in front of the page number. The numbering convention for the DS number is “DSXXXXXXXXA”, where “XXXXXXXX” is the document number and “A” is the revision level of the document.

For the most up-to-date information on development tools, see the MPLAB® X IDE online help. Select the Help menu, and then Topics to open a list of available online help files.

INTRODUCTION

This preface contains information that will be useful to know before using the RN131/RN171/RN1723 Evaluation Kits User's Guide. Topics discussed include:

- [Document Layout](#)
- [Conventions Used in this Guide](#)
- [Recommended Reading](#)
- [Recommended Reading](#)
- [The Microchip Web Site](#)
- [Development Systems Customer Change Notification Service](#)
- [Customer Support](#)
- [Document Revision History](#)

DOCUMENT LAYOUT

This document describes how to use the RN131 Evaluation Kit, the RN171 Evaluation Kit, and the RN1723 Evaluation Kit. The manual layout is as follows:

- **Chapter 1. “Overview”** – This chapter describes the evaluation kits that are used for demonstrating the capabilities of the RN131, RN171, and RN1723 modules. The RN evaluation boards in each kit have the flexibility to connect directly to a PC or laptop through a standard USB interface or to an embedded controller through the serial UART interface.
- **Chapter 2. “Getting Started”** – This chapter describes using an RN evaluation kit as an independent development board to add Wi-Fi® connectivity to embedded systems. Certain hardware and software prerequisites are essential to support the development of demonstration applications, which are discussed in this chapter.
- **Chapter 3. “Application Design Concerns”** – This chapter provides design concerns related to powering an RN evaluation board, including sensor interface settings, push button functions, and restoring factory settings.
- **Appendix A. “Schematics, Bill of Materials, and Dimensions”** – This appendix provides the schematics, Bill of Materials (BOM), and physical dimensions for the RN evaluation boards.

RN131/RN171/RN1723 Evaluation Kits User's Guide

CONVENTIONS USED IN THIS GUIDE

This manual uses the following documentation conventions:

DOCUMENTATION CONVENTIONS

Description	Represents	Examples
Italic characters	Referenced books	<i>MPLAB[®] IDE User's Guide</i>
	Emphasized text	...is the <i>only</i> compiler...
Initial caps	A window	the Output window
	A dialog	the Settings dialog
	A menu selection	select Enable Programmer
Quotes	A field name in a window or dialog	"Save project before build"
Underlined, italic text with right angle bracket	A menu path	<u><i>File > Save</i></u>
Bold characters	A dialog button	Click OK
	A tab	Click the Power tab
Text in angle brackets < >	A key on the keyboard	Press <Enter>, <F1>
Plain Courier New	Sample source code	#define START
	Filenames	autoexec.bat
	File paths	c:\mcc18\h
	Keywords	_asm, _endasm, static
	Command-line options	-Opa+, -Opa-
	Bit values	0, 1
	Constants	0xFF, 'A'
<i>Italic Courier New</i>	A variable argument	<i>file.o</i> , where <i>file</i> can be any valid filename
Square brackets []	Optional arguments	mcc18 [options] <i>file</i> [options]
Curly brackets and pipe character: { }	Choice of mutually exclusive arguments; an OR selection	errorlevel {0 1}
Ellipses...	Replaces repeated text	var_name [, var_name...]
	Represents code supplied by user	void main (void) { ... }
Notes	A Note presents information that we want to re-emphasize, either to help you avoid a common pitfall or to make you aware of operating differences between some device family members. A Note can be in a box, or when used in a table or figure, it is located at the bottom of the table or figure.	<div style="border: 1px solid black; padding: 5px; margin-bottom: 5px;"> <p>Note: This is a standard note box.</p> </div> <div style="border: 1px solid black; padding: 5px; margin-bottom: 5px;"> <p style="text-align: center;">CAUTION</p> <p>This is a caution note.</p> </div> <p>Note 1: This is a note used in a table.</p>

RECOMMENDED READING

This user's guide describes how to use the RN131/RN171/RN1723 Evaluation Kits. The following Microchip documents are available and are recommended as supplemental reference resources.

RN131 Module Data Sheet (DS70005085)

RN171 Module Data Sheet (DS70005084)

RN1723 Module Data Sheet (DS70005224)

Consult these documents for detailed information on the specific modules. Reference information found in these data sheets includes:

- Device pinout and packaging details
- Device electrical specifications
- List of features included on the module

PICDEM™ PIC18 Explorer Demonstration Board User's Guide (DS51721)
Explorer 16 Development Board User's Guide (DS50001589)

These documents describe how to use the demonstration or development board as a tool to emulate and debug firmware on a target board. Reference information found in these user's guides includes:

- Functionality and features
- Hardware features
- Development board schematics

WiFly Command Reference, Advanced Features and Applications User's Guide (DS50002230)

This user's guide provides information for configuring WiFly modules, including a command reference, advanced features, and applications.

THE MICROCHIP WEB SITE

Microchip provides online support via our web site at: <http://www.microchip.com>. This web site makes files and information easily available to customers. Accessible by most Internet browsers, the web site contains the following information:

- **Product Support** – Data sheets and errata, application notes and sample programs, design resources, user's guides and hardware support documents, latest software releases and archived software
- **General Technical Support** – Frequently Asked Questions (FAQs), technical support requests, online discussion groups, Microchip consultant program member listings
- **Business of Microchip** – Product selector and ordering guides, latest Microchip press releases, listings of seminars and events; and listings of Microchip sales offices, distributors and factory representatives

DEVELOPMENT SYSTEMS CUSTOMER CHANGE NOTIFICATION SERVICE

Microchip's customer notification service helps keep customers current on Microchip products. Subscribers will receive e-mail notification whenever there are changes, updates, revisions or errata related to a specified product family or development tool of interest.

To register, access the Microchip web site at www.microchip.com, click on Customer Change Notification and follow the registration instructions.

The Development Systems product group categories are:

- **Compilers** – The latest information on Microchip C compilers and other language tools
- **Emulators** – The latest information on the Microchip in-circuit emulator, MPLAB[®] REAL ICE™ in-circuit emulator
- **In-Circuit Debuggers** – The latest information on the Microchip in-circuit debugger, MPLAB ICD 3
- **MPLAB X IDE** – The latest information on Microchip MPLAB X IDE, the Windows[®] Integrated Development Environment for development systems tools
- **Programmers** – The latest information on Microchip programmers including the PICkit™ 3 development programmer

CUSTOMER SUPPORT

Users of Microchip products can receive assistance through several channels:

- Distributor or Representative
- Local Sales Office
- Field Application Engineer (FAE)
- Technical Support

Customers should contact their distributor, representative or field application engineer (FAE) for support. Local sales offices are also available to help customers. A listing of sales offices and locations is included in the back of this document.

Technical support is available through the web site at: <http://support.microchip.com>

DOCUMENT REVISION HISTORY

Revision A (August 2013)

This is the initial released version of the document.

Revision B (May 2015)

This revision includes the following updates:

- The document title was changed to: RN131/RN171/RN1723 Evaluations Kits User's Guide
- The document was extensively revised to include the RN1723 Evaluation Kit
- Minor updates to text and formatting were incorporated throughout the document

NOTES:

Chapter 1. Overview

This chapter describes the RN evaluation boards that are used for demonstrating the capabilities of the RN131, RN171, and RN1723 modules. These RN evaluation boards have the flexibility to connect directly to a PC or laptop through a standard USB interface or to embedded controllers through the serial UART interface.

Note: It is important to note that the RN131, RN171, and RN1723 Evaluation Boards share approximately 95% of their features. Therefore, most of the features described in this document will be common across all three platforms. Throughout this document, whenever a feature or description is common across all evaluation kits, that feature will be described collectively as “RN evaluation kit(s)”, “RN evaluation board(s)”, or “RN module(s)”, rather than repeating RN131/RN171/RN1723 when referring to either an evaluation kit, evaluation board, or module.

Refer to “**Recommended Reading**” for data sheet references and other resources. Additional information is available from the Embedded Wi-Fi page on the Microchip web site at: <http://www.microchip.com/wifi>.

This chapter includes the following topics:

- [RN Evaluation Kit Contents and Part Numbers](#)
- [Example Code and Related Information](#)
- [RN Evaluation Kit Hardware](#)
- [RN Evaluation Board Features](#)
- [RN Evaluation Board Components](#)

1.1 RN EVALUATION KIT CONTENTS AND PART NUMBERS

Depending on the RN evaluation kit ordered, the package contents contain one of the following RN evaluation boards and a USB cable:

- RN131 Evaluation Kit (P/N: RN-131-EK)
- RN171 Evaluation Kit (P/N: RN-171-EK)
- RN1723 Evaluation Kit (P/N: RN-1723-EK)

1.2 EXAMPLE CODE AND RELATED INFORMATION

Example code and other related information for each RN evaluation kit can be obtained from the Microchip web site at: <http://www.microchip.com/wifi>.

Note: RN module firmware can be upgraded to the latest version through an FTP update. For additional information on FTP updates and commands, refer to the “*WiFly Command Reference, Advanced Features and Applications User's Guide*” (DS50002230), which is available from the Microchip web site at: <http://www.microchip.com>.

RN131/RN171/RN1723 Evaluation Kits User's Guide

1.3 RN EVALUATION KIT HARDWARE

The RN evaluation boards contain two push buttons, which are labeled RESET/RST and FN (see **Note**). The RESET/RST button is used to reset the RN module and the FN button is used to launch different modes depending on the software configuration.

Note: On the RN131 Evaluation Board, the push button to reset the board is labeled RESET, whereas on the RN1723 and RN171 Evaluation Boards, this push button is labeled RST.

In addition to the push buttons, four status LEDs are provided to enable quick debug support.

The analog sensor interface supported by all of the RN evaluation boards also provides direct connections to read analog signals such as temperature and acceleration.

The RN171 Evaluation Board and the RN1723 Evaluation Board, in addition to the USB cable, can be powered through a battery pack (two AAA batteries).

[Table 1-1](#) provides an overview of the RN evaluation kit hardware.

TABLE 1-1: RN131/171/1723 EVALUATION KIT HARDWARE

Hardware	Description	RN-131-EK	RN-171-EK and RN-1723-EK
RN Evaluation Board	Contains the WiFly module and connectors	RN131 Module	RN171 or RN1723 Module
Power Up	Interface for powering up the RN evaluation boards	USB	USB or Battery Pack
LEDs	To indicate status and for debugging	Available	Available
Push Buttons	For launching applications	Available	Available
Sensor Interface	On board ADC provides direct connections to read analog signals such as temperature, acceleration and so on	Available	Available
Communication Interface	UART	Available	Available
USB Connector On-board	Provides power to the RN evaluation board and supports communication (COM Port)	Available	Available
SMA Connectors	U.FL and reverse SMA connectors	Available	Not Available

1.4 RN EVALUATION BOARD FEATURES

1.4.1 RN131 Evaluation Board Features

The RN131 Evaluation Board has the following features:

- Supports the FCC/CE/IC certified 2.4 GHz IEEE 802.11 b/g RN131 module
- Wi-Fi® Alliance certified for WPA2-PSK and RoHS compliant
- Complete on-board TCP/IP networking stack through the RN module
- Supports infrastructure networking modes along with the SoftAP mode
- Built-in networking applications through the RN module, such as TCP/IP, DHCP, DNS, ARP, UDP, Telnet, FTP client, and HTML client
- Configuration over Wi-Fi or UART using simple ASCII commands
- Supports 921 Kbps TX, 500 Kbps RX data rates with TCP/IP and WPA2 over UART
- Powered by a USB cable (5V)
- Push buttons for launching Applications and RESET signal
- Real-time clock for wake up and time stamping
- On-board ceramic chip antenna and a U.FL. connector
- Size – 50.8 mm x 28 mm x 5 mm

1.4.2 RN1723 Evaluation Board and RN171 Evaluation Board Features

Note: The RN1723 Evaluation Board has the same functionality as the RN171 Evaluation Board; however, the major difference is that three additional commands were added to the WiFly command set, as well as a GPIO function change in the RN1723 module. Refer to the “*WiFly Command Reference, Advanced Features and Applications User’s Guide*” (DS50002230) for information. This document is available from the Microchip web site at: <http://www.microchip.com>.

The RN1723 Evaluation Board and RN171 Evaluation Board have the following features:

- Supports the FCC/CE/IC certified 2.4 GHz IEEE 802.11 b/g RN1723/RN171 module
- Wi-Fi Alliance certified for WPA2-PSK and RoHS compliant
- Complete on-board TCP/IP networking stack through the RN module
- Supports SoftAP and Infrastructure networking modes
- Built-in networking applications through the RN module, such as TCP/IP, DHCP, DNS, ARP, UDP, Telnet, FTP client and HTML client
- Configuration over Wi-Fi or UART using simple ASCII commands
- Supports 921 Kbps TX, 500 Kbps RX data rates with TCP/IP and WPA2 over UART
- Powered by 3.3V battery pack (two AAA batteries) or through a USB cable (5V)
- Push buttons for launching Applications and RESET signal
- 10 general purpose digital I/O pins
- Eight analog sensor interfaces; configurable sensor power outputs 0-3.3V DC
- Real-time clock for wake-up and time stamping
- Trace antenna
- Size – 50.8 mm x 28 mm x 20 mm

RN131/RN171/RN1723 Evaluation Kits User's Guide

1.5 RN EVALUATION BOARD COMPONENTS

1.5.1 RN131 Evaluation Board

Figure 1-1 shows the components of the RN131 Evaluation Board. Table 1-2 through Table 1-4 provide pin information for the UART and Sensor interfaces, as well as LED descriptions.

FIGURE 1-1: RN131 EVALUATION BOARD COMPONENTS

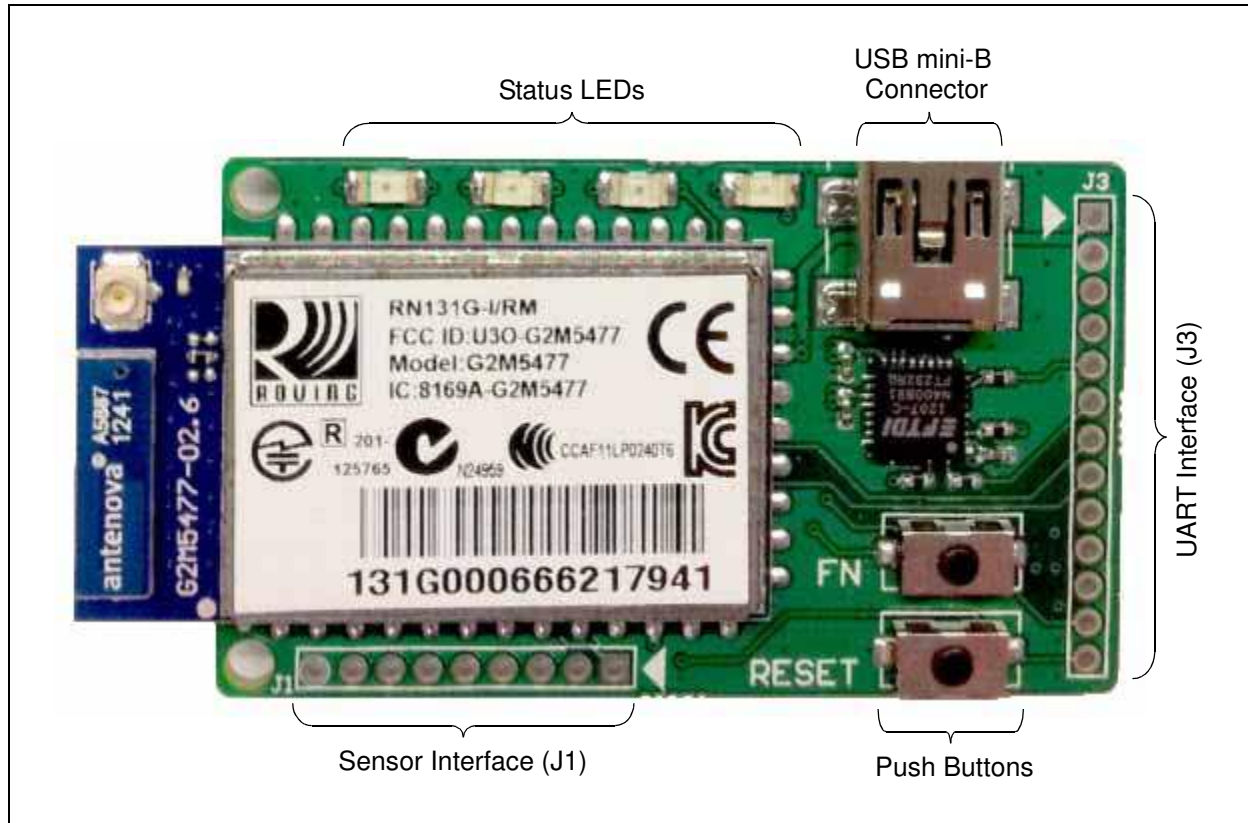
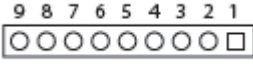

TABLE 1-2: RN131 UART INTERFACE (J3) PIN TABLE

Diagram	Pin	Description
	1	3.3V DC Output
	2	Ground
	3	UART Receive (RX)
	4	UART Transmit (TX)
	5	UART Receive-to-Send (RTS)
	6	UART Clear-to-Send (CTS)
	7	GPIO4
	8	GPIO5
	9	GPIO6
	10	GPIO7
	11	GPIO8
	12	GPIO9 (internally connected to FN)
	13	RESET

TABLE 1-3: RN131 SENSOR INTERFACE (J1) PIN TABLE

Diagram	Pin	Description
	1	Sensor Power
	2	Sensor 4 (3.3V tolerant)
	3	Sensor 5 (3.3V tolerant)
	4	Sensor 7 (1.2V only)
	5	Sensor 5 (1.2V only)
	6	Sensor 4 (1.2V only)
	7	Sensor 6 (1.2V only)
	8	Sensor 3 (1.2V only)
	9	Ground

WARNING

Voltage on pins marked 1.2V only should not exceed more than 1.2V DC. Failure to heed this warning will result in permanent damage to the RN evaluation board.

TABLE 1-4: RN131 EVALUATION BOARD LED INDICATORS

Condition	Blue LED	Red LED	Yellow LED	Green LED
On	Unused	—	—	Connected over TCP
Fast Blink	Unused	Not Associated	RX/TX Data Transfer	No IP address
Slow Blink	Unused	Associated, no Internet	—	IP address OK
Off	Unused	Associated, Internet OK	—	—

1.5.2 RN1723 and RN171 Evaluation Boards

Figure 1-2 and Figure 1-3 show the components of the RN1723 Evaluation Board and RN171 Evaluation Board, respectively. Table 1-5 through Table 1-7 provide pin information for the UART and Sensor interfaces, as well as LED descriptions, which are common to both evaluation boards.

FIGURE 1-2: RN1723 EVALUATION BOARD COMPONENTS

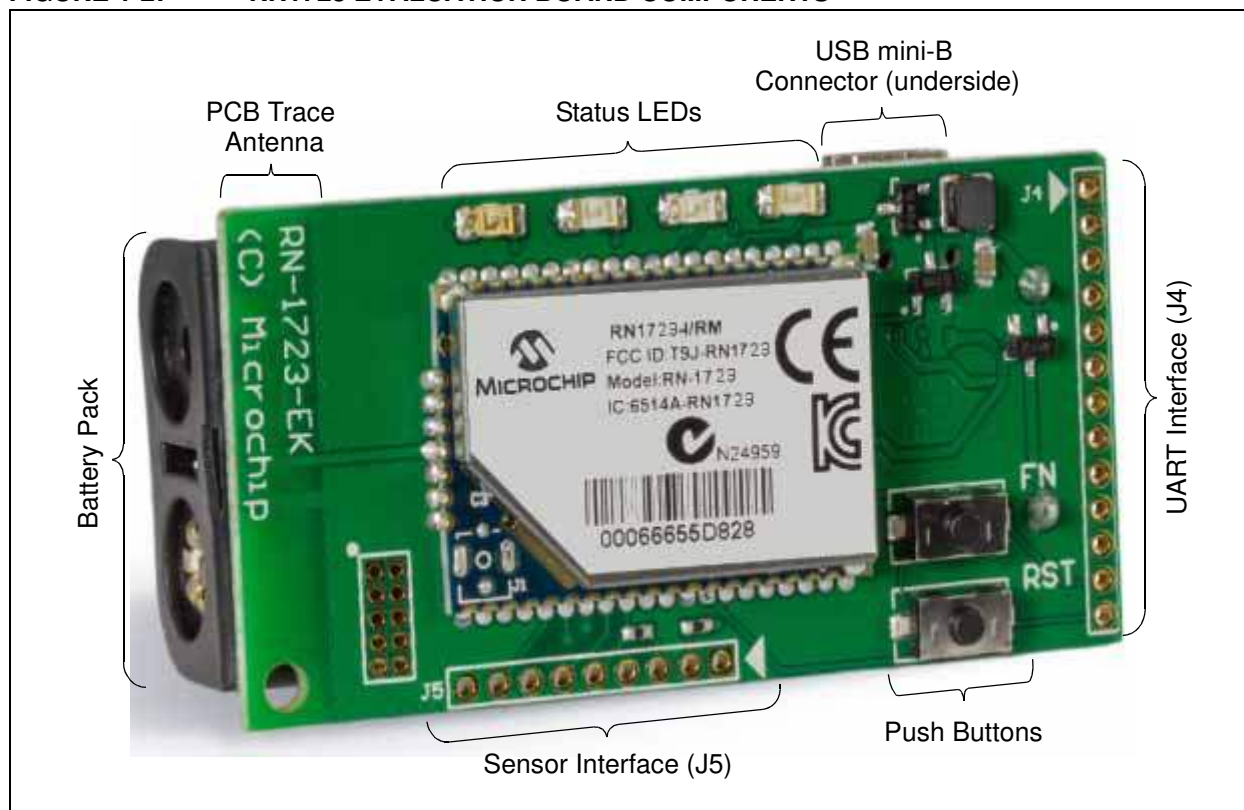

FIGURE 1-3: RN171 EVALUATION BOARD COMPONENTS

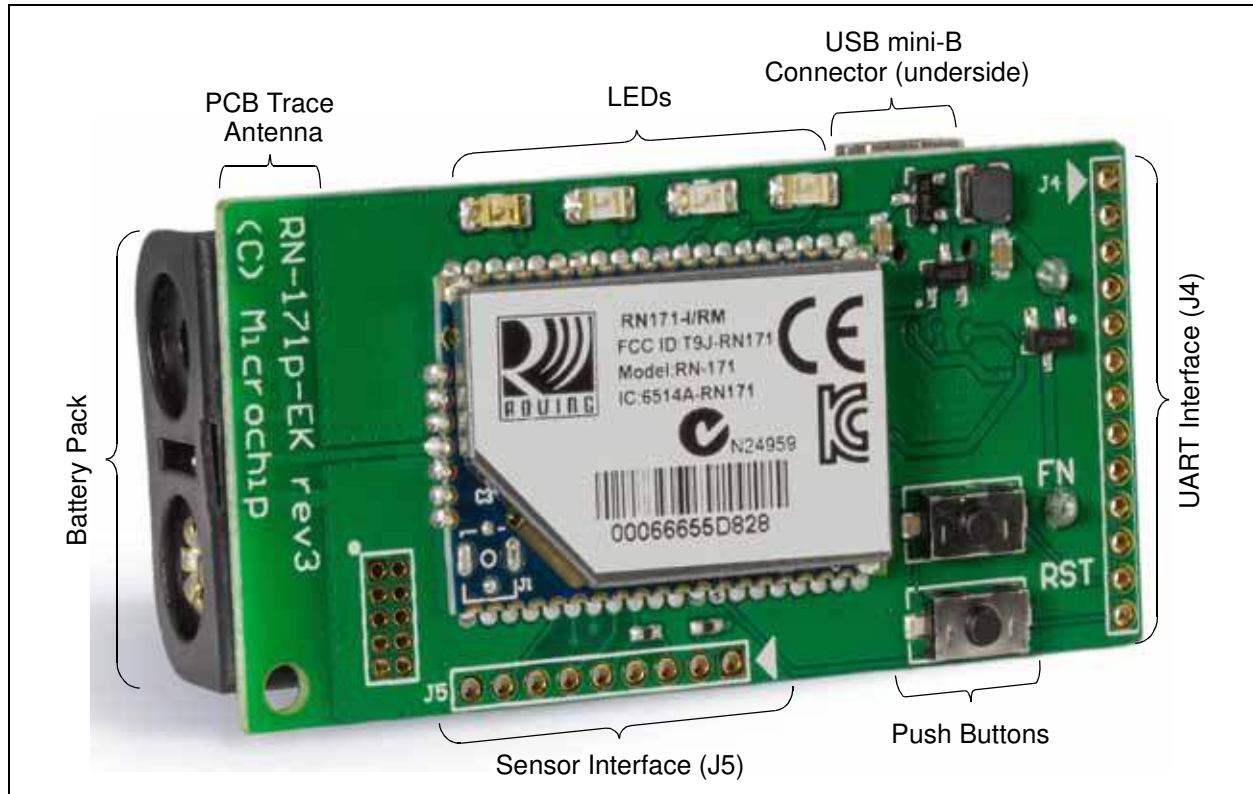
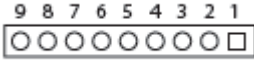

TABLE 1-5: RN1723 AND RN171 UART INTERFACE (J4) PIN TABLE

Diagram	Pin	Description
	1	3.3V DC Output
	2	Ground
	3	UART Receive (RX)
	4	UART Transmit (TX)
	5	UART Receive-to-Send (RTS)
	6	UART Clear-to-Send (CTS)
	7	GPIO4
	8	GPIO5
	9	GPIO6
	10	GPIO7
	11	GPIO8 (see Note 1)
	12	GPIO9 (internally connected to FN)
	13	RESET

Note 1: The RN1723 and RN171 modules drive GPIO8 High on power-up, which overrides software configured power-up values, such as: `set sys value 0x0000 on GPIO8.`

TABLE 1-6: RN1723 AND RN171 SENSOR INTERFACE (J5) PIN TABLE

Diagram	Pin	Description
	1	Sensor Power
	2	Sensor 4 (3.3V tolerant)
	3	Sensor 5 (3.3V tolerant)
	4	Sensor 7 (1.2V only)
	5	Sensor 5 (1.2V only)
	6	Sensor 4 (1.2V only)
	7	Sensor 6 (1.2V only)
	8	Sensor 3 (1.2V only)
	9	Ground

WARNING
Voltage on pins marked 1.2V only should not exceed more than 1.2V DC. Failure to heed this warning will result in permanent damage to the RN evaluation board.

Table 1-7 lists the LED indicators common to all RN evaluation boards.

TABLE 1-7: RN1723 AND RN171 EVALUATION BOARD LED INDICATORS

Condition	Blue LED	Red LED	Yellow LED	Green LED
On	Unused	—	—	Connected over TCP
Fast Blink	Unused	Not Associated	RX/TX Data Transfer	No IP address
Slow Blink	Unused	Associated, no Internet	—	IP address OK
Off	Unused	Associated, Internet OK	—	—

Chapter 2. Getting Started

This chapter describes using an RN evaluation kit as an independent platform for exploring the ASCII command set and prototyping of embedded systems. Certain hardware and software/utilities are essential to support the development of demonstration applications.

This chapter includes the following topics:

- [Prerequisites](#)
- [Hardware Configuration](#)
- [Module Configuration](#)

2.1 PREREQUISITES

2.1.1 Software

The following software tools/utilities are required to run the demonstration applications:

- A Terminal Emulator application such as TeraTerm (for Windows 7 or later) or CoolTerm (for Mac OS X or later)

Note: A Terminal Emulator application is used to send the configuration commands to the RN module over a UART interface. The emulator also displays information transmitted from the RN module.

- The RN evaluation boards use the FTDI Chipset. Windows automatically installs the drivers for the USB serial cable. However, if the drivers are not automatically installed, download and install the FTDI Chipset drivers from the Microchip web site as described in [2.2 “Hardware Configuration”](#). Once the FTDI Chipset drivers are installed, the COM port is automatically assigned based on the active connection

2.1.2 Hardware

To set up and run the demonstration applications, the following hardware is required:

- PC or laptop running one of these operating systems:
 - Windows 7 or later
 - Mac OS X or later
- RN evaluation board
- USB cable

2.2 HARDWARE CONFIGURATION

The following steps describe how to set up and configure the hardware:

1. Supply power to the evaluation board using a USB cable. Alternatively, power can be supplied to the RN1723 Evaluation Board and RN171 Evaluation Board by inserting two AAA batteries into the battery pack.
2. Connect the USB cable to a USB port on the host system and to the USB connector on the RN evaluation board.
3. If the drivers are not automatically installed, download and install the FTDI Chipset drivers from <http://www.microchip.com/wifi>. From the Wireless menu, click **Firmware** and scroll to the Software section. Click **FTDI Chipset Drivers** to download the zip archive.

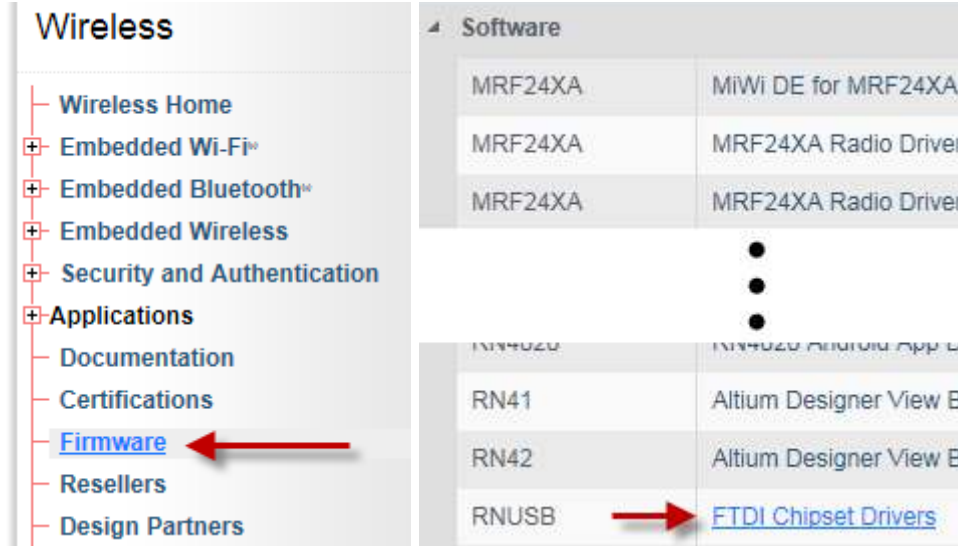

4. Once the FTDI drivers are installed, the COM port is automatically assigned based on the active connection.

2.3 MODULE CONFIGURATION

The RN modules of the evaluation boards operate in two modes:

- Data mode (default)
- Command mode

2.3.1 Data Mode

In Data mode, an RN module is essentially a data pipe. When the RN module receives data over Wi-Fi, it strips the TCP/IP headers and trailers, and passes the user data to the UART. When data is written to the UART, the RN module constructs the TCP/IP packet and sends it out over Wi-Fi. Therefore, the entire process of sending/receiving data to the host is transparent to the microcontroller of the end-application/user.

2.3.2 Command Mode

By default, the RN module is in Data mode. Sending an escape sequence of three \$\$\$ characters causes the RN module to enter Command mode. Once in Command mode, the RN module can be configured using simple ASCII commands. To exit Command mode and return to Data mode, type `exit` and press <Enter>.

Basic configuration requires the wireless network access point's name (SSID) and the authentication password. The RN module can associate with only one network at a time. It is recommended to begin evaluation by configuring the RN module using an open access point to simplify the setup.

The following two methods are used to configure the RN module:

- Over the UART connected to a PC/laptop or to a microcontroller
- Through Wi-Fi using Soft AP mode

A terminal emulator is required to enter the commands and to monitor the transactions.

Figure 2-1 shows an application interface for Data and Command modes.

FIGURE 2-1: APPLICATION INTERFACE FOR DATA AND COMMAND MODES

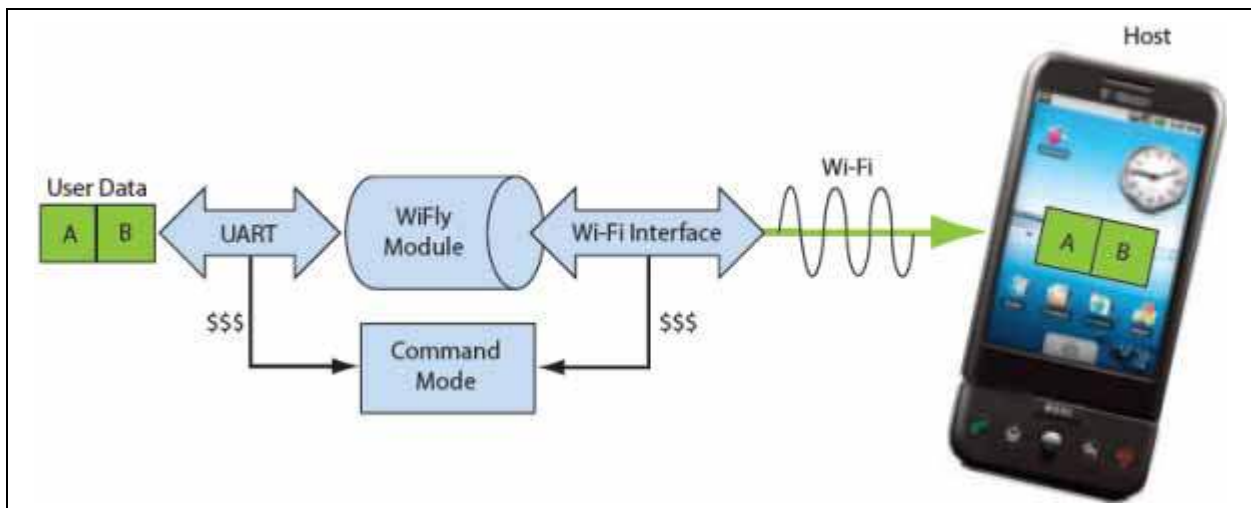

2.3.3 Configuration Using a USB Cable

Evaluation boards use a USB cable to allow the host computer to communicate with the on-board RN module.

The following instructions describe how to use a terminal emulator to enter Configuration mode, send commands to find networks, associate with an access point, and save the configuration.

2.3.3.1 CONFIGURE THE MODULE USING A TERMINAL EMULATOR

Either the TeraTerm (for Windows 7 or later) or CoolTerm (for Mac OS X or later) terminal emulator applications can be used. Also, legacy evaluation boards use a USB-to-serial cable for connecting the evaluation board to the PC/laptop. When using any of the evaluation boards, use the COM port to which the USB-to-serial cable is connected.

Use the following steps to communicate with an RN module using a terminal emulator:

1. Determine the COM port that is assigned to the USB cable (the port is COM9 in the example shown in [Figure 2-2](#)).
2. Open the available terminal emulation application and specify the COM port.
3. When using TeraTerm, open the Serial option and select the COM port number from the drop-down menu.
4. The serial port with the required settings are as follows:
 - Baud: 9600
 - Data bits: 8
 - Parity: None
 - Stop bits: 1
 - Flow control: None
5. Type the commands through the terminal emulator application and to the assigned program.

Note: The COM port number can be found as follows:

- For Windows: Go to the Windows Device Manager from System Tools. In the Device Manager, browse and expand the selection for serial ports (COM & LPT). Use TeraTerm for other configuration settings and monitoring.
- For Mac: When using CoolTerm, view and select the port from the same terminal emulator application.

FIGURE 2-2: FINDING THE COM PORT NUMBER IN WINDOWS

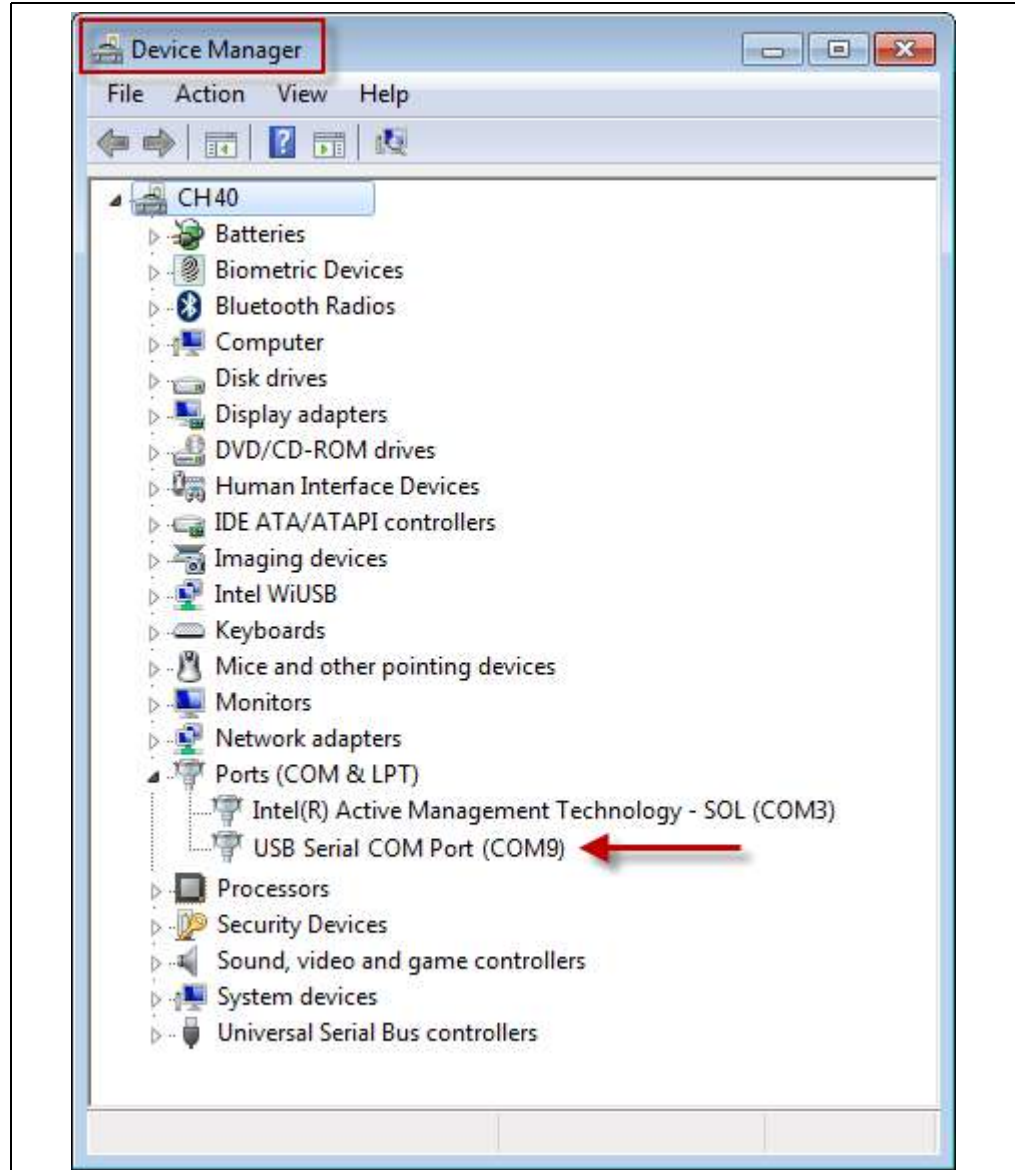

2.3.3.2 ENTER COMMAND MODE

The following steps provide an example for entering Command mode through a terminal emulator on the RN171 Evaluation Board. The output will differ depending on which evaluation board is being accessed:

1. Type three \$\$\$ characters with no additional characters before or after each \$ character. The RN module replies with `CMD` on the terminal emulator to indicate it is in Command mode.
2. Type `show net` and press <Enter> to display the current network settings (Figure 2-3 shows the current network settings of the WiFly application).

Note: When a command is completed, the terminal displays a prompt in the format <x.xx>, where 'x.xx' indicates the RN module's firmware version.

FIGURE 2-3: CURRENT NETWORK SETTINGS

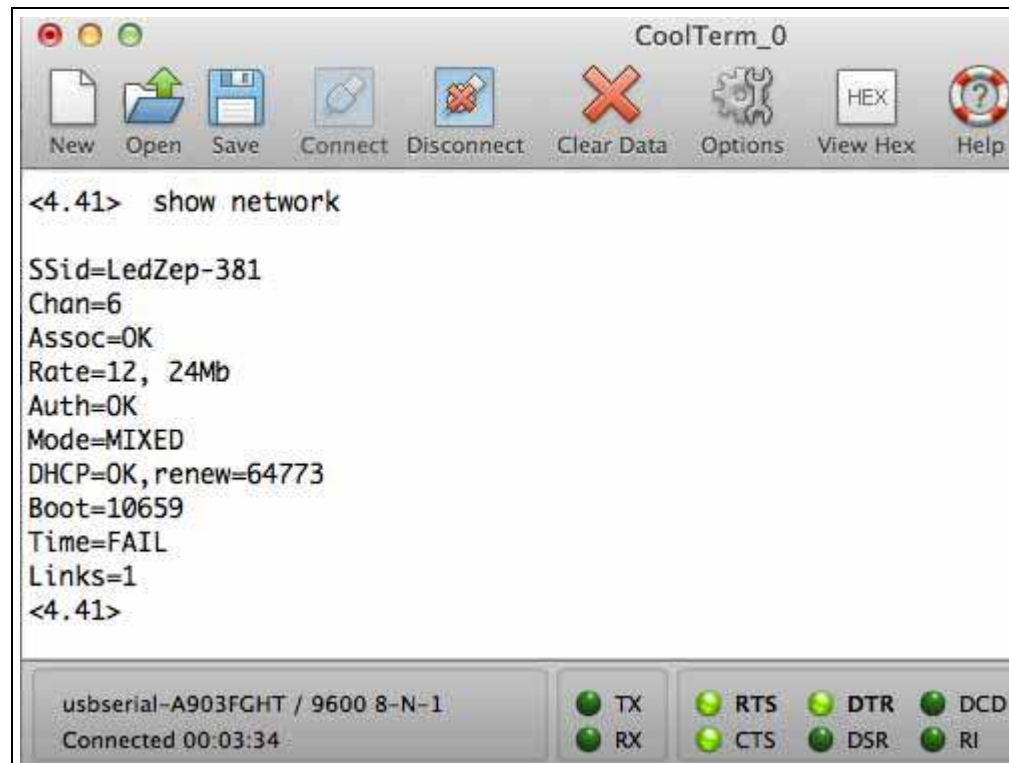

A command to the RN module is first sent with a keyword followed by an optional parameter. For example:

```
set uart baudrate 115200
```

The RN modules supports a variety of command keywords. The complete command reference is available in the *“WiFly Command Reference, Advanced Features and Applications User's Guide Reference”* (DS50002230), which is available from the Microchip web site at: <http://www.microchip.com>.

Chapter 3. Application Design Concerns

This section provides the design concerns related to powering an evaluation board, sensor interface settings, AP mode, and restoring factory settings.

The following topics are discussed:

- [Sensor Interfaces](#)
- [Push Button Functions](#)

3.1 SENSOR INTERFACES

The input voltage on the sensor inputs must not exceed 1.2V; otherwise, hardware damage could occur. The Analog-to-Digital Converter (ADC) saturates at 400 mV. It is recommended to use the sensor power output to drive any analog devices that are attached to the sensor pins.

Note: Sensor pins 2 and 3 have a resistor network in front of sensors 4 and 5, respectively. Therefore, these pins can be driven with up to 3.3V DC.

3.2 PUSH BUTTON FUNCTIONS

3.2.1 FN Push Button

The FN push button can be used to place the RN module into one of three modes: AP, Factory reset, and WPS.

3.2.1.1 AP MODE

AP mode allows all Wi-Fi-enabled devices to be associated with the RN module.

To put the RN module into AP mode, FN must be high when the RN module powers up or wakes from a sleep state. This is done by pressing the FN push button, and then pressing and releasing the RESET/RST push button, which resets the RN module and places it into AP mode. Now that the RN module is in AP mode, a default Wi-Fi network is created with the parameters listed in [Table 3-1](#).

Note: Using this method to place the RN module into AP mode will override any previous AP mode software settings.

TABLE 3-1: AP MODE DEFAULT SETTINGS

Setting	AP Mode Default
SSID	WiFly-xxx-yy Where 'xxx' is GSX for RN131, EZX for RN171, and FZX for RN1723 and 'yy' is the LSB of the module's MAC address.
Channel	1
DHCP Server	Enabled
IP Address	192.168.1.1
Netmask	255.255.255.0
Gateway	192.168.1.1

Once the RN module boots, other Wi-Fi-enabled devices will be able to locate the RN module whenever scanning for access points.

3.2.1.2 FACTORY RESET

In Factory Reset mode, an RN module is restored to the factory default condition. As shown in [Figure 1-1](#), [Figure 1-2](#), and [Figure 1-3](#) in **1.5 “RN Evaluation Board Components”**, the FN push button is used in conjunction with the RESET/RST push button to perform a factory reset.

3.2.1.3 WPS

The Wi-Fi Protected Setup (WPS) mode allows the RN module to be associated to the appropriate access point. WPS mode is entered by pressing and releasing the FN push button while the `launch_string` configuration parameter is set to `wps_app`. By default, the `launch_string` is set to `web_app`.

Refer to the “*WiFly Command Reference, Advanced Features and Applications User's Guide*” (DS50002230) for information. This document is available from the Microchip web site at: <http://www.microchip.com/wifi>.

3.2.2 RESET/RST Push Button

When the RESET/RST push button is pressed, the RN module will briefly power down and restart.

Appendix A. Schematics, Bill of Materials, and Dimensions

This appendix provides the schematics, Bill of Materials (BOM), and physical dimensions for the RN evaluation boards.

A.1 RN131 EVALUATION BOARD

FIGURE A-1: RN131 MODULE

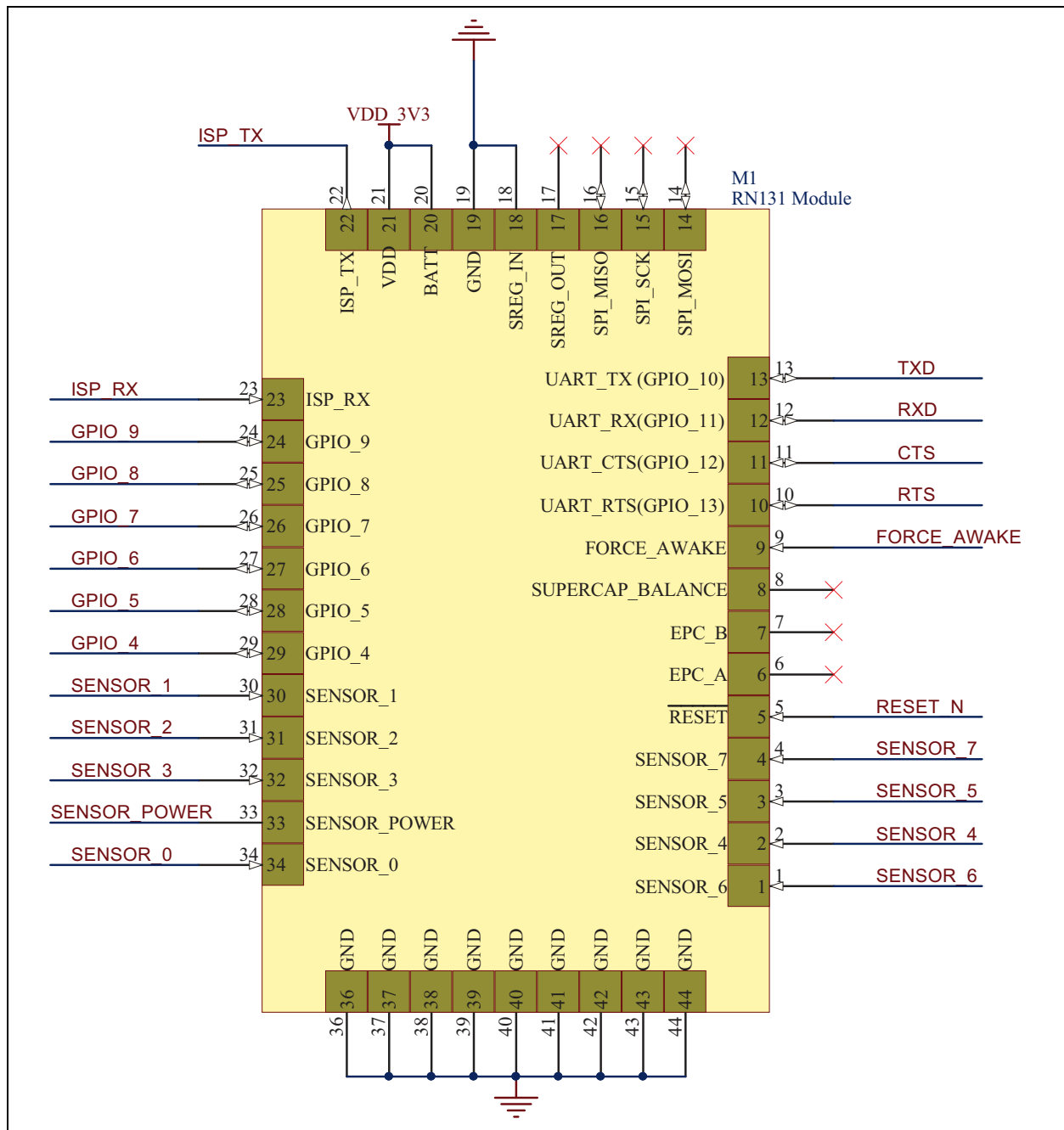

RN131/RN171/RN1723 Evaluation Kits User's Guide

FIGURE A-2: RN131 FTDI CHIPSET INTERFACE

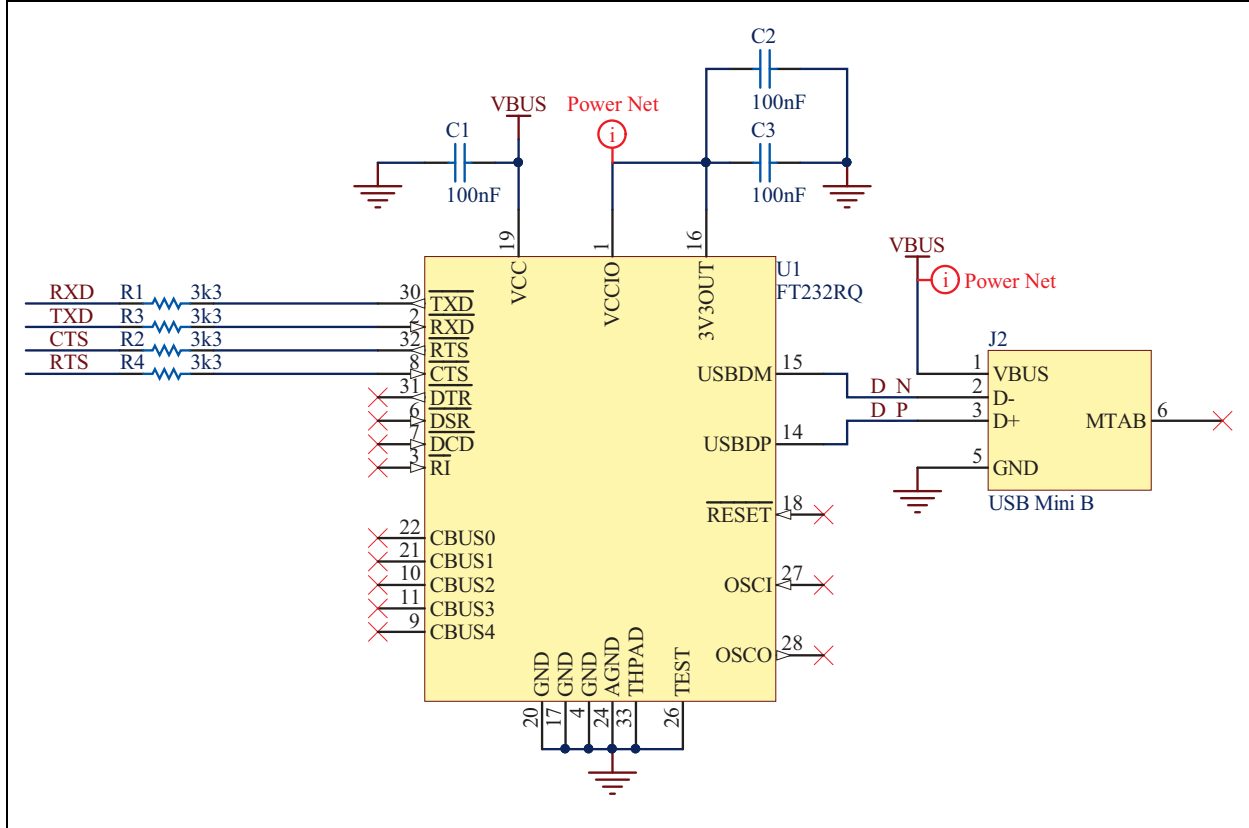
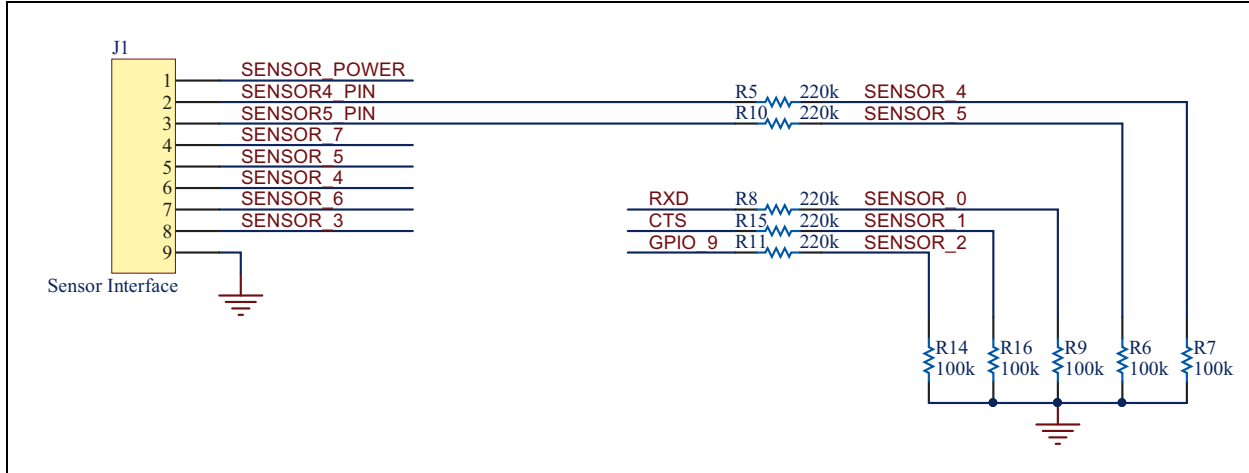

FIGURE A-3: RN131 SENSOR INTERFACE



Schematics, Bill of Materials, and Dimensions

FIGURE A-4: RN131 PUSH BUTTONS

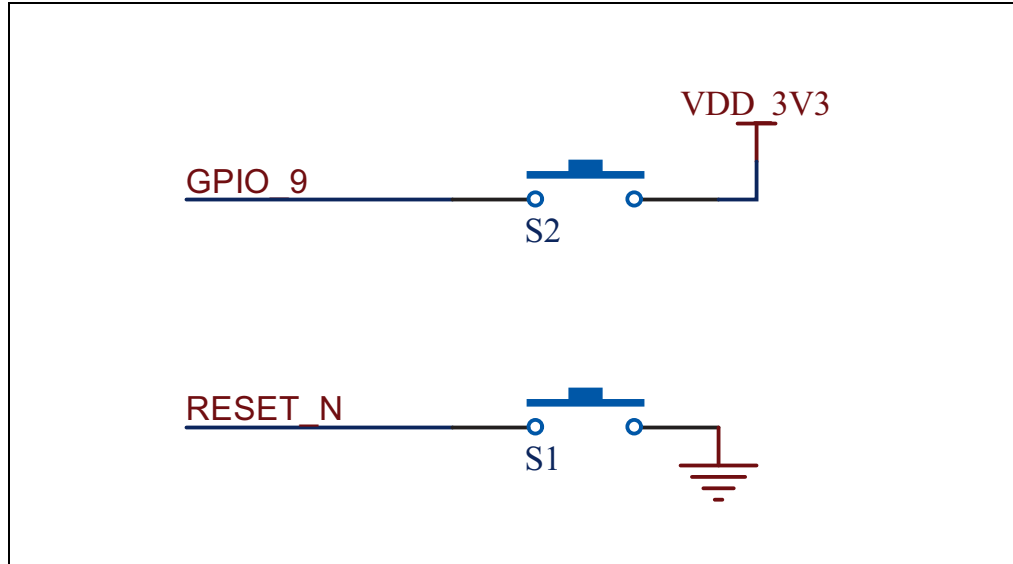

FIGURE A-5: RN131 UART INTERFACE

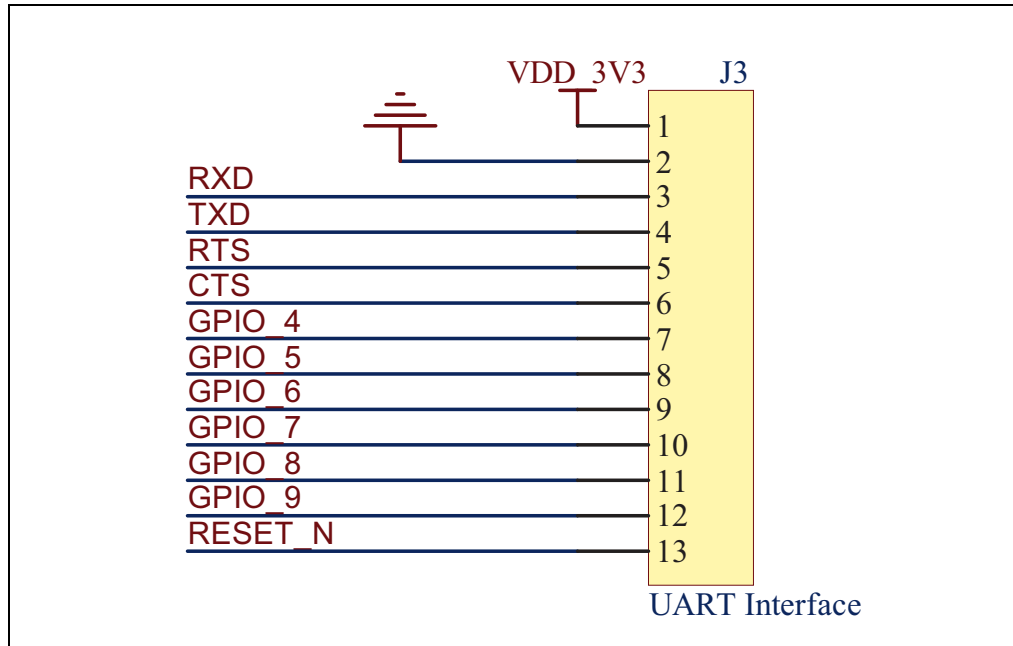

FIGURE A-6: RN131 ISP CONNECTOR

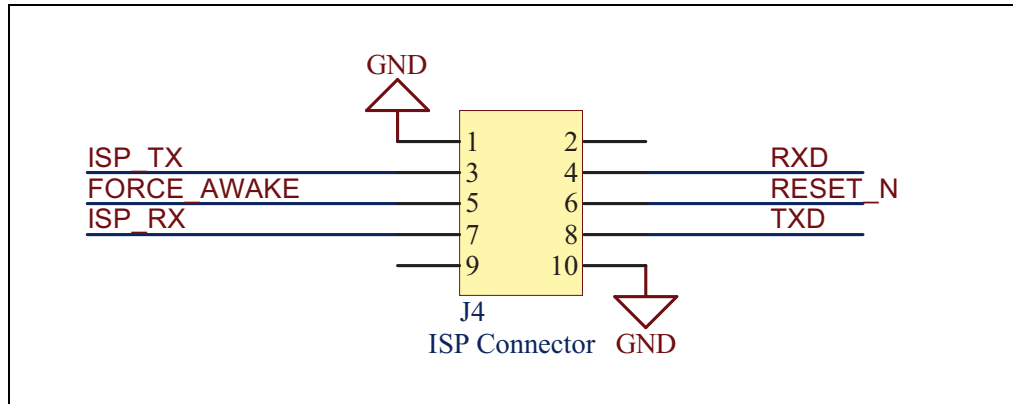

FIGURE A-7: RN131 USB CONNECTOR

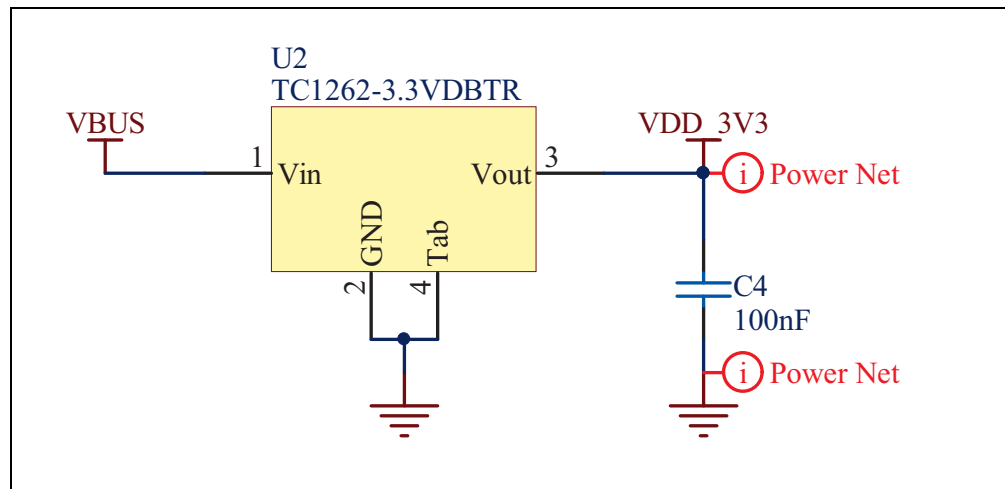
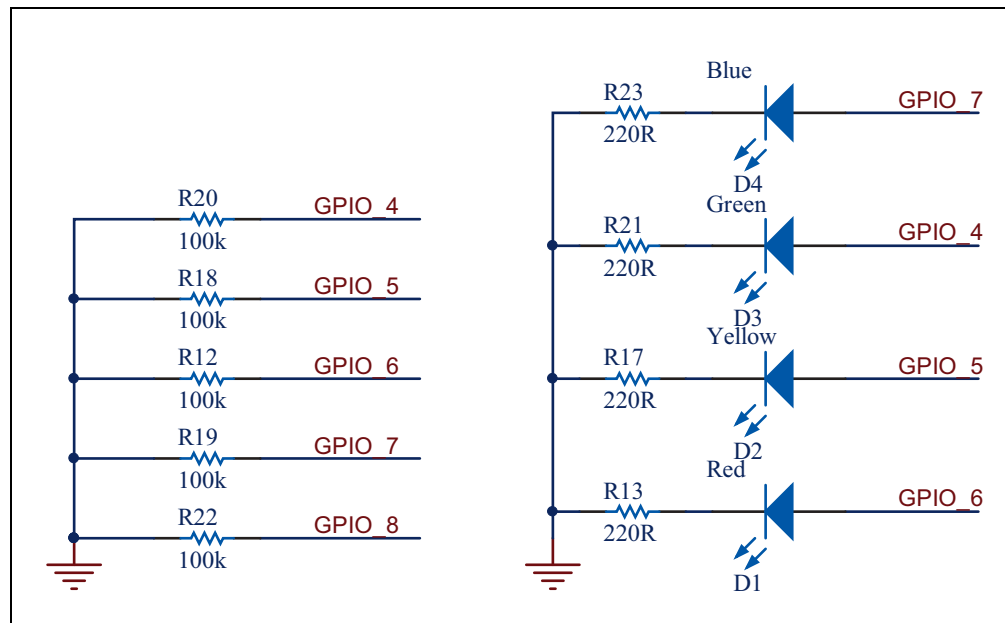

FIGURE A-8: RN131 LEDs



Schematics, Bill of Materials, and Dimensions

A.2 RN171 EVALUATION BOARD AND RN1723 EVALUATION BOARD

FIGURE A-9: RN171 MODULE AND RN1723 MODULE SCHEMATIC

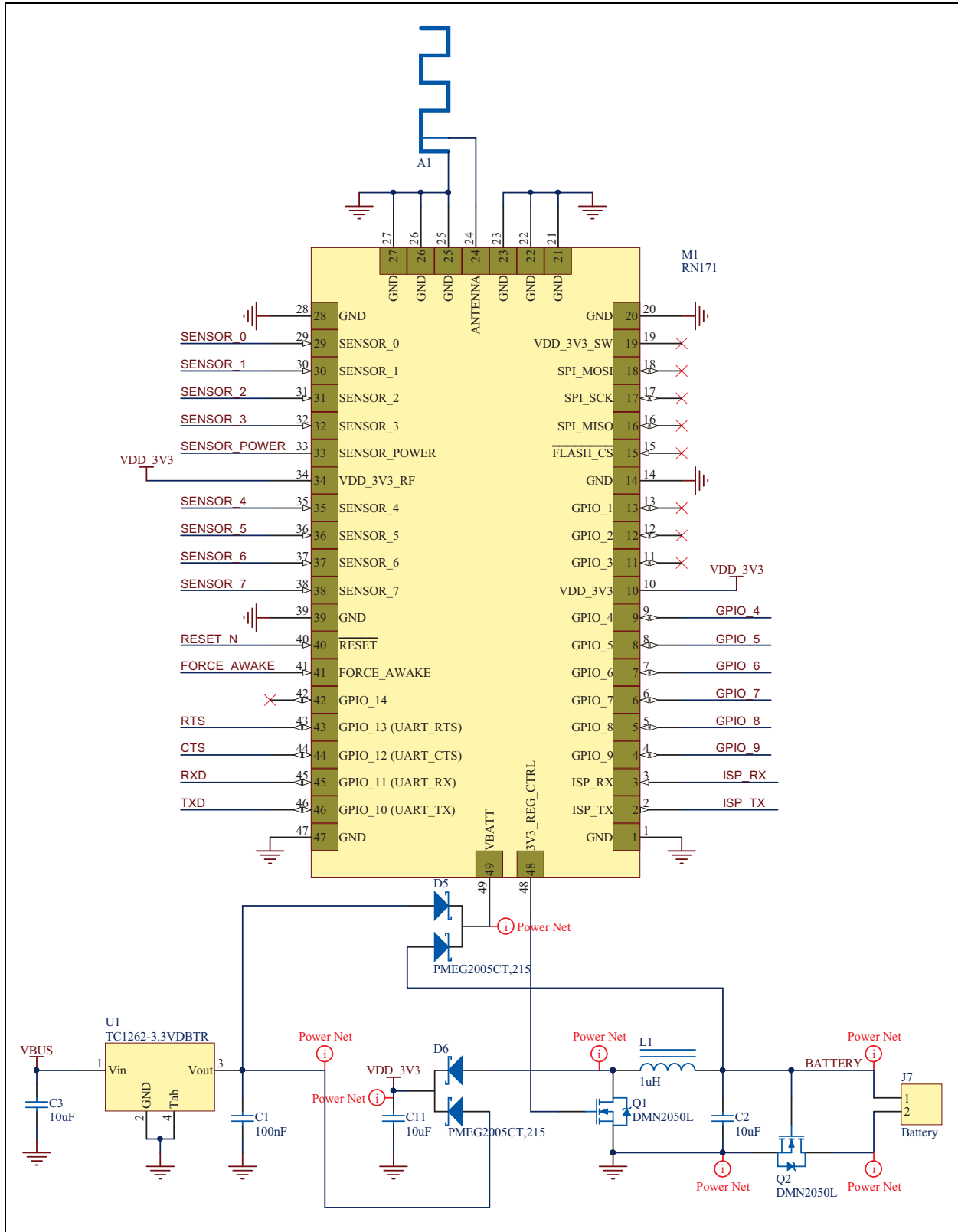

RN131/RN171/RN1723 Evaluation Kits User's Guide

FIGURE A-10: RN1723 AND RN171 FTDI CHIPSET INTERFACE

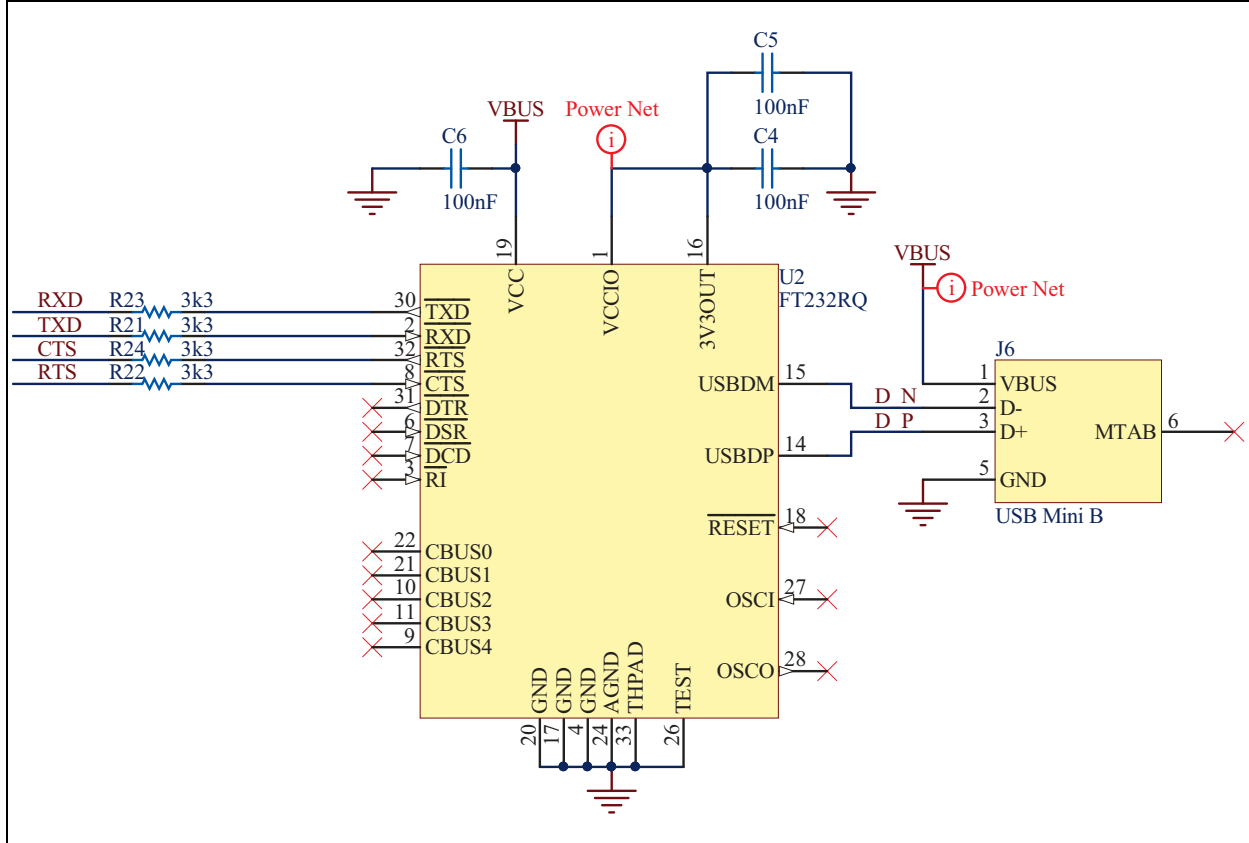
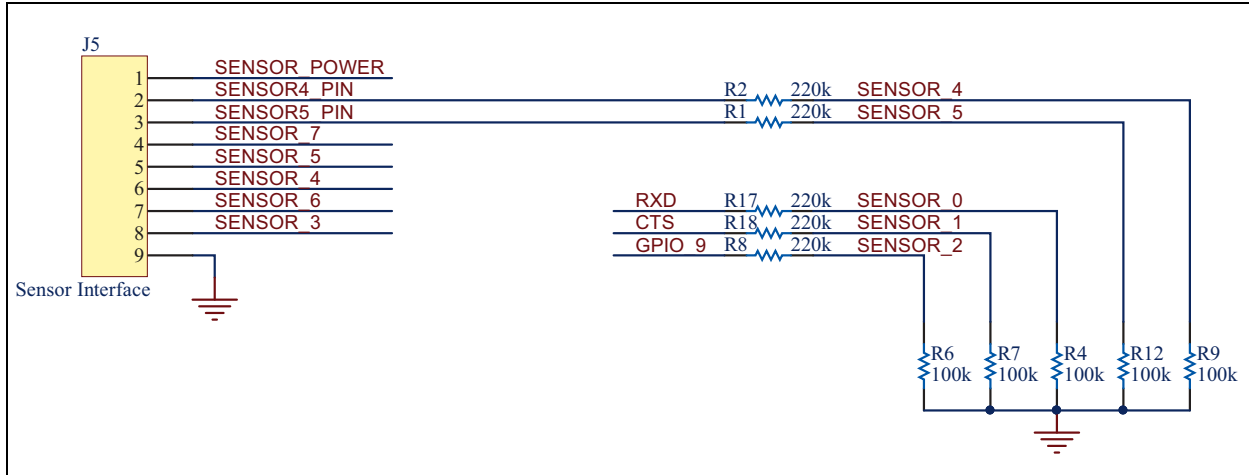

FIGURE A-11: RN1723 AND RN171 SENSOR INTERFACE



Schematics, Bill of Materials, and Dimensions

FIGURE A-12: RN1723 AND RN171 PUSH BUTTONS

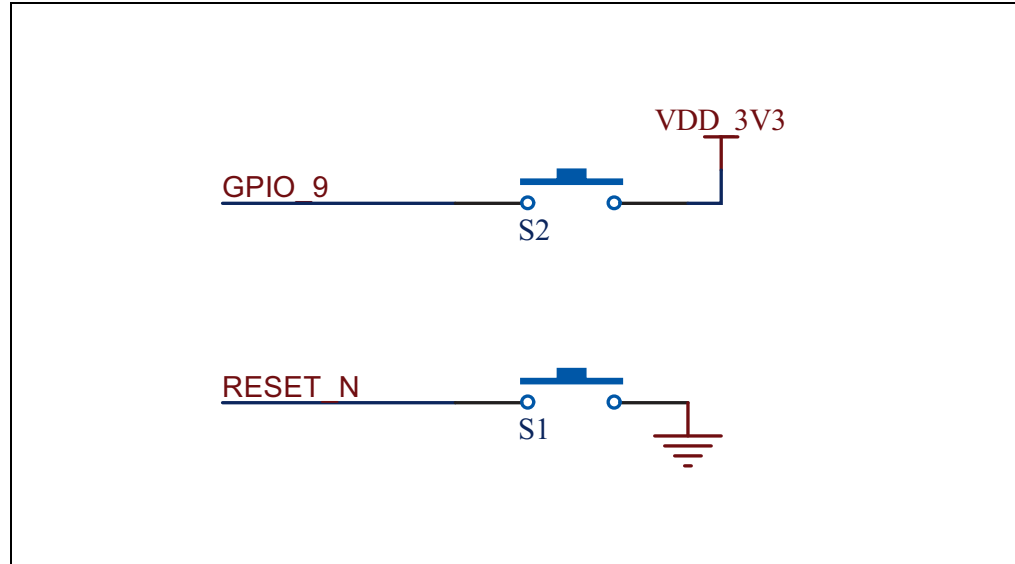

FIGURE A-13: RN1723 AND RN171 UART INTERFACE

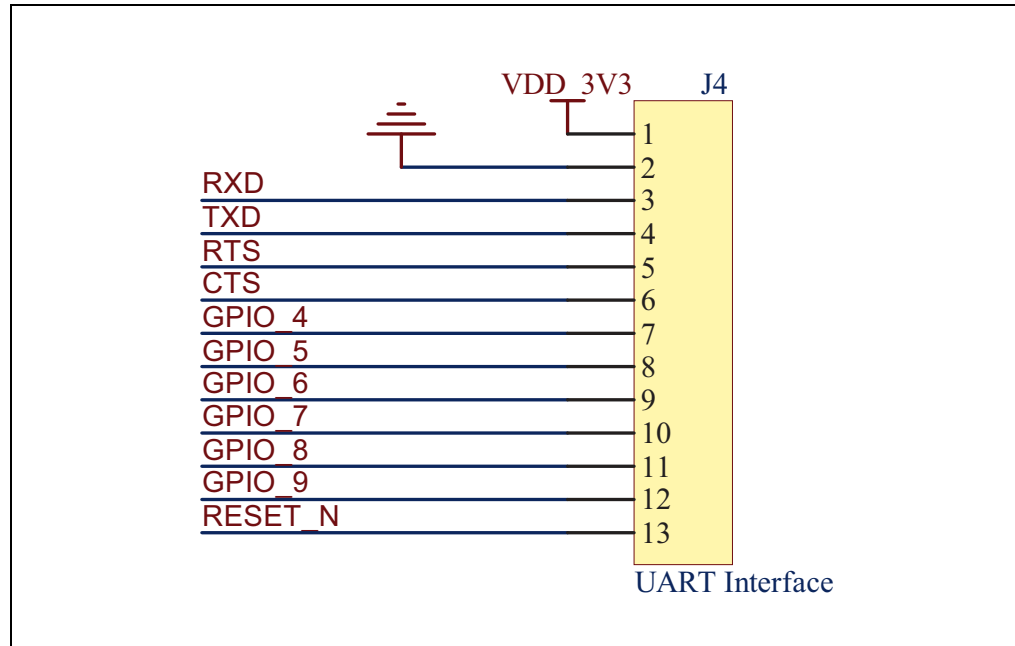

FIGURE A-14: RN1723 AND RN171 ISP CONNECTOR

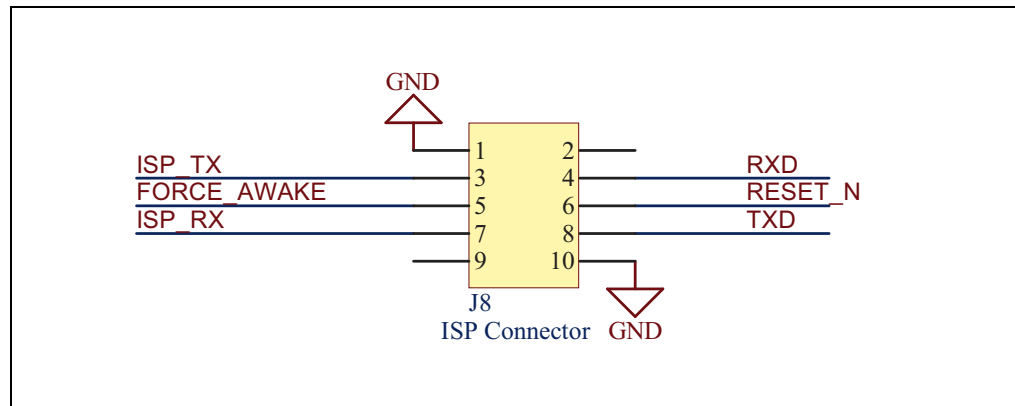
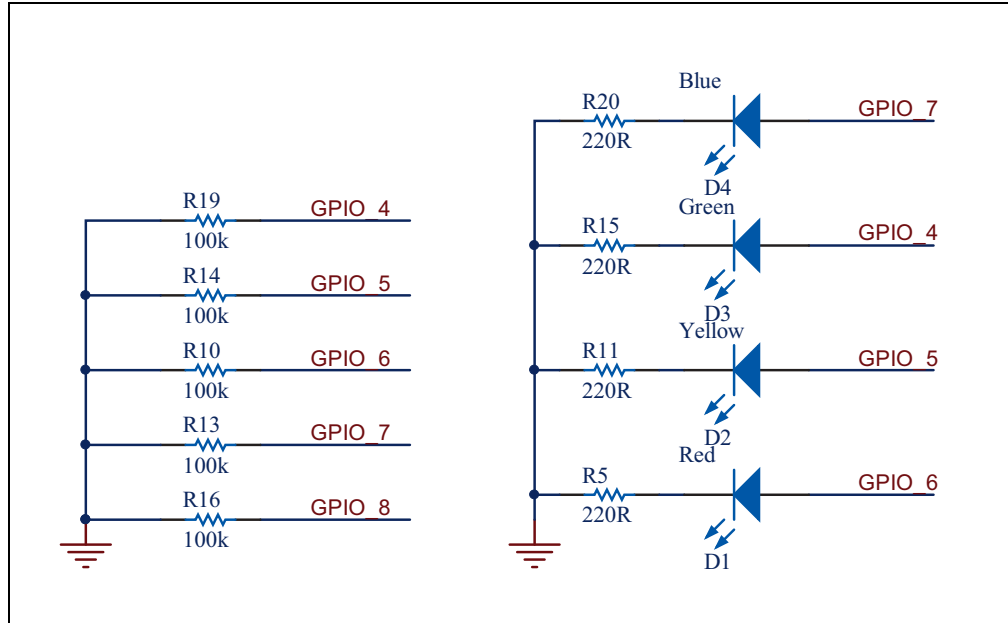

FIGURE A-15: RN1723 AND RN171 LEDs



Schematics, Bill of Materials, and Dimensions

A.3 BILL OF MATERIALS

TABLE A-1: RN131 EVALUATION BOARD BILL OF MATERIALS (BOM)

Reference	Value	Description	Vendor	Vendor P/N
C1, C2, C3	100 nF	Cap ceramic, -20%, 80%, 16V, Y5V, 0402	Yageo	CC0402ZRY5V7BB104
C4	100 nF	Cap ceramic, -20% / 80%, 16V, Y5V, 0603	Yageo	CC0603ZRY5V7BB104
D1	Red	Clear, Red LED, 10 mA, 1.8V, 638 nm, 130 degrees, 1206	Lite-On Inc.	LTST-C150CKT
D2	Yellow	Clear, Yellow LED, 10 mA, 2.1V, 588 nm, 130 degrees, 1206	Lite-On Inc.	LTST-C150YKT
D3	Green	Clear, Green LED, 10 mA, 2.1V, 569 nm, 130 degrees, 1206	Lite-On Inc.	LTST-C150GKT
D4	Blue	Clear, Blue LED, 20 mA, 3.3V, 470 nm, 130 degrees, 1206	Lite-On Inc.	LTST-C150TBKT
J2	USB mini-B	CONN USB RCPT MINI B 5PS R/A SMD	JAE	DX2R005HN2E700
M1	—	RN131 Module	Microchip Technology Inc.	RN-131
R1, R2, R3, R4	3k3	Res, 5%, 0.1W, 0402	Panasonic - ECG	ERJ-2GEJ332X
R5, R8, R10, R11, R15	220k	Res, 5%, 0.1W, 0402	Panasonic - ECG	ERJ-2GEJ224X
R6, R7, R9, R12, R14, R16, R18, R19, R20, R22	100k	Res, 5%, 0.1W, 0402	Panasonic - ECG	ERJ-2GEJ104X
R13, R17, R21, R23	220R	Res, 5%, 0.1W, 0402	Panasonic - ECG	ERJ-2GEJ221X
S1, S2	Push button	SWITCH TACTILE SPST-NO 0.05A 32V	C&K Components	KSR211J
U1	FT232RQ	IC USB FS SERIAL UART 32-QFN	FTDI	FT232RQ-REEL
U2	TC1262-3.3V	Linear Voltage Regulator	Microchip Technology Inc.	TC1262-3.3VDBTR

RN131/RN171/RN1723 Evaluation Kits User's Guide

TABLE A-2: RN171 EVALUATION BOARD AND RN1723 EVALUATION BOARD BILL OF MATERIALS (BOM)

Reference	Value	Description	Vendor	Vendor P/N
C1	100 nF	Cap ceramic, -20% / 80%, 16V, Y5V, 0603	Yageo	CC0603ZRY5V7BB104
C2, C3, C11	10 μ F	Cap ceramic, 20%, 6.3V, X5R, 0603	TDK Corporation	C1608X5R0J106M
C4, C5, C6	100 nF	Cap ceramic, -20%, 80%, 16V, Y5V, 0402	Yageo	CC0402ZRY5V7BB104
D1	Red	Clear, Red LED, 10 mA, 1.8V, 638 nm, 130 degrees, 1206	Lite-On Inc.	LTST-C150CKT
D2	Yellow	Clear, Yellow LED, 10 mA, 2.1V, 588 nm, 130 degrees, 1206	Lite-On Inc.	LTST-C150YKT
D3	Green	Clear, Green LED, 10 mA, 2.1V, 569 nm, 130 degrees, 1206	Lite-On Inc.	LTST-C150GKT
D4	Blue	Clear, Blue LED, 20 mA, 3.3V, 470 nm, 130 degrees, 1206	Lite-On Inc.	LTST-C150TBKT
D5, D6	PMEG2005CT,215	Dual Schottky diode, 1A, 20V, SOD-123F	NXP Semiconductor	PMEG2005CT,215
J6	USB mini-B	CONN USB RCPT MINI B 5PS R/A SMD	JAE	DX2R005HN2E700
L1	1 μ H	INDUCTOR 1.0UH 30% SMD	Taiyo Yuden	NR3015T1R0N
M1	—	RN171 Module	Microchip Technology Inc.	RN-171
Q1, Q2	DMN2050L	N MOSFET 5.9A, 20V, 29 mOhm, SOT23-3	Diodec Inc.	DMN2050L-7
R1, R2, R8, R17, R18	220k	Res, 5%, 0.1W, 0402	Panasonic - ECG	ERJ-2GEJ224X
R4, R6, R7, R9, R10, R12, R13, R14, R16, R19	100k	Res, 5%, 0.1W, 0402	Panasonic - ECG	ERJ-2GEJ104X
R5, R11, R15, R20	220R	Res, 5%, 0.1W, 0402	Panasonic - ECG	ERJ-2GEJ221X
R21, R22, R23, R24	3k3	Res, 5%, 0.1W, 0402	Panasonic - ECG	ERJ-2GEJ332X
S1, S2	Push button	SWITCH TACTILE SPST-NO 0.05A 32V	C&K Components	KSR211J
U1	TC1262-3.3V	Linear Voltage Regulator	Microchip Technology Inc.	TC1262-3.3VDBTR
U2	FT232RQ	IC USB FS SERIAL UART 32-QFN	FTDI	FT232RQ-REEL

Schematics, Bill of Materials, and Dimensions

A.4 PHYSICAL DIMENSIONS

FIGURE A-16: RN131 EVALUATION BOARD PHYSICAL DIMENSIONS

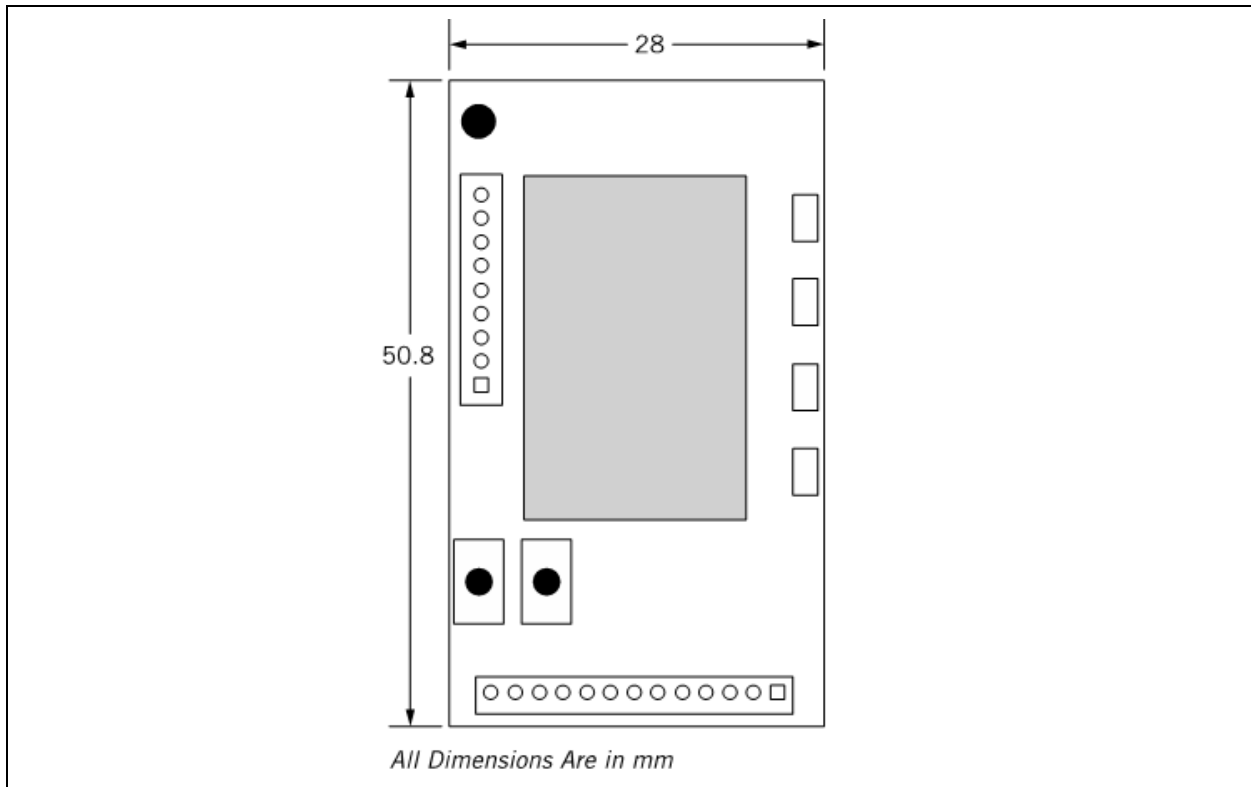
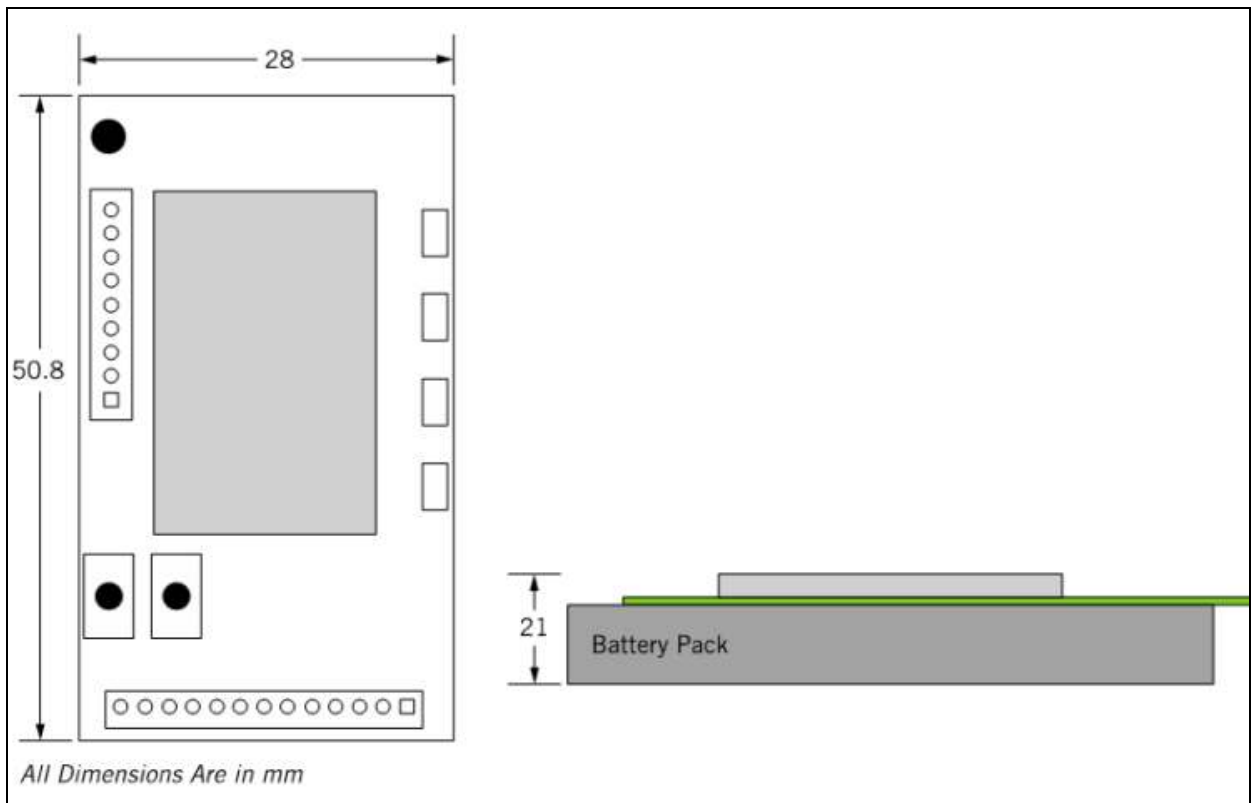

FIGURE A-17: RN171 EVALUATION BOARD AND RN1723 EVALUATION BOARD PHYSICAL DIMENSIONS





MICROCHIP

Worldwide Sales and Service

AMERICAS

Corporate Office
2355 West Chandler Blvd.
Chandler, AZ 85224-6199
Tel: 480-792-7200
Fax: 480-792-7277
Technical Support:
<http://www.microchip.com/support>
Web Address:
www.microchip.com

Atlanta
Duluth, GA
Tel: 678-957-9614
Fax: 678-957-1455

Austin, TX
Tel: 512-257-3370

Boston
Westborough, MA
Tel: 774-760-0087
Fax: 774-760-0088

Chicago
Itasca, IL
Tel: 630-285-0071
Fax: 630-285-0075

Cleveland
Independence, OH
Tel: 216-447-0464
Fax: 216-447-0643

Dallas
Addison, TX
Tel: 972-818-7423
Fax: 972-818-2924

Detroit
Novi, MI
Tel: 248-848-4000

Houston, TX
Tel: 281-894-5983

Indianapolis
Noblesville, IN
Tel: 317-773-8323
Fax: 317-773-5453

Los Angeles
Mission Viejo, CA
Tel: 949-462-9523
Fax: 949-462-9608

New York, NY
Tel: 631-435-6000

San Jose, CA
Tel: 408-735-9110

Canada - Toronto
Tel: 905-673-0699
Fax: 905-673-6509

ASIA/PACIFIC

Asia Pacific Office
Suites 3707-14, 37th Floor
Tower 6, The Gateway
Harbour City, Kowloon
Hong Kong
Tel: 852-2943-5100
Fax: 852-2401-3431

Australia - Sydney
Tel: 61-2-9868-6733
Fax: 61-2-9868-6755

China - Beijing
Tel: 86-10-8569-7000
Fax: 86-10-8528-2104

China - Chengdu
Tel: 86-28-8665-5511
Fax: 86-28-8665-7889

China - Chongqing
Tel: 86-23-8980-9588
Fax: 86-23-8980-9500

China - Dongguan
Tel: 86-769-8702-9880

China - Hangzhou
Tel: 86-571-8792-8115
Fax: 86-571-8792-8116

China - Hong Kong SAR
Tel: 852-2943-5100
Fax: 852-2401-3431

China - Nanjing
Tel: 86-25-8473-2460
Fax: 86-25-8473-2470

China - Qingdao
Tel: 86-532-8502-7355
Fax: 86-532-8502-7205

China - Shanghai
Tel: 86-21-5407-5533
Fax: 86-21-5407-5066

China - Shenyang
Tel: 86-24-2334-2829
Fax: 86-24-2334-2393

China - Shenzhen
Tel: 86-755-8864-2200
Fax: 86-755-8203-1760

China - Wuhan
Tel: 86-27-5980-5300
Fax: 86-27-5980-5118

China - Xian
Tel: 86-29-8833-7252
Fax: 86-29-8833-7256

ASIA/PACIFIC

China - Xiamen
Tel: 86-592-2388138
Fax: 86-592-2388130

China - Zhuhai
Tel: 86-756-3210040
Fax: 86-756-3210049

India - Bangalore
Tel: 91-80-3090-4444
Fax: 91-80-3090-4123

India - New Delhi
Tel: 91-11-4160-8631
Fax: 91-11-4160-8632

India - Pune
Tel: 91-20-3019-1500

Japan - Osaka
Tel: 81-6-6152-7160
Fax: 81-6-6152-9310

Japan - Tokyo
Tel: 81-3-6880-3770
Fax: 81-3-6880-3771

Korea - Daegu
Tel: 82-53-744-4301
Fax: 82-53-744-4302

Korea - Seoul
Tel: 82-2-554-7200
Fax: 82-2-558-5932 or
82-2-558-5934

Malaysia - Kuala Lumpur
Tel: 60-3-6201-9857
Fax: 60-3-6201-9859

Malaysia - Penang
Tel: 60-4-227-8870
Fax: 60-4-227-4068

Philippines - Manila
Tel: 63-2-634-9065
Fax: 63-2-634-9069

Singapore
Tel: 65-6334-8870
Fax: 65-6334-8850

Taiwan - Hsin Chu
Tel: 886-3-5778-366
Fax: 886-3-5770-955

Taiwan - Kaohsiung
Tel: 886-7-213-7828

Taiwan - Taipei
Tel: 886-2-2508-8600
Fax: 886-2-2508-0102

Thailand - Bangkok
Tel: 66-2-694-1351
Fax: 66-2-694-1350

EUROPE

Austria - Wels
Tel: 43-7242-2244-39
Fax: 43-7242-2244-393

Denmark - Copenhagen
Tel: 45-4450-2828
Fax: 45-4485-2829

France - Paris
Tel: 33-1-69-53-63-20
Fax: 33-1-69-30-90-79

Germany - Dusseldorf
Tel: 49-2129-3766400

Germany - Munich
Tel: 49-89-627-144-0
Fax: 49-89-627-144-44

Germany - Pforzheim
Tel: 49-7231-424750

Italy - Milan
Tel: 39-0331-742611
Fax: 39-0331-466781

Italy - Venice
Tel: 39-049-7625286

Netherlands - Drunen
Tel: 31-416-690399
Fax: 31-416-690340

Poland - Warsaw
Tel: 48-22-3325737

Spain - Madrid
Tel: 34-91-708-08-90
Fax: 34-91-708-08-91

Sweden - Stockholm
Tel: 46-8-5090-4654

UK - Wokingham
Tel: 44-118-921-5800
Fax: 44-118-921-5820

01/27/15