



1747.5 MHz Ceramic Band Pass Filter



ANATECH ELECTRONICS INC
RF & Microwave Filters & Products

Part Number: AM1747B1664

Electrical Specifications

Center Frequency: 1747.5 MHz
Bandwidth: $F_0 \pm 37.5$ MHz
Insertion Loss: 3.5 dB Max
Ripple in BW: 2.0 dB Max
Return Loss: 15.0 dB Min
Attenuation: >15 dB @ DC~1690 MHz
>15 dB @ 1805~1880 MHz
>50 dB @ 1880~2200 MHz
Input Power: 5.0 W Max

Mechanical

Mounting Method: SMT **Dimensions:**
26 x 14 x 4.65 mm

Environmental

Operating Temperature: -40 to +85° C
Storage Temperature: -55 to +95 C

Outline Drawing:

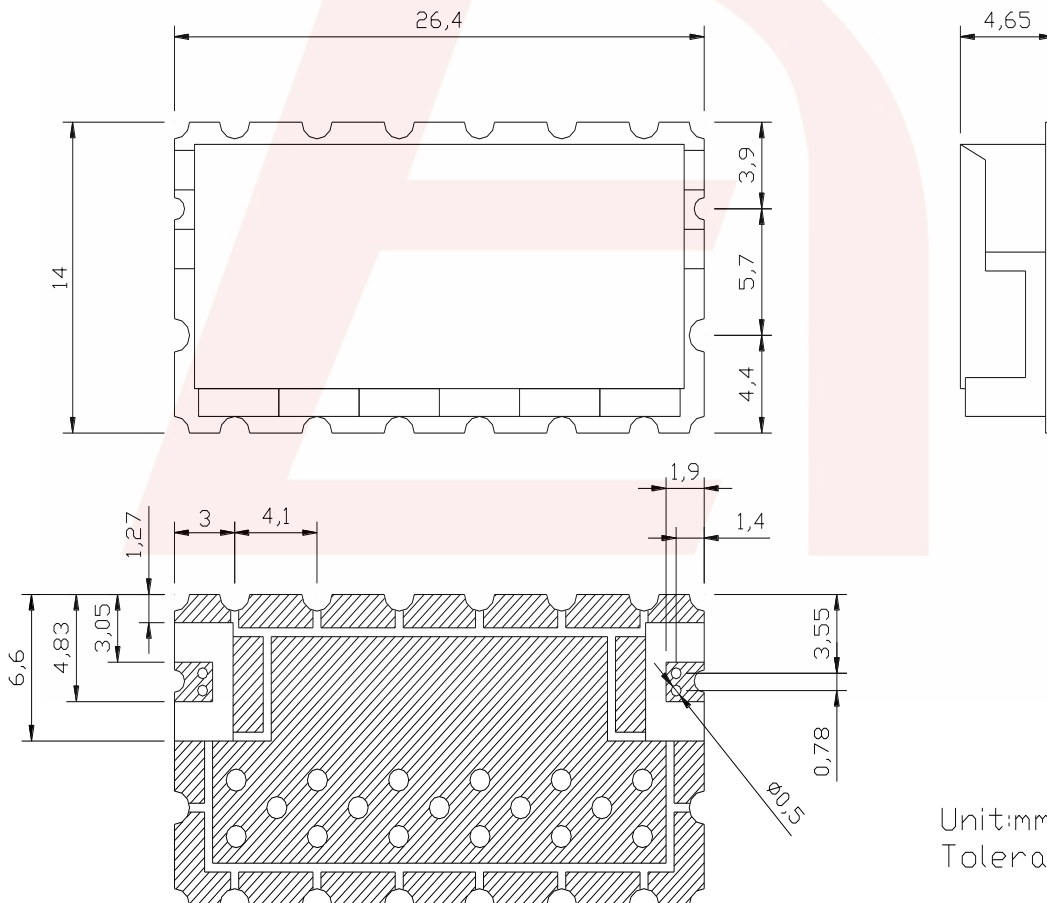

Unit:mm
Tolerance:±0.3



1747.5 MHz Ceramic Band Pass Filter



ANATECH ELECTRONICS INC
RF & Microwave Filters & Products

Part Number: AM1747B1664

PCB Layout:

