

Single-phase energy metering evaluation board with tamper monitoring, CT and shunt current sensor based on the STPM33

Data brief

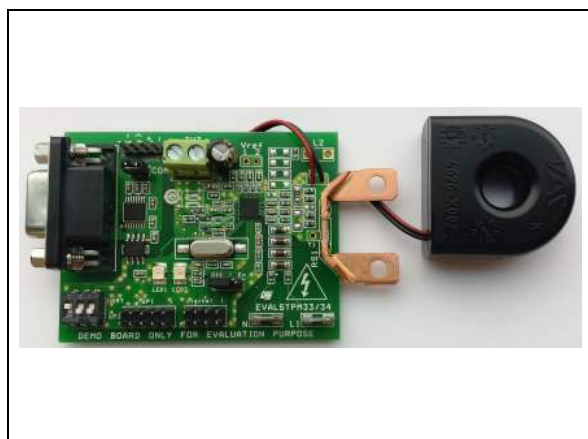

Description

The STPM33 energy metering evaluation board is a class 0.2, single-phase meter which includes tamper monitoring, CT and shunt current sensors for power line systems with $V_{nom} = 140$ to $300 V_{(RMS)}$, $I_{nom} / I_{max} = 5/100 A_{(RMS)}$, $f_{lin} = 50/60 Hz \pm 10\%$ and $T_{amb} = -40$ to $+85 ^\circ C$.

Measured active/reactive power can be output from two programmable LEDs on the board.

The board can be interfaced with a PC running evaluation software through an isolated RS232 port, or through the STEVAL-IPE023V1 USB isolated interface tool for configuration and data reading.

The board also has SPI/UART pins available to interface a microcontroller for application development.

Features

- 0.2% accuracy single-phase meter with tamper monitoring
- $V_{nom(RMS)} = 140$ to $300 V$, $I_{nom}/I_{max(RMS)} = 5/100 A$, $f_{lin} = 50/60 Hz \pm 10\%$
- Tamper detection through neutral current monitoring
- Connector for USB isolated hardware programmer tool STEVAL-IPE023V1 and PC GUI
- RS232 and UART isolated connectors to PC GUI
- SPI/UART switch for device peripheral selection
- 2 programmable LEDs on board
- Digital expansion to external system-on-chip or MCU
- 3.3 V power supply: external or through STEVAL-IPE023V1 isolated USB board
- IEC61000 standard compliant
- RoHS compliant

1 Schematic diagrams

Figure 1. RS232/UART circuit schematic

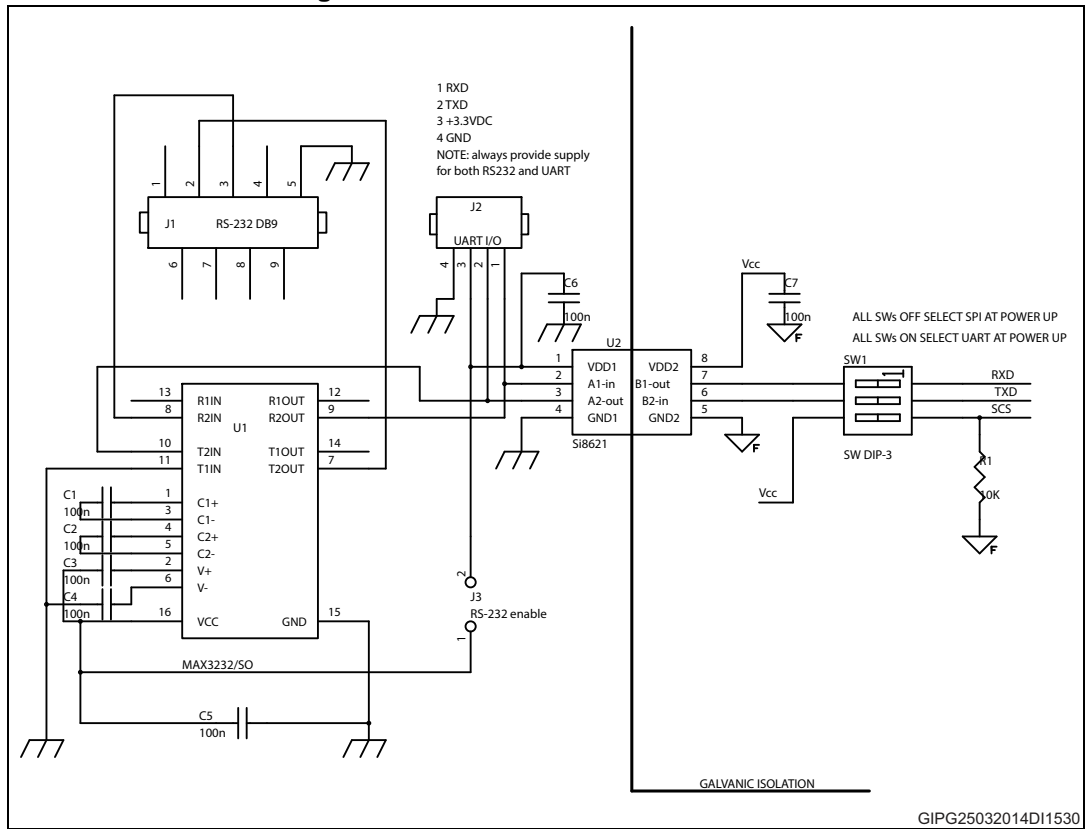
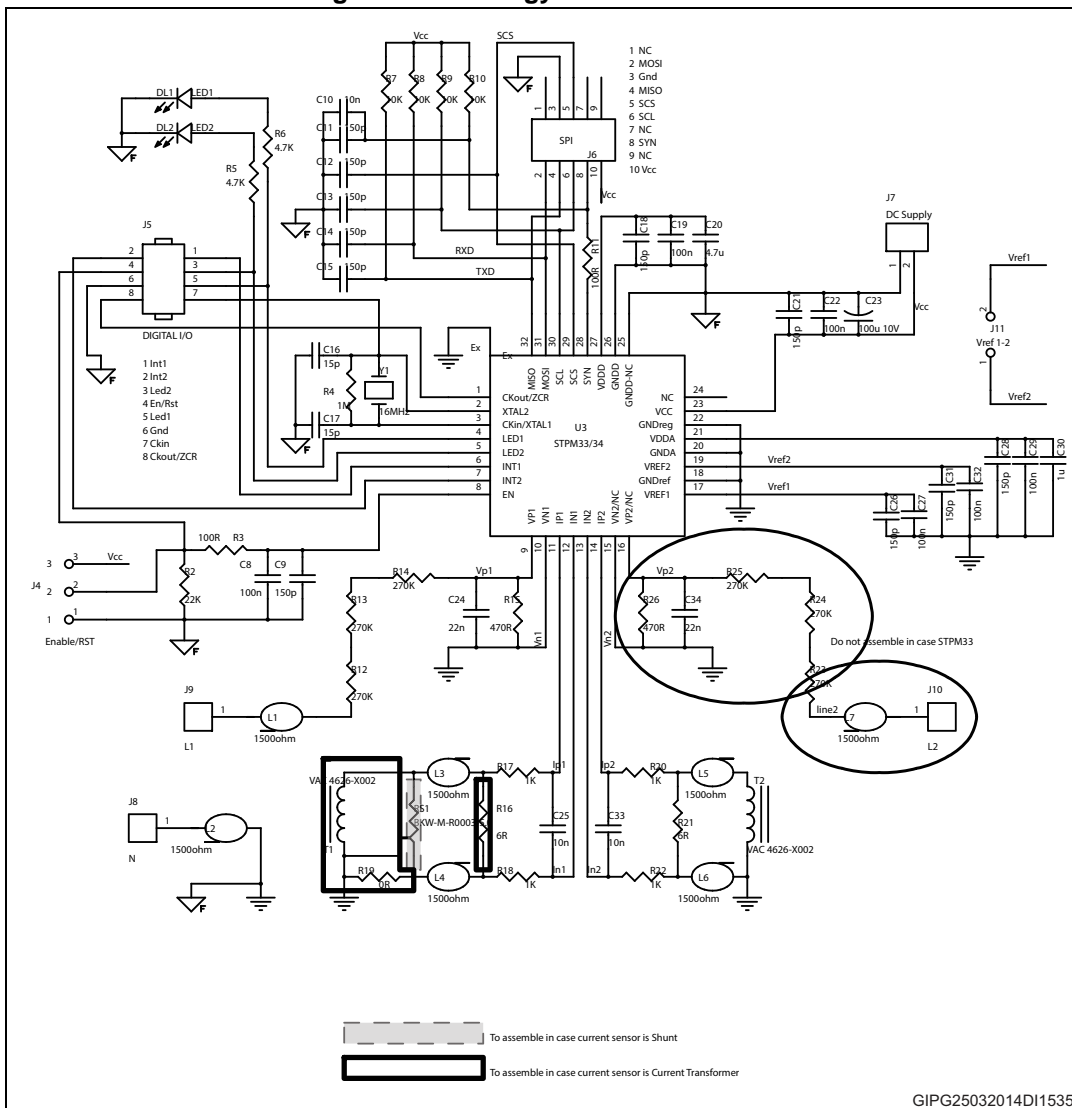

Figure 2. Metrology circuit schematic



GIPG25032014DI1535

2 Revision history

Table 1. Document revision history

| Date | Revision | Changes |
|-------------|----------|------------------|
| 31-Mar-2014 | 1 | Initial release. |

Please Read Carefully:

Information in this document is provided solely in connection with ST products. STMicroelectronics NV and its subsidiaries ("ST") reserve the right to make changes, corrections, modifications or improvements, to this document, and the products and services described herein at any time, without notice.

All ST products are sold pursuant to ST's terms and conditions of sale.

Purchasers are solely responsible for the choice, selection and use of the ST products and services described herein, and ST assumes no liability whatsoever relating to the choice, selection or use of the ST products and services described herein.

No license, express or implied, by estoppel or otherwise, to any intellectual property rights is granted under this document. If any part of this document refers to any third party products or services it shall not be deemed a license grant by ST for the use of such third party products or services, or any intellectual property contained therein or considered as a warranty covering the use in any manner whatsoever of such third party products or services or any intellectual property contained therein.

UNLESS OTHERWISE SET FORTH IN ST'S TERMS AND CONDITIONS OF SALE ST DISCLAIMS ANY EXPRESS OR IMPLIED WARRANTY WITH RESPECT TO THE USE AND/OR SALE OF ST PRODUCTS INCLUDING WITHOUT LIMITATION IMPLIED WARRANTIES OF MERCHANTABILITY, FITNESS FOR A PARTICULAR PURPOSE (AND THEIR EQUIVALENTS UNDER THE LAWS OF ANY JURISDICTION), OR INFRINGEMENT OF ANY PATENT, COPYRIGHT OR OTHER INTELLECTUAL PROPERTY RIGHT.

ST PRODUCTS ARE NOT DESIGNED OR AUTHORIZED FOR USE IN: (A) SAFETY CRITICAL APPLICATIONS SUCH AS LIFE SUPPORTING, ACTIVE IMPLANTED DEVICES OR SYSTEMS WITH PRODUCT FUNCTIONAL SAFETY REQUIREMENTS; (B) AERONAUTIC APPLICATIONS; (C) AUTOMOTIVE APPLICATIONS OR ENVIRONMENTS, AND/OR (D) AEROSPACE APPLICATIONS OR ENVIRONMENTS. WHERE ST PRODUCTS ARE NOT DESIGNED FOR SUCH USE, THE PURCHASER SHALL USE PRODUCTS AT PURCHASER'S SOLE RISK, EVEN IF ST HAS BEEN INFORMED IN WRITING OF SUCH USAGE, UNLESS A PRODUCT IS EXPRESSLY DESIGNATED BY ST AS BEING INTENDED FOR "AUTOMOTIVE, AUTOMOTIVE SAFETY OR MEDICAL" INDUSTRY DOMAINS ACCORDING TO ST PRODUCT DESIGN SPECIFICATIONS. PRODUCTS FORMALLY ESCC, QML OR JAN QUALIFIED ARE DEEMED SUITABLE FOR USE IN AEROSPACE BY THE CORRESPONDING GOVERNMENTAL AGENCY.

Resale of ST products with provisions different from the statements and/or technical features set forth in this document shall immediately void any warranty granted by ST for the ST product or service described herein and shall not create or extend in any manner whatsoever, any liability of ST.

ST and the ST logo are trademarks or registered trademarks of ST in various countries.

Information in this document supersedes and replaces all information previously supplied.

The ST logo is a registered trademark of STMicroelectronics. All other names are the property of their respective owners.

© 2014 STMicroelectronics - All rights reserved

STMicroelectronics group of companies

Australia - Belgium - Brazil - Canada - China - Czech Republic - Finland - France - Germany - Hong Kong - India - Israel - Italy - Japan - Malaysia - Malta - Morocco - Philippines - Singapore - Spain - Sweden - Switzerland - United Kingdom - United States of America

www.st.com

