

Evaluation Board for **AD5666**, Quad, 16-Bit, Buffered Voltage-Output DAC

FEATURES

- Full featured evaluation board for the **AD5666**
- On-board reference
- Various link options
- PC control in conjunction with Analog Devices, Inc., system demonstration platform (SDP)
- PC software for control of DAC

EVALUATION KIT CONTENTS

- EVAL-AD5666SDZ** evaluation board
- AD5666** device
- CD that includes
 - Self-installing software that allows users to control the board and exercise all functions of the device
 - Electronic version of the **AD5666** data sheet

ADDITIONAL EQUIPMENT NEEDED

- EVAL-SDP-CS1Z** system demonstration platform
- PC with Windows XP, Windows Vista (64-bit/32-bit), or Windows 7 (64-bit/32-bit) operating system

GENERAL DESCRIPTION

The Analog Devices, Inc., **AD5666** evaluation board (**EVAL-AD5666SDZ**) is designed to help customers quickly prototype new **AD5666** circuits and reduce design time. The **AD5666** operates from a single supply. The board populates the **AD5666BRUZ-2**, which has a 2.5 V, 5 ppm/°C reference, giving a full-scale output of 5 V. Additionally, the board populates 2.5 V and 5 V external references, giving a full-scale output of 2.5 V and 5 V, respectively.

Full data on the **AD5666** can be found in the **AD5666** data sheet, which should be consulted in conjunction with this document when using the evaluation board.

The evaluation board interfaces to the PC via the SDP board. Software is included in the evaluation board kit that allows you to easily program the **AD5666**.

PHOTOGRAPH OF THE EVALUATION BOARD

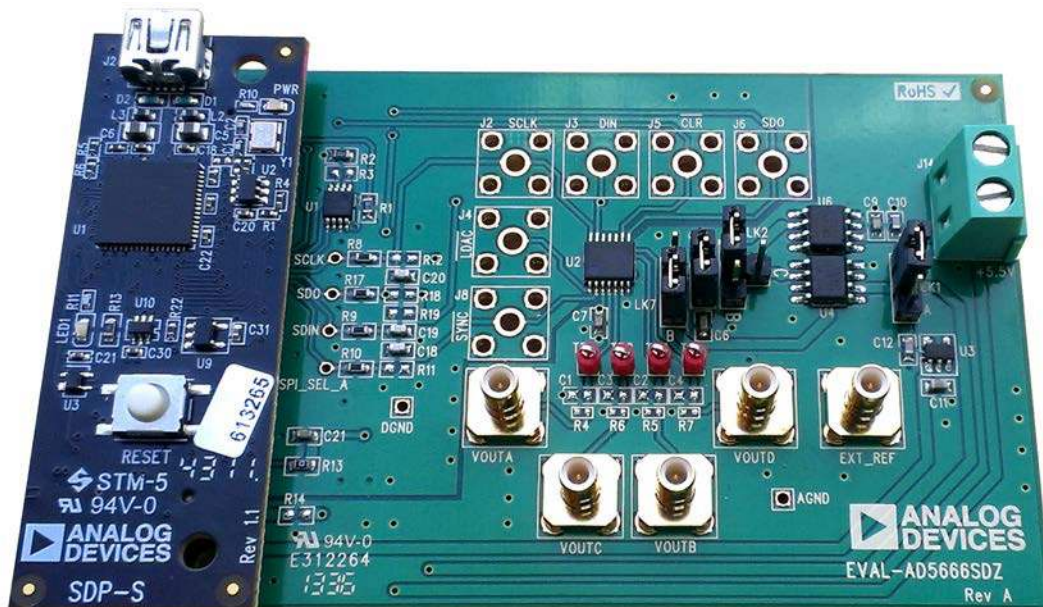

Figure 1.

TABLE OF CONTENTS

Features	1	Link Options	3
Evaluation Kit Contents.....	1	Evaluation Board Software.....	4
Additional Equipment Needed	1	Installing the Software	4
General Description	1	Running the Software	4
Photograph of the Evaluation Board.....	1	Operating the Software.....	5
Revision History	2	Evaluation Board Schematics and Artwork	7
Evaluation Board Hardware.....	3	Bill of Materials.....	10
Power Supplies	3		

REVISION HISTORY

11/13—Revision 0: Initial Version

EVALUATION BOARD HARDWARE

POWER SUPPLIES

The [AD5666](#) evaluation board can be powered either from the on-board regulator of 3.3 V or externally by the J14-1 and J14-2 connectors, as described in Table 1.

Only an AGND connector is provided on the board. The AGND and DGND planes are connected at one point under the [AD5666](#) device. It is recommended not to connect AGND and DGND elsewhere in the system to avoid ground loop problems.

The supply is decoupled to ground with 10 μ F tantalum and 0.1 μ F ceramic capacitors.

Table 1. Power Supply Connectors

Connector No.	Name	Voltage
J14-1	+5.5V	From 2.7 V to 5.5 V
J14-2	GND	AGND

LINK OPTIONS

Before using the evaluation board, the link options must be set for the desired operating mode (see Table 2 for more information). By default, the evaluation board is set up to be controlled by a PC via the USB port and SDP board.

Table 2. Link Functions

Link No.	Option	Default Position
LK1	This link selects the main board voltage source. Position A selects the regulated voltage from the USB voltage source, 3.3 V. Position B selects the external supply voltage provided by the J14 connector.	B
LK2	This link selects the DAC voltage reference. Position A selects the REF195 external reference. This reference is operational only if the board is powered externally with a voltage higher than 5.1 V. Position B selects an off-board reference. Position C selects the REF192 external reference.	C
LK7	This link selects the supply voltage for the AD5666 . Position A selects the source selected by LK1. Position B selects the source selected by LK2.	B
LK8	This link adds an external capacitor on the AD5666 V_{REF} voltage. Inserted selects the capacitor to be connected. Disconnected selects the capacitor to be disconnected.	Inserted

EVALUATION BOARD SOFTWARE

INSTALLING THE SOFTWARE

The EVAL-AD5666SDZ kit includes self-installing software on a CD. The software is compatible with Windows® XP, Windows Vista (64-bit/32-bit), and Windows 7 (64-bit/32-bit).

Install the software before connecting the SDP board to the USB port of the PC. This ensures that the SDP board is recognized when it is connected to the PC.

1. Start the Windows operating system and insert the CD.
2. The installation software should open automatically. If it does not, run the **setup.exe** file from the CD.
3. After installation is completed, power up the evaluation board as described in the Power Supplies section.
4. Plug the EVAL-AD5666SDZ into the SDP board and the SDP board into the PC using the USB cable included in the evaluation board kit.
5. When the software detects the evaluation board, proceed through any dialog boxes that appear to finalize the installation.

RUNNING THE SOFTWARE

To run the program, do the following:

1. Click **Start > All Programs > Analog Devices > AD5666 > AD5666 Evaluation Software**. (To uninstall the program, click **Start > Control Panel > Add or Remove Programs > AD5666 Evaluation Software**.)
2. If the SDP board is not connected to the USB port when the software is launched, a connectivity error is displayed (see Figure 2). If a connectivity error is displayed, connect the evaluation board to the USB port of the PC and wait a few seconds, and then click **Rescan** and follow the instructions.

3. If the SDP board is not connected to the evaluation board, a message box appears as shown in Figure 3. Check the connection between the SDP and EVAL-AD5666SDZ boards and then run the program again.

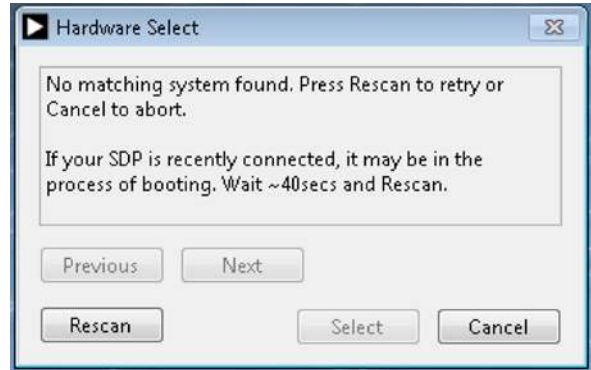

Figure 3. SDP Board to Evaluation Board Error Message

4. When the SDP board is connected, a wait window is displayed briefly (see Figure 4), and then the main window of the AD5666 evaluation software opens, as shown in Figure 5.

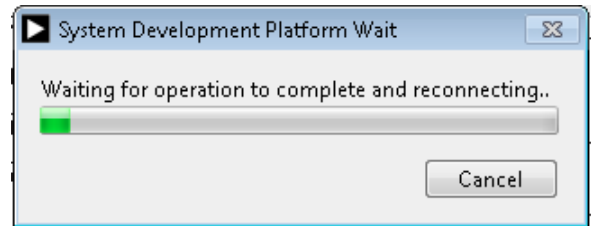

Figure 4. System Development Platform Wait Window

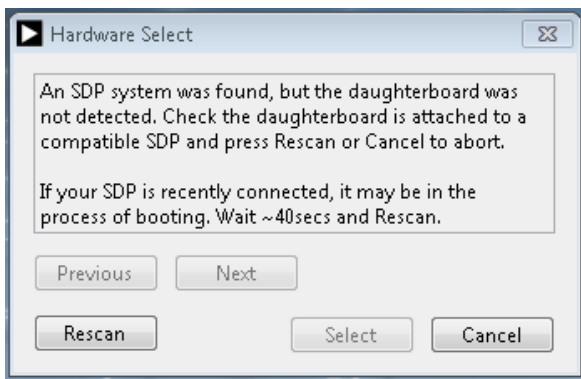

Figure 2. SDP Board to USB Port Connectivity Error Message

OPERATING THE SOFTWARE

To run the AD5666 GUI, click **Start > All Programs > Analog Devices > AD5666 > AD5666 Evaluation Software**.

The AD5666 main window opens, as shown in Figure 5.

The **DAC Controls** tab (see Figure 5) allows you to view the input register, DAC register, and output voltage (V_{OUTA} to V_{OUTD}). On the left side of the window, you can type a hexadecimal value into the **INPUT VALUE (Hex)** box to be written to the input and/or DAC registers as follows:

- Click **Write to Input Register** to write the value to the input register. This updates only the input register; the DAC register is not updated.
- Click **Update DAC Register from Input Register** to update the DAC register.
- Click **Write to DAC Channel** to simultaneously write to the input register and update the DAC register.

The **DAC Registers** tab (see Figure 6) allows you to access the clear code register, reset register, internal reference register, LDAC register, and power-down register. Therefore, this tab allows you to change the parameters of the device and how the device performs.

Hardware Pins

To set the LDAC and CLR pins to high or low, click the appropriate check box under the block diagram in the main window. This command is executed immediately.

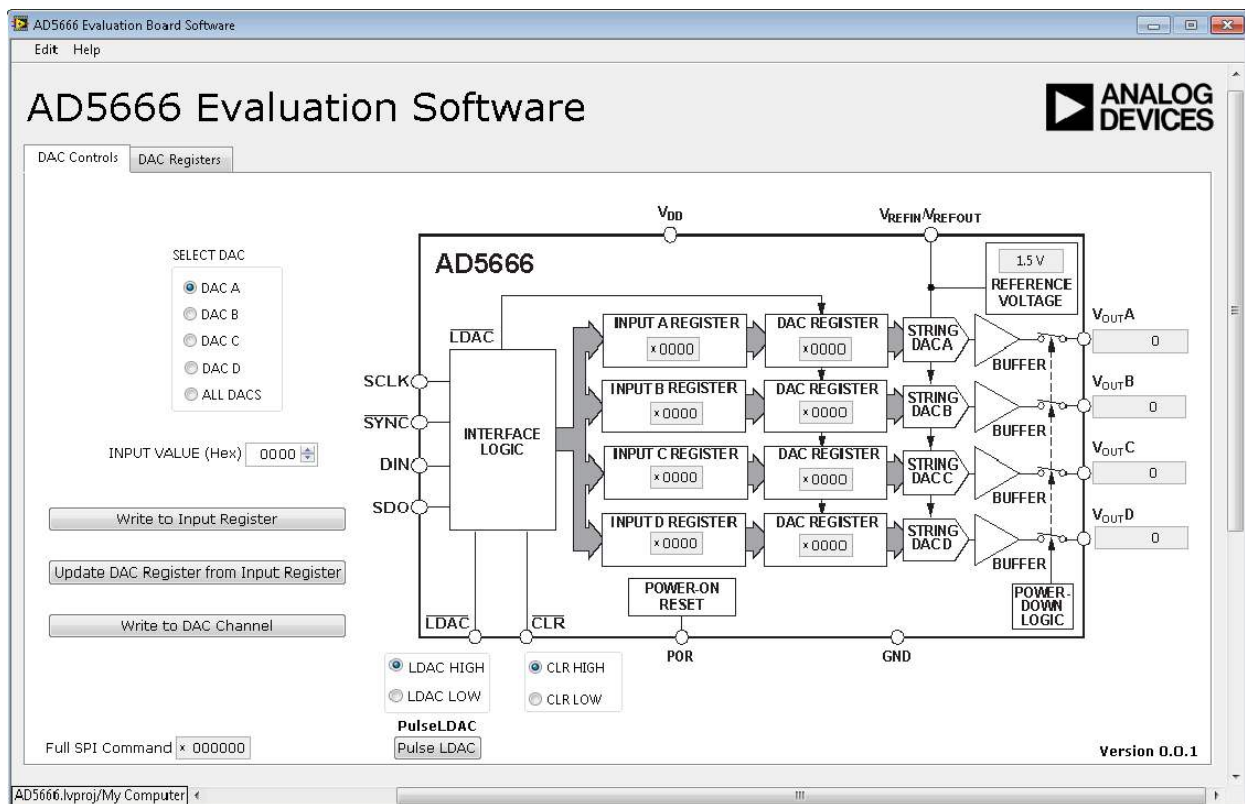

Figure 5. AD5666 Evaluation Board Main Window, DAC Controls Tab

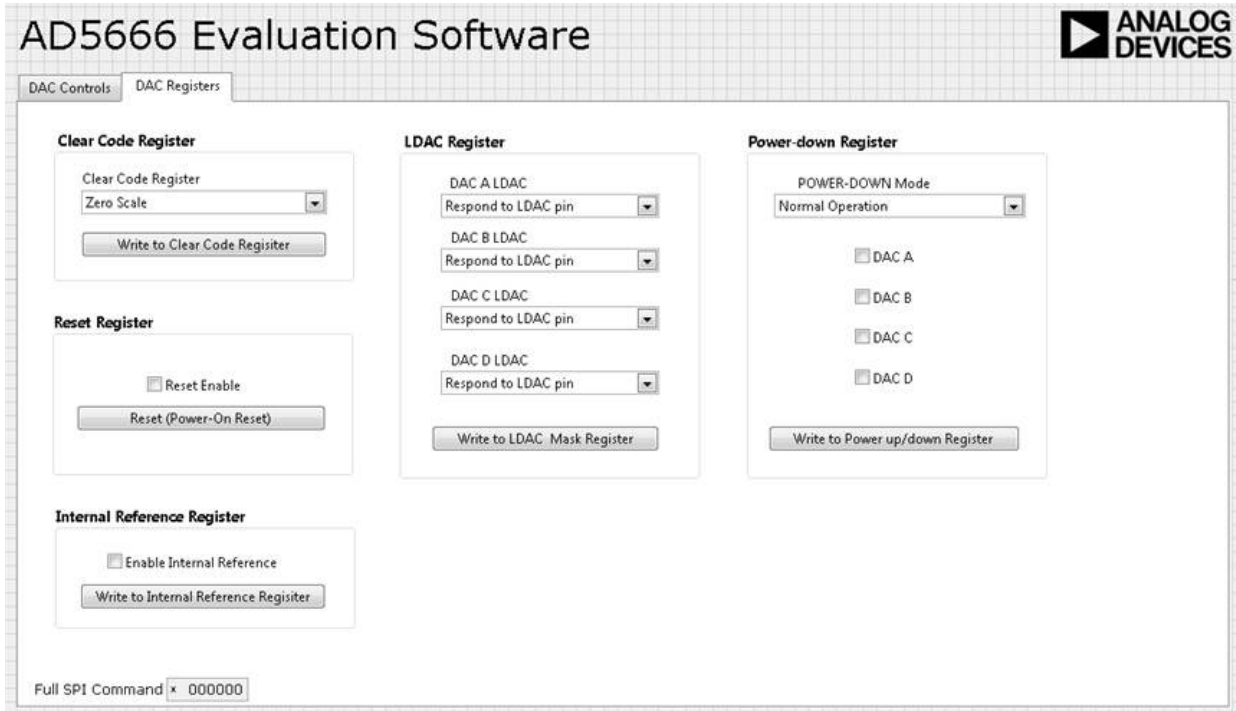

Figure 6. AD5666 Evaluation Board Main Window, DAC Registers Tab

EVALUATION BOARD SCHEMATICS AND ARTWORK

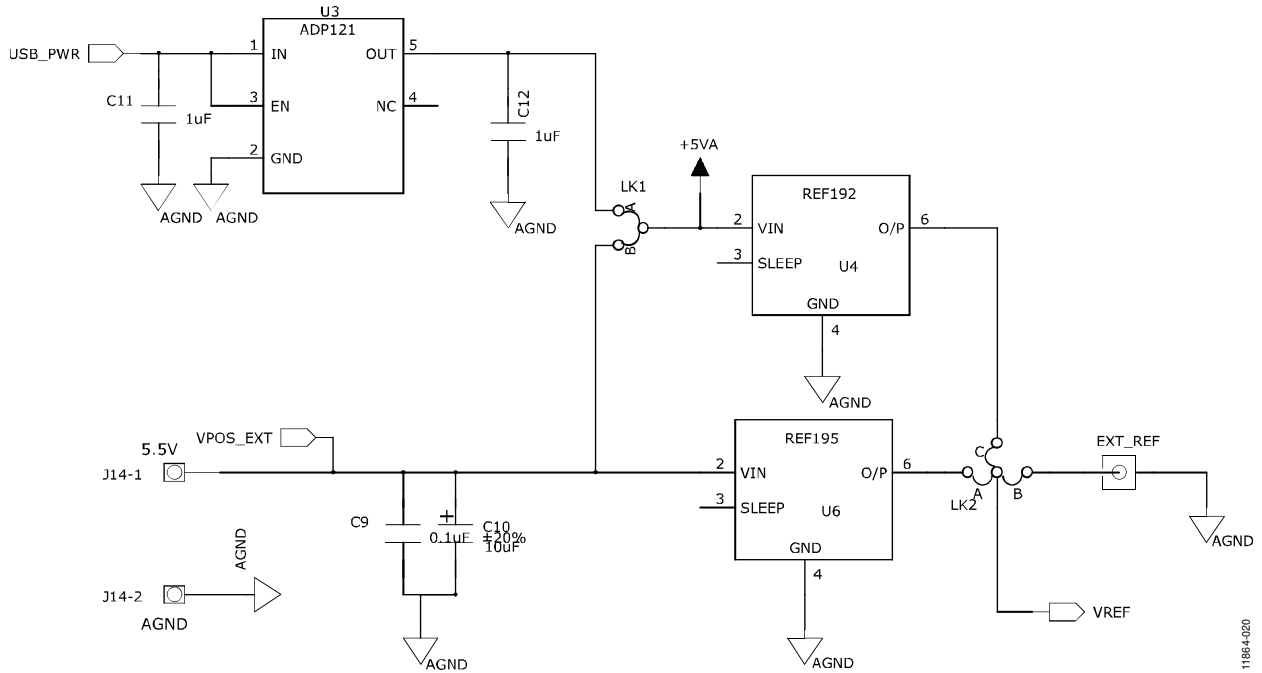

Figure 7. Schematic of Supply and References

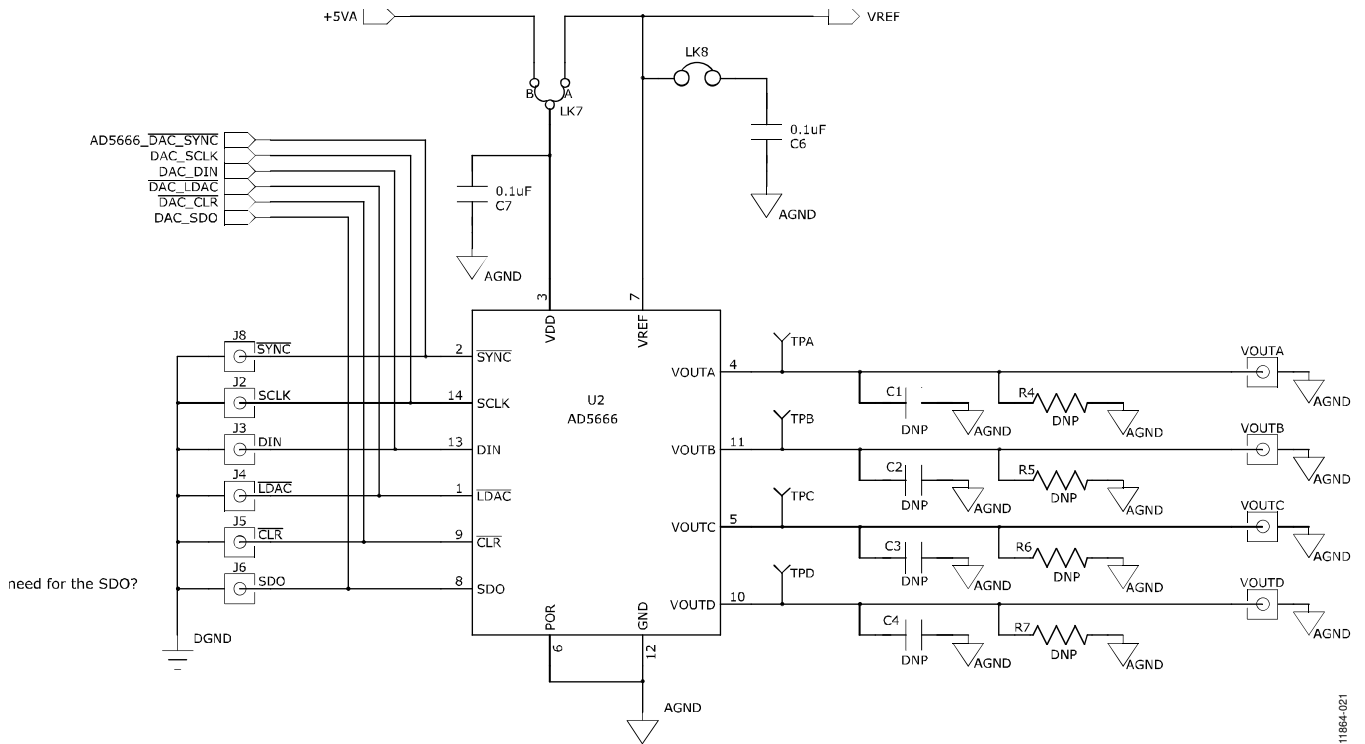

Figure 8. Schematic of AD5666 Evaluation Circuitry

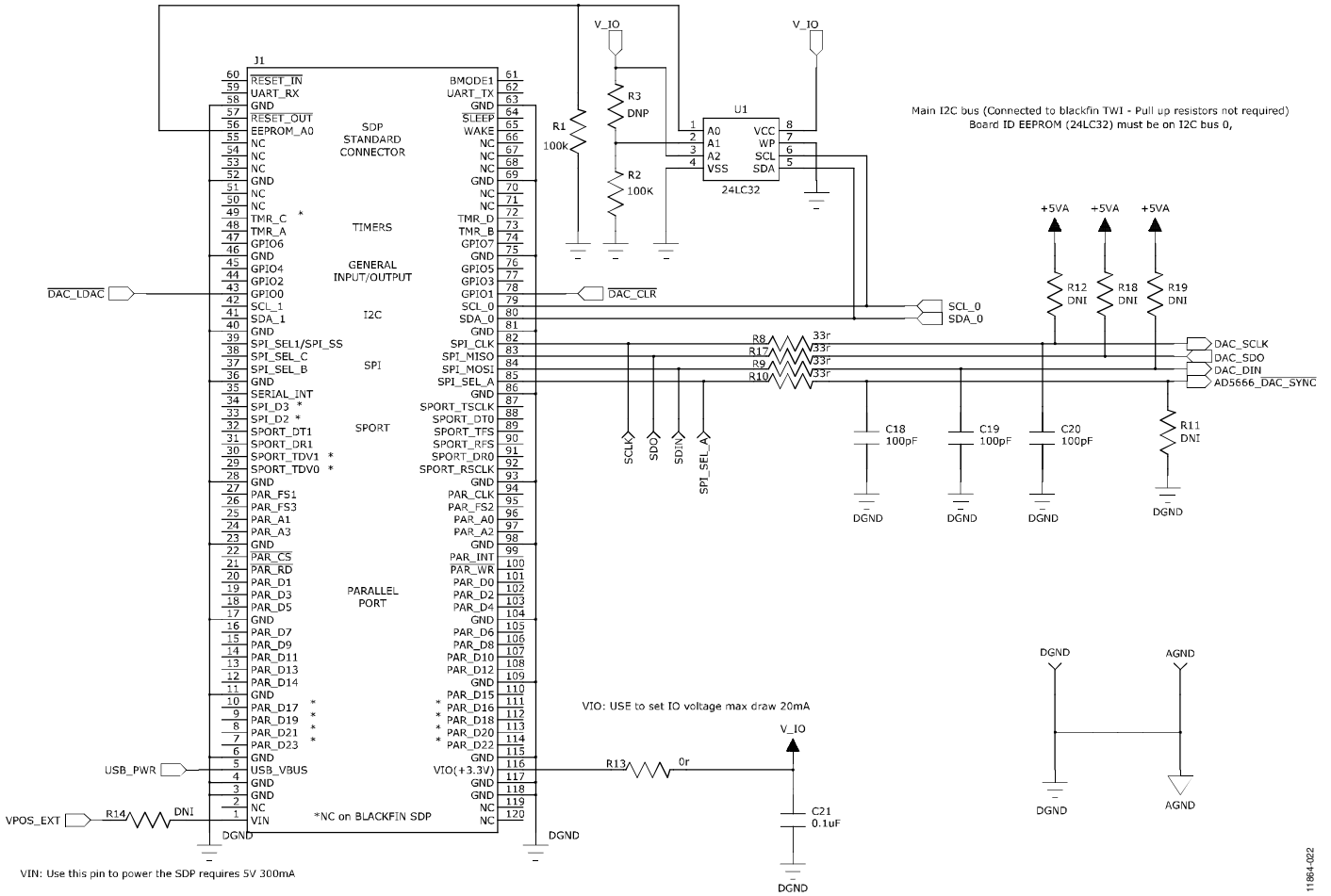
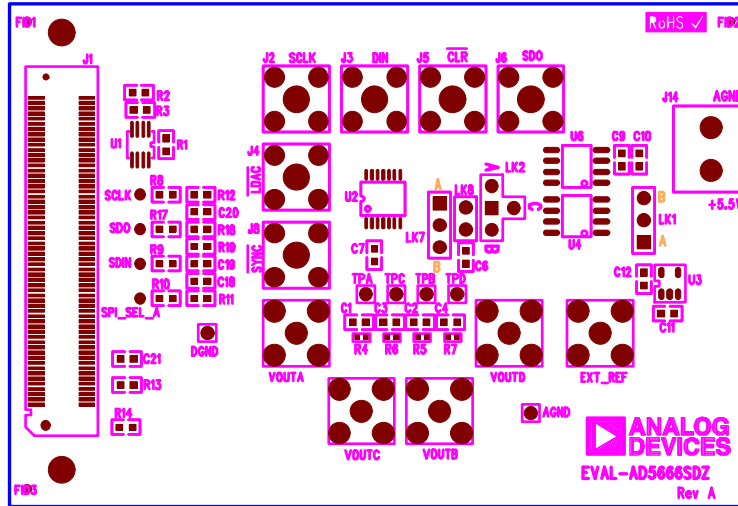
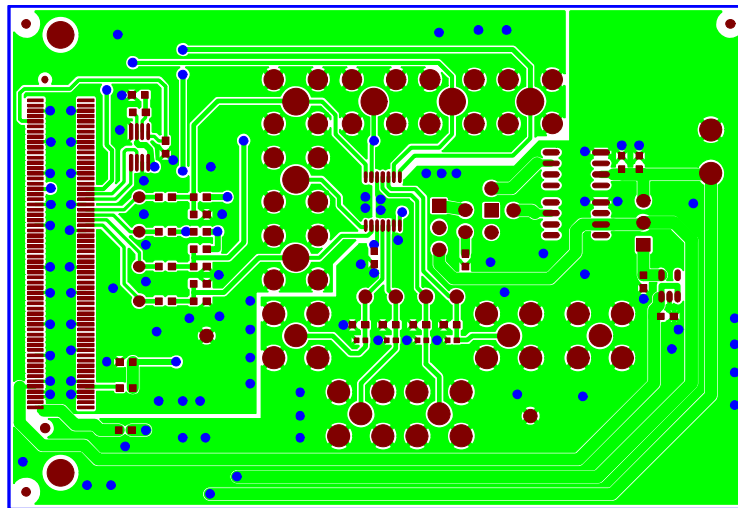

Figure 9. Schematic of SDP Connector

11864-02Z



11864-011



11864-009

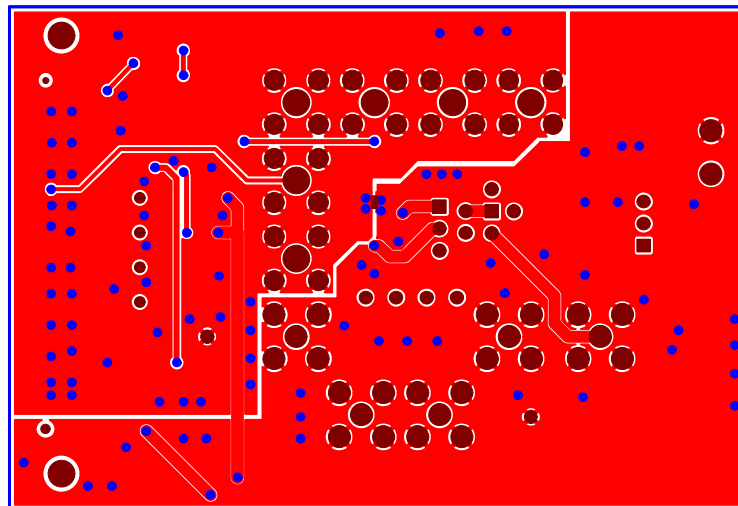

11864-010

BILL OF MATERIALS

Table 3. EVAL-AD5666SDZ Bill of Materials

Qty	Reference Designator	Description	Supplier/Part Number
3	C18, C19, C20	Capacitor, 0603, 100 V, 100 pF	Farnell 1740605
4	C6, C7, C9, C21	Capacitor, 0603, 25 V, 0.1 μ F	Farnell 1828899
2	C11, C12	Capacitor, 0603, 1 μ F, 16 V	Farnell 1658870
2	C9, C16	Capacitor, 0603, 10 μ F, 10 V	Farnell 1853538
4	R8, R9, R10, R17	Resistor, 0603, 33 Ω	Farnell 9331050
1	R13	Resistor, 0603, 0 Ω	Farnell 9331662
5	EXT_REF, VOUTA, VOUTB, VOUTC, VOUTD	SMB connector	Farnell 1206013
1	J1	120-way connector	Farnell 1324660
1	J14	2-pin terminal block	Farnell 151789
2	LK1, LK2	3-pin connector	Farnell 1022249 and Farnell 150411
1	LK7	3-pin connector	Farnell 1022248 and Farnell 150410
1	LK8	3-pin connector	Farnell 1022247 and Farnell 150411
4	TPA, TPB, TPC, TPD	Test point	Farnell 8731144
1	U1	32k I ² C serial EEPROM	Farnell 1331330
1	U2	Quad, 16-bit DAC	AD5666BRUZ-2
1	U3	3.3 V regulator	ADP121-AUJZ33R7
1	U4	2.5 V reference	REF192GSZ
1	U6	5 V reference	REF195ESZ
2	Screw1, Screw2	SDP screw	Farnell 7070597
2	Nut1, Nut2	SDP nut	Farnell 7061857

NOTES

NOTES

**ESD Caution**

ESD (electrostatic discharge) sensitive device. Charged devices and circuit boards can discharge without detection. Although this product features patented or proprietary protection circuitry, damage may occur on devices subjected to high energy ESD. Therefore, proper ESD precautions should be taken to avoid performance degradation or loss of functionality.

Legal Terms and Conditions

By using the evaluation board discussed herein (together with any tools, components documentation or support materials, the "Evaluation Board"), you are agreeing to be bound by the terms and conditions set forth below ("Agreement") unless you have purchased the Evaluation Board, in which case the Analog Devices Standard Terms and Conditions of Sale shall govern. Do not use the Evaluation Board until you have read and agreed to the Agreement. Your use of the Evaluation Board shall signify your acceptance of the Agreement. This Agreement is made by and between you ("Customer") and Analog Devices, Inc. ("ADI"), with its principal place of business at One Technology Way, Norwood, MA 02062, USA. Subject to the terms and conditions of the Agreement, ADI hereby grants to Customer a free, limited, personal, temporary, non-exclusive, non-sublicensable, non-transferable license to use the Evaluation Board FOR EVALUATION PURPOSES ONLY. Customer understands and agrees that the Evaluation Board is provided for the sole and exclusive purpose referenced above, and agrees not to use the Evaluation Board for any other purpose. Furthermore, the license granted is expressly made subject to the following additional limitations: Customer shall not (i) rent, lease, display, sell, transfer, assign, sublicense, or distribute the Evaluation Board; and (ii) permit any Third Party to access the Evaluation Board. As used herein, the term "Third Party" includes any entity other than ADI, Customer, their employees, affiliates and in-house consultants. The Evaluation Board is NOT sold to Customer; all rights not expressly granted herein, including ownership of the Evaluation Board, are reserved by ADI. CONFIDENTIALITY. This Agreement and the Evaluation Board shall all be considered the confidential and proprietary information of ADI. Customer may not disclose or transfer any portion of the Evaluation Board to any other party for any reason. Upon discontinuation of use of the Evaluation Board or termination of this Agreement, Customer agrees to promptly return the Evaluation Board to ADI. ADDITIONAL RESTRICTIONS. Customer may not disassemble, decompile or reverse engineer chips on the Evaluation Board. Customer shall inform ADI of any occurred damages or any modifications or alterations it makes to the Evaluation Board, including but not limited to soldering or any other activity that affects the material content of the Evaluation Board. Modifications to the Evaluation Board must comply with applicable law, including but not limited to the RoHS Directive. TERMINATION. ADI may terminate this Agreement at any time upon giving written notice to Customer. Customer agrees to return to ADI the Evaluation Board at that time. LIMITATION OF LIABILITY. THE EVALUATION BOARD PROVIDED HEREUNDER IS PROVIDED "AS IS" AND ADI MAKES NO WARRANTIES OR REPRESENTATIONS OF ANY KIND WITH RESPECT TO IT. ADI SPECIFICALLY DISCLAIMS ANY REPRESENTATIONS, ENDORSEMENTS, GUARANTEES, OR WARRANTIES, EXPRESS OR IMPLIED, RELATED TO THE EVALUATION BOARD INCLUDING, BUT NOT LIMITED TO, THE IMPLIED WARRANTY OF MERCHANTABILITY, TITLE, FITNESS FOR A PARTICULAR PURPOSE OR NON-INFRINGEMENT OF INTELLECTUAL PROPERTY RIGHTS. IN NO EVENT WILL ADI AND ITS LICENSORS BE LIABLE FOR ANY INCIDENTAL, SPECIAL, INDIRECT, OR CONSEQUENTIAL DAMAGES RESULTING FROM CUSTOMER'S POSSESSION OR USE OF THE EVALUATION BOARD, INCLUDING BUT NOT LIMITED TO LOST PROFITS, DELAY COSTS, LABOR COSTS OR LOSS OF GOODWILL. ADI'S TOTAL LIABILITY FROM ANY AND ALL CAUSES SHALL BE LIMITED TO THE AMOUNT OF ONE HUNDRED US DOLLARS (\$100.00). EXPORT. Customer agrees that it will not directly or indirectly export the Evaluation Board to another country, and that it will comply with all applicable United States federal laws and regulations relating to exports. GOVERNING LAW. This Agreement shall be governed by and construed in accordance with the substantive laws of the Commonwealth of Massachusetts (excluding conflict of law rules). Any legal action regarding this Agreement will be heard in the state or federal courts having jurisdiction in Suffolk County, Massachusetts, and Customer hereby submits to the personal jurisdiction and venue of such courts. The United Nations Convention on Contracts for the International Sale of Goods shall not apply to this Agreement and is expressly disclaimed.