

© 1968 BY AMP INCORPORATED. ALL RIGHTS RESERVED. AMP PRODUCTS COVERED BY PATENTS AND/OR PATENTS PENDING.

NUMBER 52007

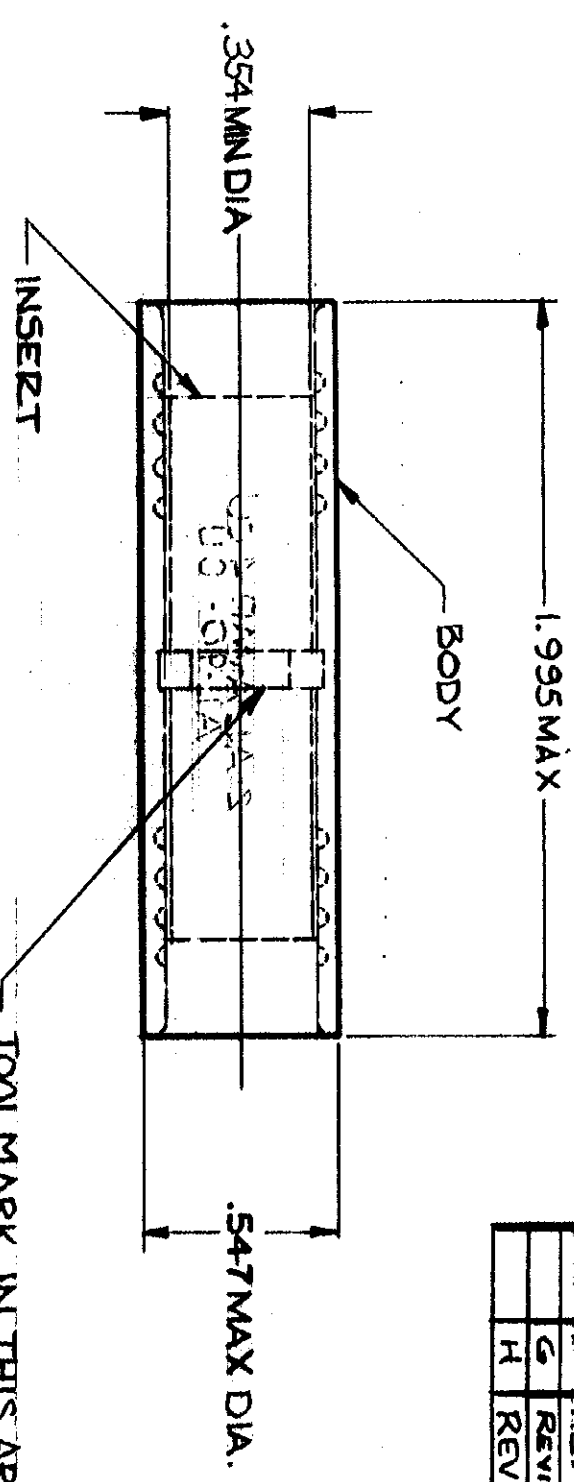
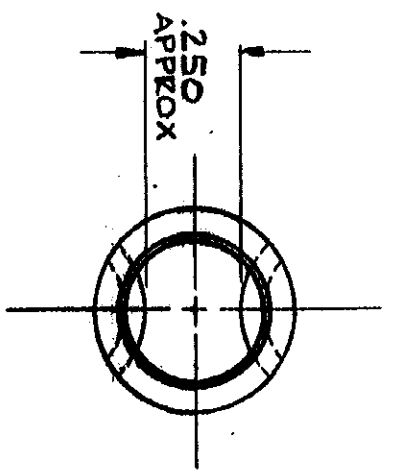

ZONE	LTR	REVISIONS	DESCRIPTION	DATE	APPROVED
0			NPS 68-0306 (REV 1) <i>gms</i>	9-10-68	<i>RHW</i>
A			REV TITLE PER ECN P-5545 <i>gms</i>	12-6-68	<i>RHW</i>
B			REV: .547 MAX DIA W/ .537 MAX DIA P-6002 <i>gms</i>	4-18-69	<i>RHW</i>
C			CHANGED .36970 .354 PER ECN P-6105 <i>gms</i>	9-16-69	<i>FCY</i>
D			REVISED PER ECN P-6263 <i>gms</i>	1-8-70	<i>FCY</i>
E			REMOVED ENGINEERING CONT. P-6288 <i>gms</i>	4-17-70	<i>FCY</i>
F			REVISED PER ECN F-578 <i>gms</i>	1-11-72	<i>gms</i>
G			REVISED PER G-2072 <i>gms</i>	3-21-87	<i>gms</i>
H			REV PER G-5318 <i>gms</i>	10/25/89	<i>WST</i>

QTY	DESCRIPTION	PART NO.	MATERIAL # FINISH
1	WIRE SPLICE	52007	BODY: COPPER (QQ-C-576) TIN PL (MIL-T-10727) INSERT: BRASS (MIL-C-50) TIN PL (MIL-T-10727).0003MIN EXT THK.

OTHERWISE SPECIFIED DIM. ARE IN INCHES. TOLERANCES ON: DECIMALS ±.000 ANGLES ± 5° MATERIAL SEE TABLE	
CONTRACT NO. B-3-68 DATE: 10-10-68 DESIGNED BY: <i>[Signature]</i> CHECKED BY: <i>[Signature]</i> APPROVED BY: <i>[Signature]</i> DATE: 10-10-68	AMP INCORPORATED HARRISBURG, PENNSYLVANIA
NAME: WIRE SPLICE - BUTT COPALUM-STRANDED/SOLID WIRE SIZE: #2AL-4CU	AMP INCORPORATED HARRISBURG, PENNSYLVANIA
SIZE: B CODE IDENT NO.: 00779 SCALE: 2:1	NUMBER: 52007 SHEET: 1 OF 1

AMP INFO
 LOC 5861
 FINISH SEE TABLE