



MAX3643 Evaluation Kit

General Description

The MAX3643 evaluation kit (EV kit) is an assembled demonstration board that provides optical evaluation of the MAX3643 155Mbps to 2.5Gbps burst-mode laser driver. The evaluation board allows connection with coaxial laser packages as well as BIDI packages.

EV Kit Contents

◆ MAX3643 EV Kit Board

Features

- ◆ Fully Assembled and Tested
- ◆ Adjustable Laser Bias Current
- ◆ Adjustable Laser Modulation Current
- ◆ Single +3.3V Power-Supply Operation

Ordering Information

PART	TYPE
MAX3643EVKIT+	EV Kit

+Denotes lead(Pb)-free and RoHS compliant.

Component List

DESIGNATION	QTY	DESCRIPTION
C1	1	1 μ F \pm 10% ceramic capacitor (0402) Murata GRM155R61A105KE15D
C2	1	1000pF \pm 10% ceramic capacitor (0402) Murata GRM155R71H102KA01D
C5, C10, C11, C13, C15	5	0.1 μ F \pm 10% ceramic capacitors (0402) Murata GRM155R61A104KA01D
C7	1	0.01 μ F \pm 10% ceramic capacitor (0603) TDK C1005X8R1E103K
C8	1	0.1 μ F \pm 10% ceramic capacitor (0603) Murata GRM188R71H104KA93D
C14	0	Not installed, ceramic capacitor (0603)
C16	1	10 μ F \pm 10% tantalum capacitor (B case) AVX TAJB106K010RNJ
C24	1	27pF \pm 5% ceramic capacitor (0402) Murata GRM1555C1H270JZ01D
C25, C26	2	2.2 μ F \pm 10% ceramic capacitors (0603) Murata GRM188R61C225KE15D
C27	0	Not installed, ceramic capacitor (0402)
D3, D4	2	Diodes Panasonic MA27P0100L

DESIGNATION	QTY	DESCRIPTION
D5	0	Laser, user supplied
J1, J19	2	SMB connectors, PC mount vertical Johnson 131-1701-201
J9, J17, TP1, TP2, TP3, TP5, TP15, TP16, TP23	9	Test points Keystone 5000
J23–J26	4	SMA connectors, edge mount, tab contact Johnson 142-0701-851
JP1	1	2-pin header, 0.1in center Sullins PEC36SAAN
JP4, JP5, JP6, JP30, JP33	5	3-pin headers, 0.1in center Sullins PEC36SAAN
JP1, JP4, JP5, JP6, JP30, JP33	6	Shunts Sullins SSC02SYAN
L1	1	10nH \pm 5% inductor (0402) Murata LQG15HS10NJ02
R1, R3	2	15 Ω \pm 5% resistors (0402)
R2	1	10 Ω \pm 5% resistor (0402)
R12, R126	2	5.6 Ω \pm 5% resistors (0402)
R17, R42, R50, R53, R58, R61, R72	7	1.0k Ω \pm 5% resistors (0603)
R20, R52	2	50k Ω variable resistors Bourns 3296W-1-503LF
R43	1	20k Ω variable resistor Bourns 3296W-1-203LF

Evaluates: MAX3643



MAX3643 Evaluation Kit

Component List (continued)

DESIGNATION	QTY	DESCRIPTION
R51, R54	0	Not installed, resistors (0603)
R66	1	3k Ω \pm 5% resistor (0603)
R91, R92, R94, R95, R97, R98, R100, R101	0	Not installed, resistors (0402)
R103, R104	2	100 Ω \pm 1% resistors (0402)
R113–R116	4	0 Ω \pm 5% resistors (0402)

DESIGNATION	QTY	DESCRIPTION
R121	1	75 Ω \pm 5% resistor (0402)
U1	1	Burst-mode laser driver (24 TQFN-EP*) Maxim MAX3643ETG+
—	1	PCB: MAX3643 EVALUATION BOARD+, Rev C

*EP = Exposed pad.

Quick Start

To evaluate the MAX3643 with a laser diode, configure the EV kit as follows:

- Pull shunts off all jumpers (JP5, JP33, JP30, JP4, JP6, and JP1).
- Set RBIASSET to 10k Ω by adjusting the BIASSET variable resistor R52 until the measured resistance between the VAR pin of jumper JP5 and GND is 10k Ω . Then install a shunt on the VAR side of jumper JP5.
- Connect the VBSET pin to the VREF pin by installing a shunt on the VREF side of jumper JP33.
- Connect the VMSET pin to the VREF pin by installing a shunt on the VREF side of jumper JP30.
- Set RMODSET to 5k Ω by adjusting the MODSET variable resistor R20 until the measured resistance between the VAR pin of jumper JP4 and GND is 5k Ω . Then install a shunt on the VAR side of jumper JP4.
- Set the total R_{IMAX} to 5k Ω by adjusting the IMAX variable resistor R43 until the measured resistance between the lower pin of jumper JP1 and GND is 2k Ω . Then install a shunt on jumper JP1.
- Connect the $\overline{\text{EN}}$ pin to GND by installing a shunt on the GND side of jumper JP6.
- Solder a laser to edge connection D5. See Figure 1 for a view of how the laser should be mounted on the EV kit. Be sure to keep the laser leads as short as possible to minimize parasitic inductance.
- Connect a differential data source to IN+ (J26) and IN- (J25) and a differential burst-enable source to BEN+ (J24) and BEN- (J23). Make sure the differential signals are between 200mV_{p-p} and 1600mV_{p-p} and the common mode is between (V_{CC} - 1.49V) and (V_{CC} - V_{IN}/4). See the *Applications Information* section for more options.
- Attach a +3.3V power supply to J9 (+3.3V) and J17 (GND). Set the current limit to 250mA.
- Connect the output of the user-supplied laser to an optical-to-electrical converter that has the appropriate bandwidth (filter) for the intended application.
- Turn on the power supply and adjust the BIASSET (R52) and MODSET (R20) variable resistors for the desired average optical power and extinction ratio. Turning the variable resistors clockwise increases bias and modulation current. In a DC-coupled open-loop configuration, MODSET affects the P1 power level and BIASSET affects the average power level, i.e., P0 and P1 move together as the resistance on BIASSET is adjusted. If the laser is not putting out any power or the driver output shuts down when the bias or modulation currents are increased, the R_{IMAX} resistance could be set too high.
- If the eye diagram contains too much overshoot or the rise/fall times are too slow, experimentally adjust the values of the RL peaking network (R3, L1) and RC shunt network (R121, C24) to better match the characteristics of the laser.

MAX3643 Evaluation Kit

Evaluates: MAX3643

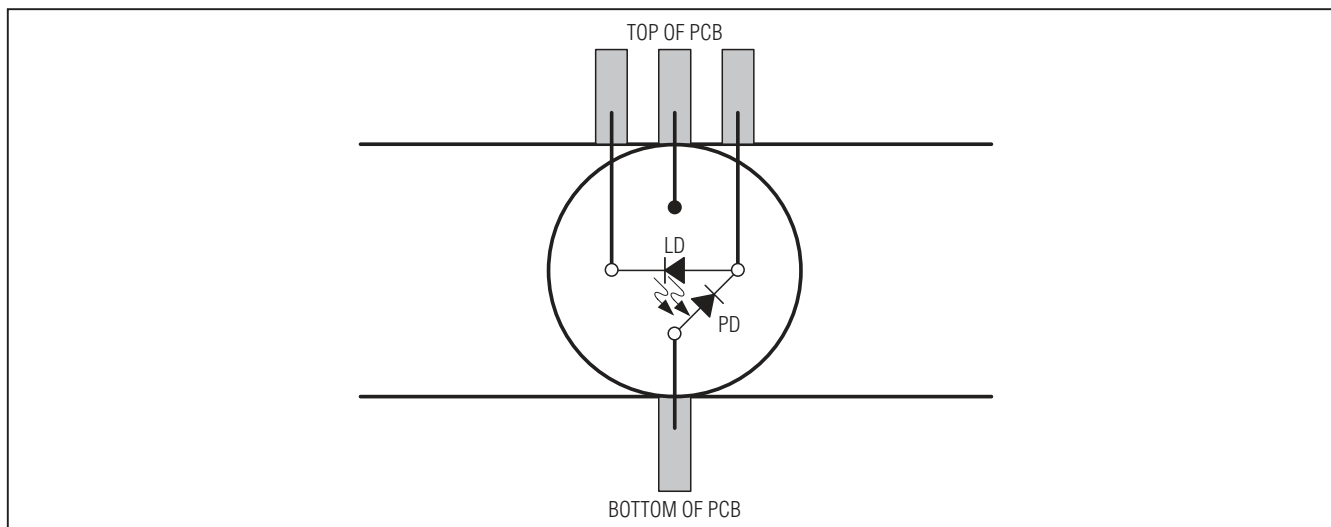

Figure 1. Laser Attachment

Applications Information

Continuous Mode Operation

For continuous mode operation, switch the differential burst-enable input (BEN±) to a constant high in one of two ways:

- Remove resistor R103. Install a 1kΩ resistor on R101 and 3kΩ resistors on R91, R92, and R100.
- Connect a +2.3V supply to BEN+ and a +1.7V supply to BEN- (or a differential 0.6V supply between BEN+ and BEN-).

LVPECL Input Terminations

If needed, an LVPECL Thevenin equivalent load termination of 50Ω to (VCC - 2V) can be created by doing the following:

- Remove resistors R103 and R104.
- Solder 130Ω resistors on R92, R94, R98, and R101.
- Solder 82Ω resistors on R91, R95, R97, and R100.

For more information, refer to Application Note 291: *HFAN-01.0: Introduction to LVDS, PECL, and CML*.

LVC MOS Burst Enable

To drive the burst-enable input (BEN+) with single-ended LVC MOS levels, do the following:

- Remove resistors R103 and R114.
- Solder 3kΩ resistor on R114.
- Solder 5kΩ resistors on R101 and R92.
- Solder 9kΩ resistor on R91.

Measuring MDOUT

The voltage at MDOUT is internally forced to 1.2V during the burst-on period. When the laser driver transitions to a burst-off period, the voltage at MDIN is sampled and then mirrored at MDOUT during the burst-off period. If the monitor diode has a high bandwidth, the MDIN voltage falls significantly while being sampled, resulting in a lower/inaccurate voltage at MDOUT. To compensate for this, solder a capacitor to C27. Start with 22pF and verify whether the voltage on MDIN reaches > 90% of steady state during the minimum burst-on period (use a high-impedance probe on MDIN). Maximizing the value of C27 while still making sure that the proper voltage during burst-on is reached at MDIN minimizes the amount of voltage error that occurs on MDOUT.

There is also a certain amount of voltage shifting that occurs burst-to-burst on MDOUT. The voltage shift is due to differences in data mark density during the burst-on period (see Figure 2). The fewer the number of bits in the burst-on period, the larger the voltage shifts at MDOUT. Therefore, it is necessary to filter or average the MDOUT voltage to reduce the shifting effects.

Note: The resistance at MDIN (RMDIN, R72) may need to be adjusted to obtain approximately 1.2V at MDIN during the burst-on time period. Setting the operating voltage at MDIN to 1.2V maximizes the margins for this pin and MDOUT. RMDIN can be computed by dividing 1.2V by the expected monitor diode current at the nominal average operating laser power. Setting the operating point at 1.2V causes any droop up or down of MDOUT to be minimized.

MAX3643 Evaluation Kit

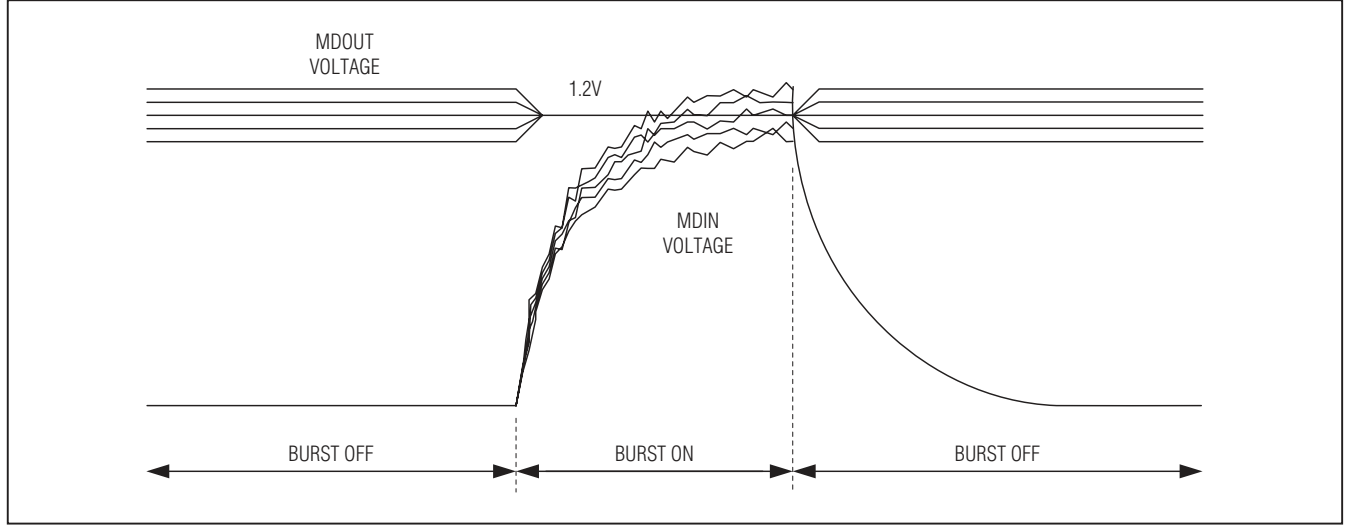

Figure 2. Relationship Between MDIN and MDOUT Voltage

Controlling I_{BIAS} and I_{MOD} from External Voltages

The bias and modulation current can be controlled from external sources by applying control voltages at TP23 (for controlling bias current) and TP15 (for controlling modulation current). Jumpers JP33 and JP30 must be set properly when driving TP23 and TP15 (see Table 1).

When setting the bias and modulations currents using VMSET and VBSET, the following equations can be used to determine the driver output currents:

$$I_{BIAS} = \frac{V_{VBSET}}{R_{BIASSET} + 50\Omega} \times 88$$

$$I_{MOD} = \frac{V_{VMSET}}{R_{MODSET} + 50\Omega} \times 88$$

Note: The 50Ω resistances in these equations are the internal resistances on the BIASSET and MODSET pins. The usable voltage range on VBSET and VMSET is 5mV to 1.4V.

Table 1. Adjustment and Control Descriptions

COMPONENT	NAME	FUNCTION
J1	BENOUT	The BENOUT voltage can be monitored by a high-impedance oscilloscope at this SMB connector.
J19	MDOUT	The MDOUT voltage can be monitored by a high-impedance oscilloscope at this SMB connector.
JP1	IMAX JUMPER	This jumper opens the connection to IMAX for measuring the IMAX variable resistor (R43).
JP4	MODSET SELECT	This jumper connects a fixed resistance (R51, not installed) or a variable resistance (R50 + R20) between the MODSET pin and GND.
JP5	BIASSET SELECT	This jumper connects a fixed resistance (R54, not installed) or a variable resistance (R53 + R52) between the BIASSET pin and GND.
JP6	\overline{EN}	This jumper connects the \overline{EN} pin to V _{CC} (driver disabled) or GND (driver enabled).
JP30	VMSET SELECT	This jumper connects the VMSET pin to the VREF pin or to test point TP15 for external control.

MAX3643 Evaluation Kit

Evaluates: MAX3643

Table 1. Adjustment and Control Descriptions (continued)

COMPONENT	NAME	FUNCTION
JP33	VBSET SELECT	This jumper connects the VBSET pin to the VREF pin or to test point TP23 for external control.
R20	MODSET RESISTOR	This 50k Ω variable resistor, in addition to a 1k Ω series resistor (R50), sets the external resistance between the MODSET pin and GND when a shunt is installed on the VAR side of jumper JP4. Turning the variable resistor clockwise increases the modulation current.
R43	IMAX RESISTOR	This 20k Ω variable resistor, in addition to a 3k Ω series resistor (R66), sets the resistance between the IMAX pin and GND. Turning the variable resistor clockwise increases the laser current limit.
R52	BIASSET RESISTOR	This 50k Ω variable resistor, in addition to a 1k Ω series resistor (R53), sets the external resistance between the BIASSET pin and GND when a shunt is installed on the VAR side of jumper JP5. Turning the variable resistor clockwise increases the bias current.
TP1	VREF	Monitoring point for the voltage at VREF.
TP5	BCMON	Monitoring point for the voltage at BCMON.
TP15	VMSET	Connection point for driving the VMSET pin. To use this test point a shunt must be installed on the V_TP15 side of jumper JP30.
TP16	MDIN	Monitoring point for the voltage at MDIN.
TP23	VBSET	Connection point for driving the VBSET pin. To use this test point a shunt must be installed on the V_TP23 side of jumper JP33.

MAX3643 Evaluation Kit

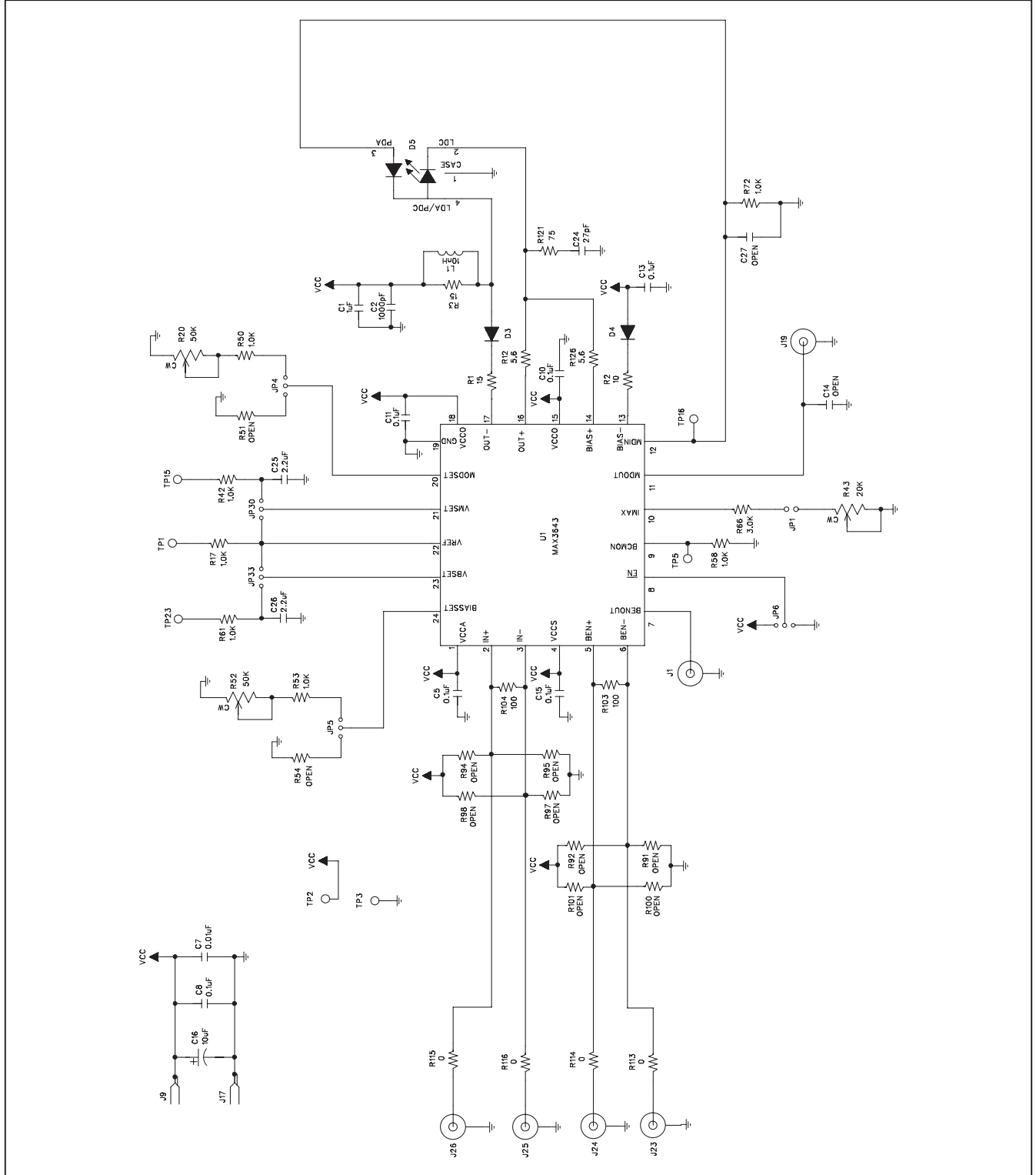

Figure 3. MAX3643 EV Kit Schematic

MAX3643 Evaluation Kit

Evaluates: **MAX3643**

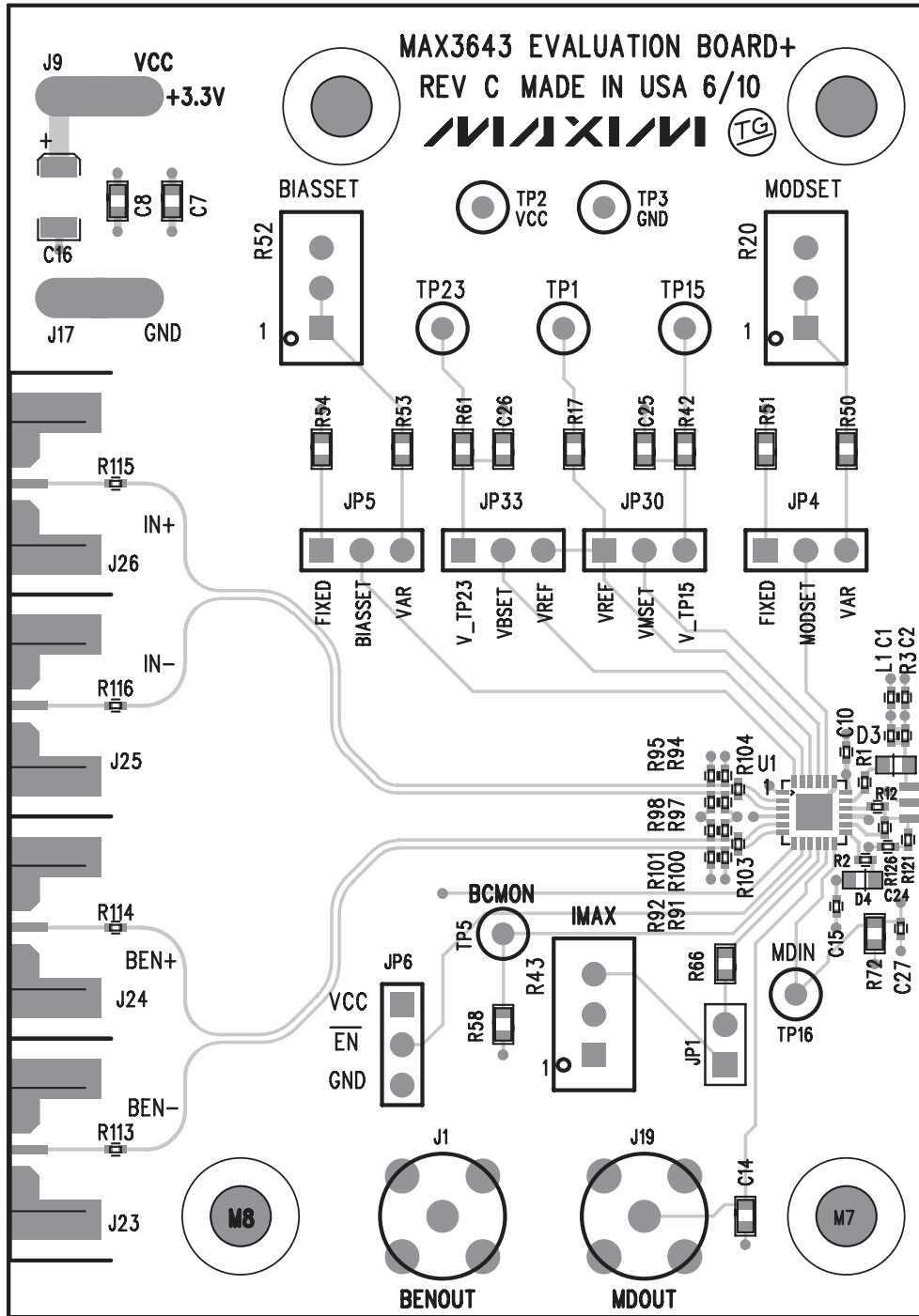

Figure 4. MAX3643 EV Kit Component Placement Guide—Component Side

MAX3643 Evaluation Kit

Evaluates: MAX3643

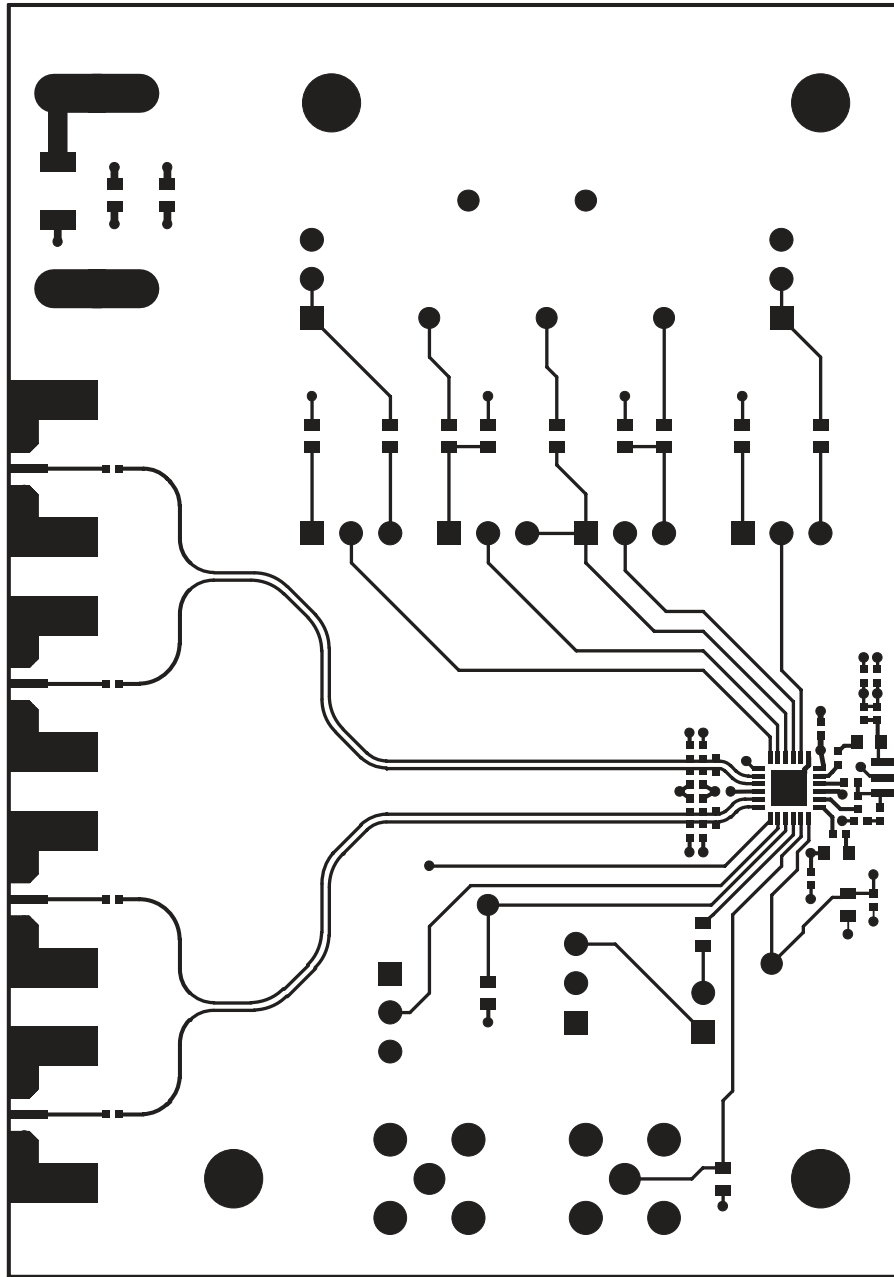

Figure 5. MAX3643 EV Kit PCB Layout—Component Side

MAX3643 Evaluation Kit

Evaluates: MAX3643

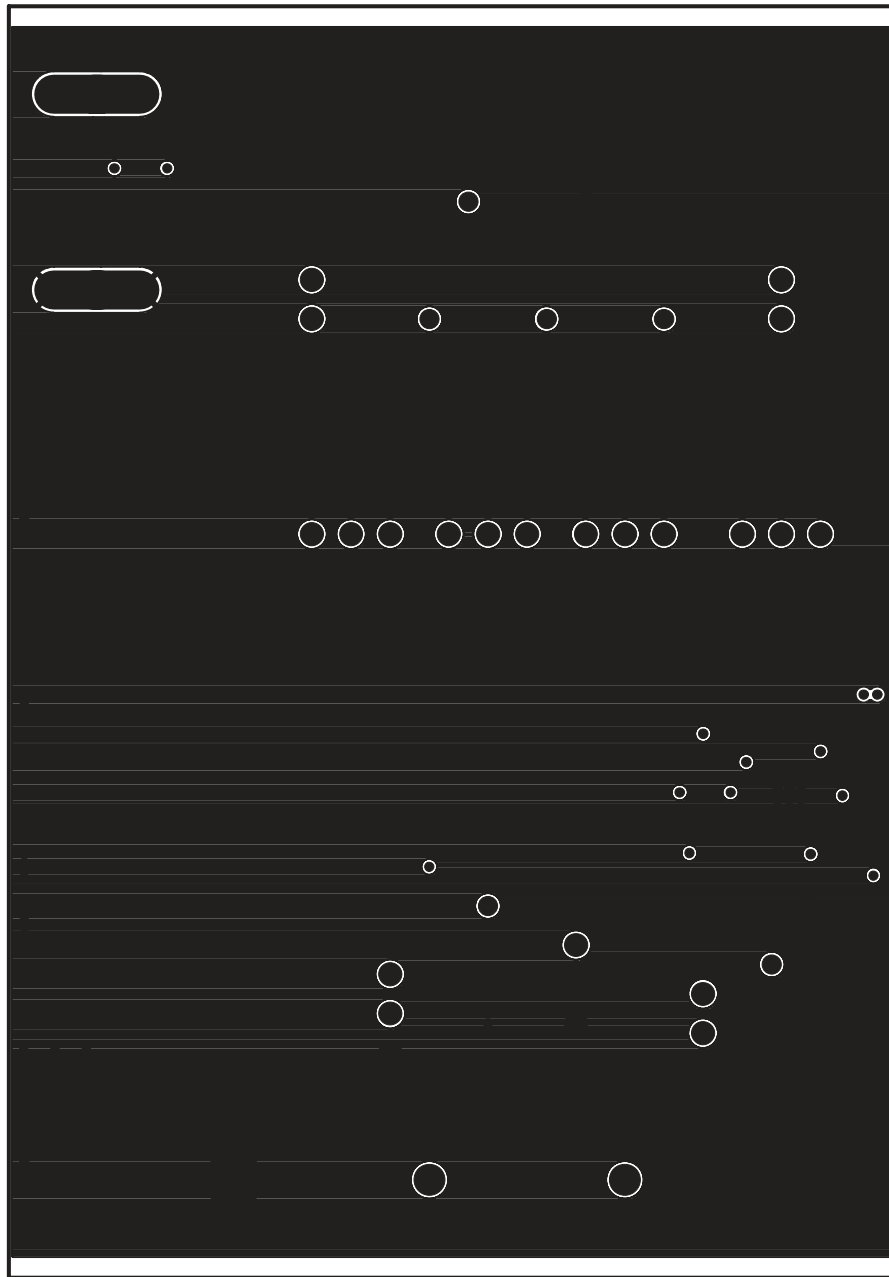

Figure 6. MAX3643 EV Kit PCB Layout—Ground Plane

MAX3643 Evaluation Kit

Evaluates: MAX3643

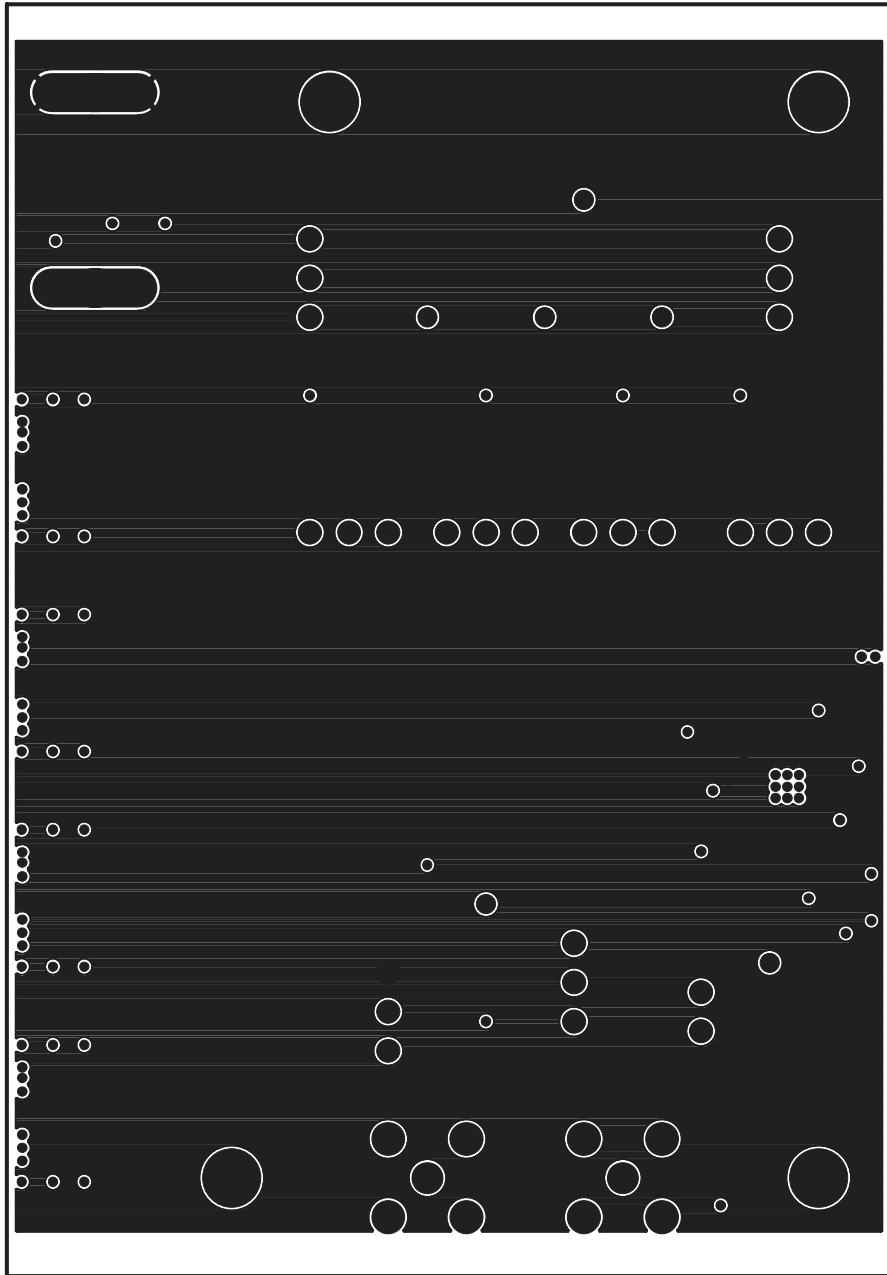

Figure 7. MAX3643 EV Kit PCB Layout—Power Plane

MAX3643 Evaluation Kit

Evaluates: MAX3643

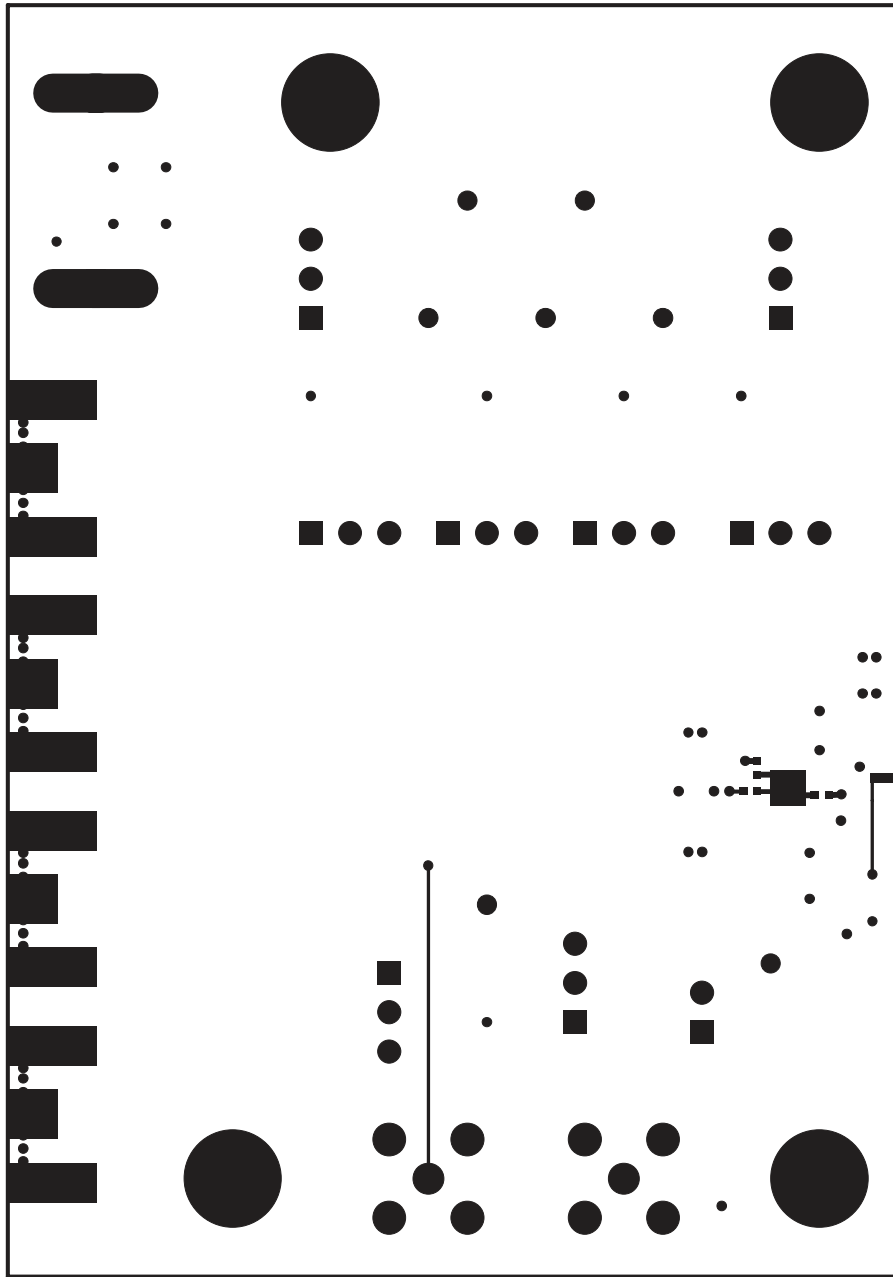

Figure 8. MAX3643 EV Kit PCB Layout—Solder Side

MAX3643 Evaluation Kit

Evaluates: MAX3643

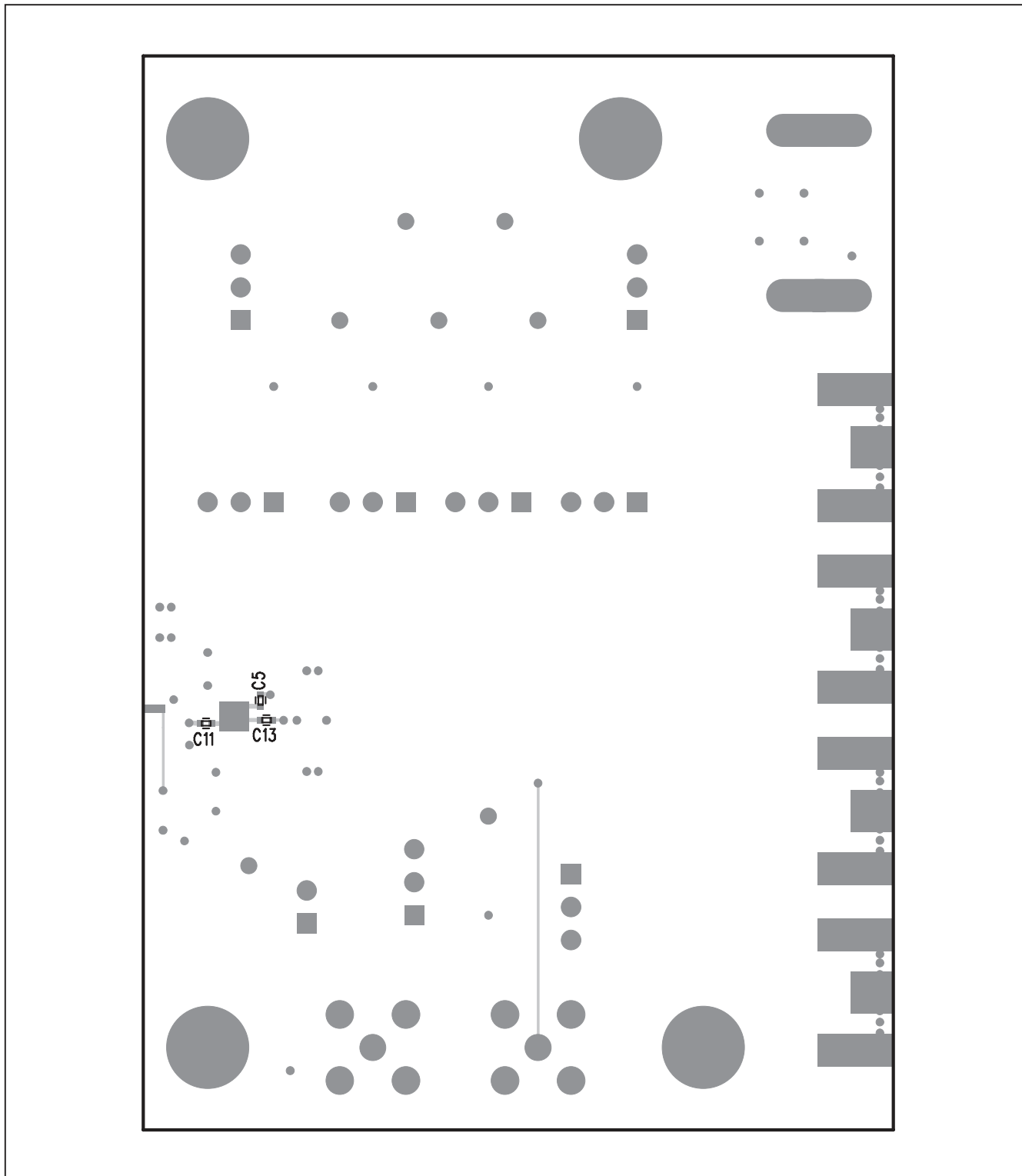

Figure 9. MAX3643 EV Kit Component Placement Guide—Solder Side

MAX3643 Evaluation Kit

Revision History

REVISION NUMBER	REVISION DATE	DESCRIPTION	PAGES CHANGED
0	11/05	Initial release	—
1	8/10	Redesigned the EV kit to work up to 2.5Gbps	All

Evaluates: MAX3643

Maxim cannot assume responsibility for use of any circuitry other than circuitry entirely embodied in a Maxim product. No circuit patent licenses are implied. Maxim reserves the right to change the circuitry and specifications without notice at any time.

Maxim Integrated Products, 120 San Gabriel Drive, Sunnyvale, CA 94086 408-737-7600 _____ 13