







Ferrites and accessories

RM 8, RM 8 LP
Core and accessories

Series/Type: **B65811, B65812**

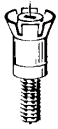
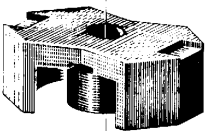
Date: **October 2022**

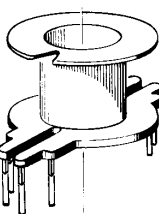
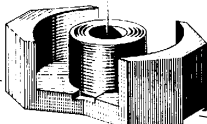
RM 8
Core and accessories

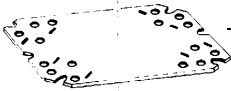
	Individual parts	Part no.	Page
	Adjusting screw	B65812	9
	Core	B65811	3
	Clamps	B65812	8
	Insulating washer 1	B65812	8
	Coil former	B65812	5
	Core	B65811	3
	Threaded sleeve (glued-in)		
	Insulating washer 2	B65812	8

FRM0051-5

Example of an assembly set

Also available:

Coil former for SMPS transformers	B65812	6
Coil former for power applications	B65812	7
<u>RM 8 low-profile:</u>		
Core	B65811P	10
Clamp	B65812	11
Insulating washers 1 + 2	B65812	11

RM 8
Core
B65811

- To IEC 63093-4
- Cores without center hole for transformer applications
- Delivery mode: sets

Magnetic characteristics (per set)

	with center hole	without center hole	
$\Sigma I/A$	0.68	0.59	mm ⁻¹
l_e	35.1	38	mm
A_e	52	64	mm ²
A_{min}	—	55	mm ²
V_e	1825	2430	mm ³

Approx. weight (per set)

m	10.7	12	g
---	------	----	---

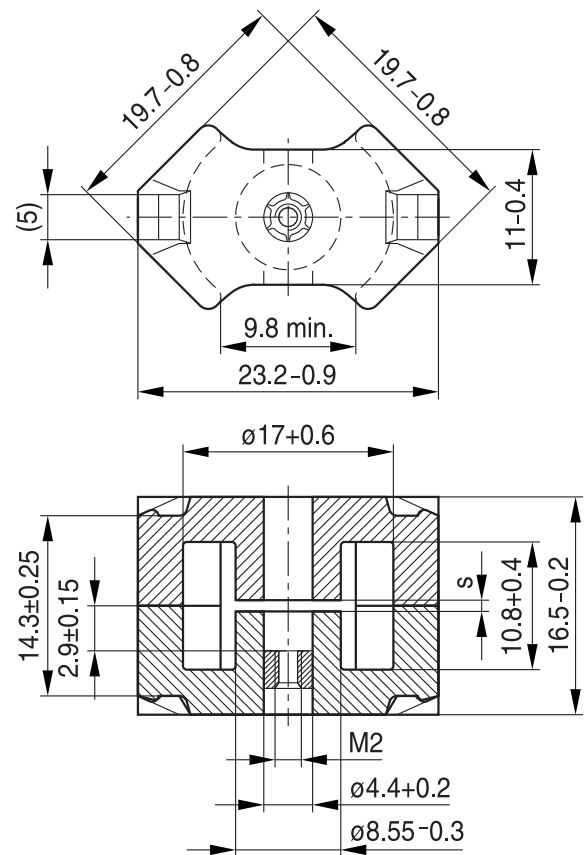
Gapped (A_L values/air gaps examples)

Material	A_L value	s approx. mm	μ_e	Ordering code ¹⁾ -D with center hole -F with threaded sleeve -J without center hole
	nH			
N48	250 ± 3%	0.23	134	B65811+0250A048
	315 ± 3%	0.17	169	B65811+0315A048
	400 ± 3%	0.14	215	B65811+0400A048
	630 ± 5%	0.10	338	B65811+0630J048
N41	160 ± 3%	0.49	76	B65811J0160A041
	250 ± 5%	0.24	118	B65811J0250J041
	630 ± 5%	0.11	298	B65811J0630J041
	1600 ± 10%	0.04	756	B65811J1600K041
N87	250 ± 3%	0.30	118	B65811J0250A087
	400 ± 3%	0.18	189	B65811J0400A087

1) Replace the + by the code letter "D", "F" or "J" for the required version. Standard version is "D".

RM 8
Core
B65811
Ungapped

Material	A _L value nH	μ _e	P _V W/set	Ordering code -D with center hole -J without center hole
PC200	1260 +30/-20%	600	< 0.70 (50 mT, 1000 kHz, 100 °C) < 0.90 (30 mT, 2000 kHz, 100 °C)	B65811J0000R608
N48	2900 +30/-20%	1550		B65811D0000R048
N30	5700 +30/-20%	2690		B65811J0000R030
T38	12500 +40/-30%	5910		B65811J0000Y038
N49	2200 +30/-20%	1040	< 0.37 (50 mT, 500 kHz, 100 °C)	B65811J0000R049
N87	3300 +30/-20%	1560	< 1.20 (200 mT, 100 kHz, 100 °C)	B65811J0000R087
N97	3300 +30/-20%	1560	< 1.00 (200 mT, 100 kHz, 100 °C)	B65811J0000R097
N41	4100 +30/-20%	1940	< 0.37 (200 mT, 25 kHz, 100 °C)	B65811J0000R041
N95	4100 +30/-20%	1940	< 1.10 (200 mT, 100 kHz, 100 °C) < 1.20 (200 mT, 100 kHz, 25 °C)	B65811J0000R095

Other A_L values/air gaps and materials available on request — see Processing remarks on page 12.

Coil former, squared pins

Material: GFR thermosetting plastic (UL 94 V-0, insulation class to IEC 60085:
 $F \triangleq$ max. operating temperature 155 °C), color code black
 Sumikon PM 9630® [E41429 (M)], SUMITOMO BAKELITE CO LTD

Solderability: to IEC 60068-2-20, test Ta, method 1 (aging 3): 235 °C, 2 s

Resistance to soldering heat: to IEC 60068-2-20, test Tb, method 1B: 350 °C, 3.5 s

Winding: see Processing notes, 2.1

For matching clamp and insulating washers see page 8.

Sections	A_N mm ²	l_N mm	A_R value $\mu\Omega$	Pins	Ordering code
1	30	42	47	5 8 12	B65812N1005D001 B65812N1008D001 B65812N1012D001
2	28.4	42	50	5 8 12	B65812N1005D002 B65812N1008D002 B65812N1012D002

12 pins

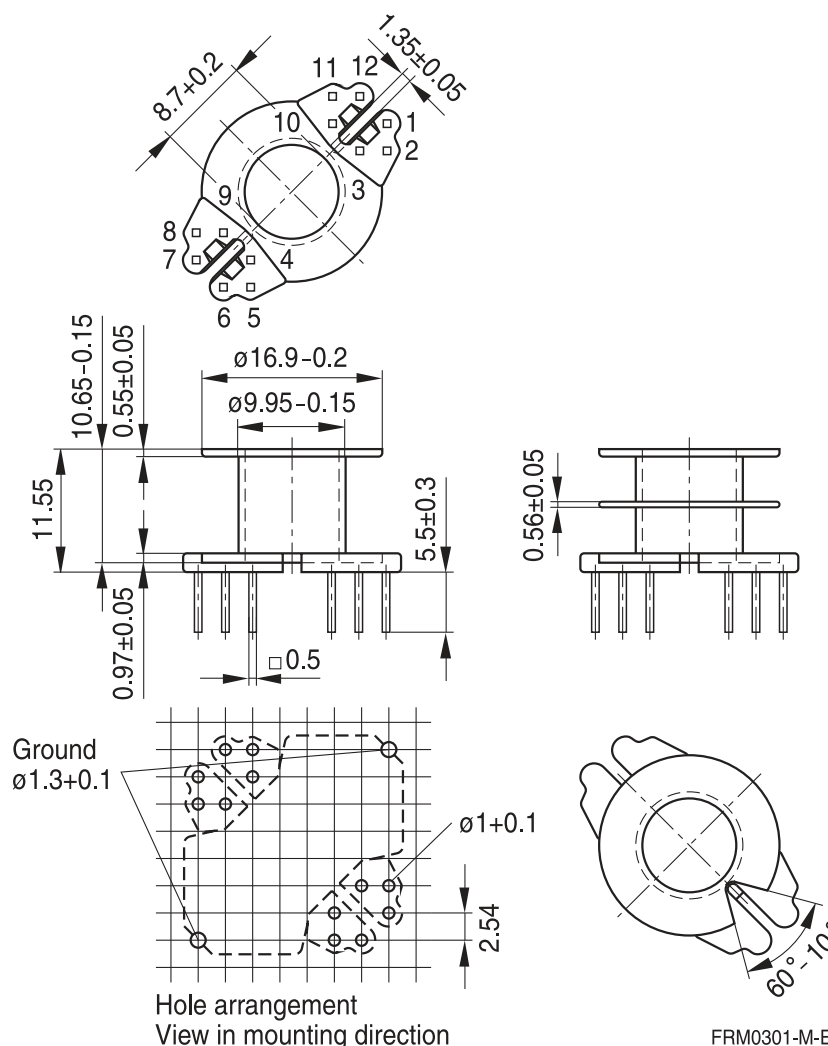

Version	Pins omitted
5 pins	3, 4, 6, 7, 9, 10, 12
8 pins	3, 4, 9, 10

Coil former for SMPS transformers with line isolation

The creepage distances and clearances are designed such that the coil former is suitable for use in SMPS transformers with line isolation.

- Closed center flange with external wire guide
- Optimized for use with automatic winding machines

Material: GFR thermosetting plastic (UL 94 V-0, insulation class to IEC 60085:
 $F \triangleq$ max. operating temperature 155 °C), color code black
 Sumikon PM 9630® [E41429 (M)], SUMITOMO BAKELITE CO LTD

Solderability: to IEC 60068-2-20, test Ta, method 1 (aging 3): 235 °C, 2 s

Resistance to soldering heat: to IEC 60068-2-20, test Tb, method 1B: 350 °C, 3.5 s

Winding: see Processing notes, 2.1

Sections	A_N mm ²	I_N mm	A_R value $\mu\Omega$	Pins	Ordering code
2	28.4	42	50	8	B65812N1108D002

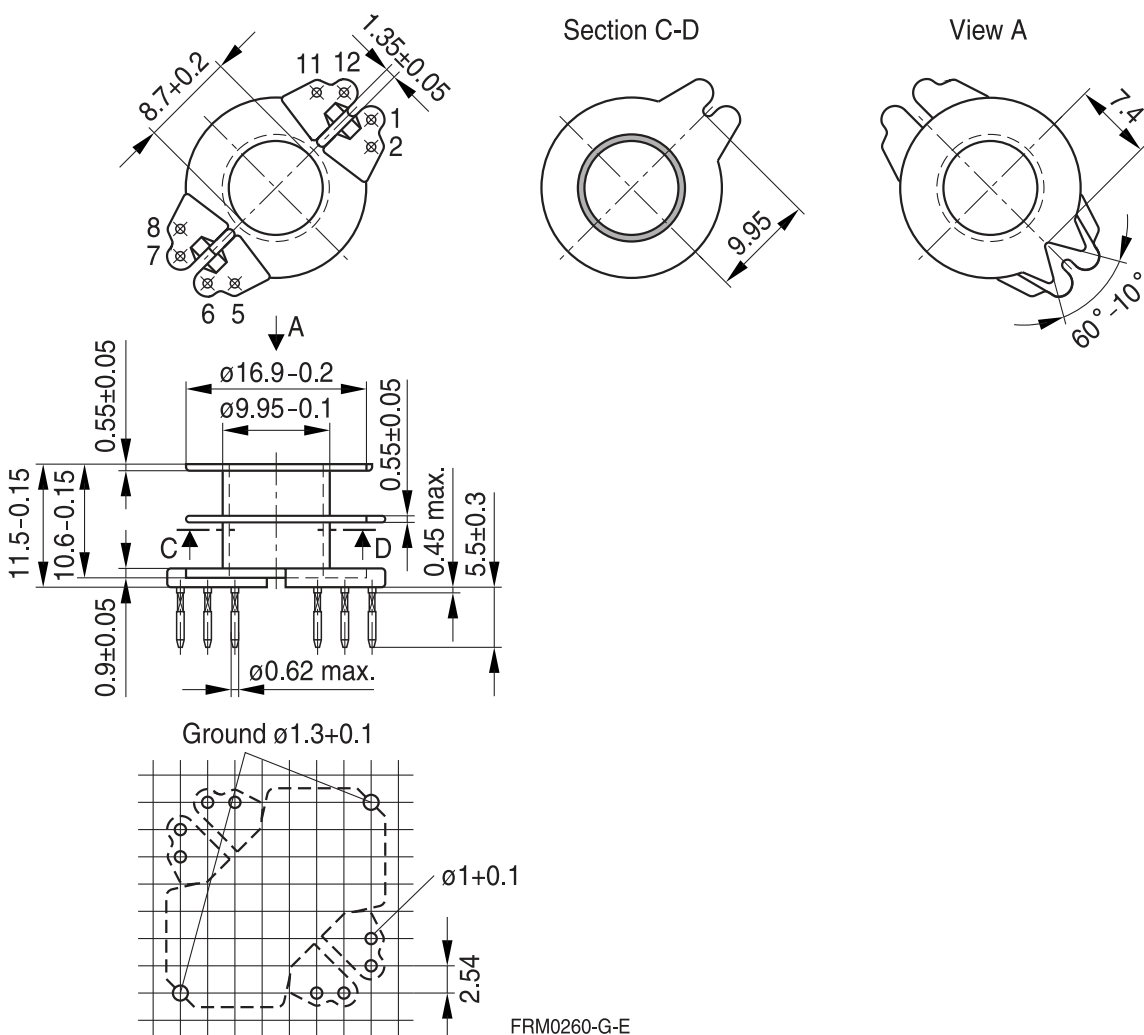

Coil former for power applications

Optimized for automatic winding

Material: GFR polyterephthalate (UL 94 V-0, insulation class to IEC 60085:

 $F \triangleq$ max. operating temperature 155 °C), color code black

Valox 420-SE0 [E45329 (M)] SABIC INNOVATIVE PLASTICS B V

Solderability: to IEC 60068-2-20, test Ta, method 1 (aging 3): 235 °C, 2 s

Resistance to soldering heat: to IEC 60068-2-20, test Tb, method 1B: 350 °C, 3.5 s

Winding: see Processing notes, 2.1

For matching clamp and insulating washer 1 see page 8.

Sections	A_N mm ²	l_N mm	A_R value $\mu\Omega$	Pins	Ordering code
1	30	42	47	12	B65812C1512T001

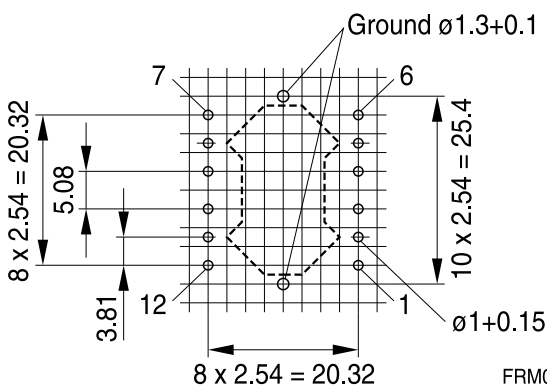
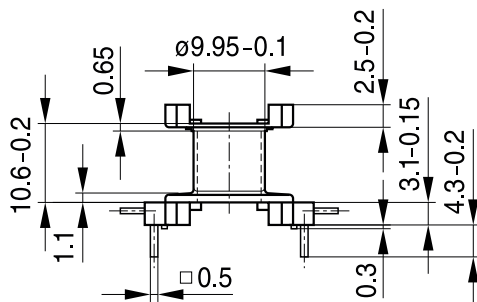
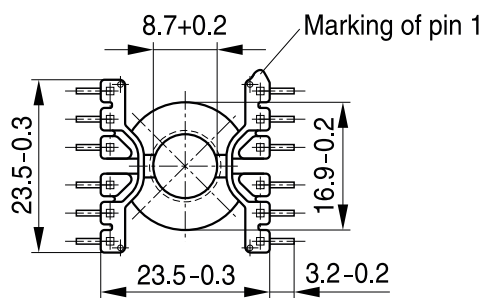

Hole arrangement
View in mounting direction
(Note half pitch!)

FRM0224-K-E

Clamp

- With ground terminal, made of stainless spring steel (tinned), 0.4 mm thick
- Solderability to IEC 60068-2-20, test Ta, method 1 (aging 3): 235 °C, 2 s

Insulating washer 1 between core and coil former

- For tolerance compensation and for insulation
- Made of polyimide film (max. temperature resistance 180 °C), 0.075 mm thick
Flexiso PI Fi 16000, amber color, Dr. Dietrich Müller GmbH

Insulating washer 2 for double-clad PCBs

- Made of polycarbonate (UL 94 V-0, insulation class to IEC 60085: E \geq 120 °C), 0.25 mm thick
Makrofol FR7-2 [E168120 (M)], COVESTRO AG

	Ordering code
Clamp (ordering code per piece, 2 are required)	B65812A2203X000
Insulating washer 1 (reel packing, PU = 1 reel)	B65812F5000X000
Insulating washer 2 (bulk)	B65812C2005X000

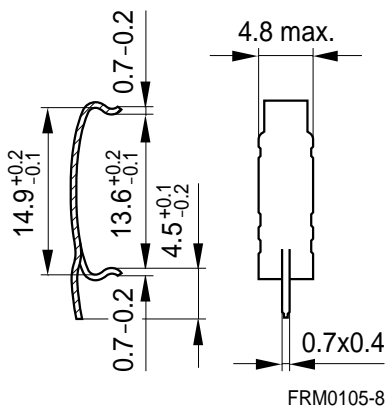
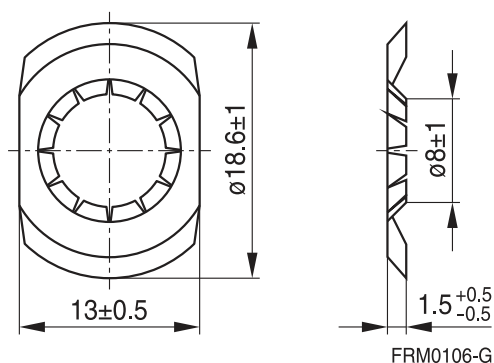
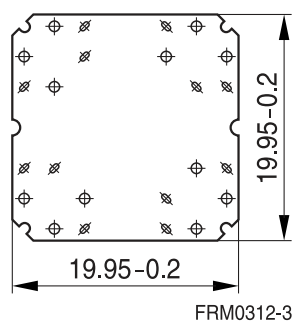
Clamp

Insulating washer 1

Insulating washer 2

RM 8
Accessories
B65812
Adjusting screw

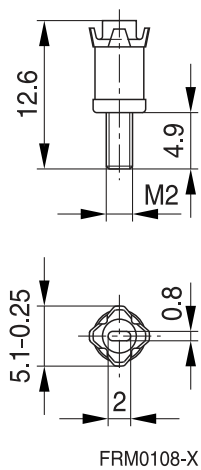
- Tube core with thread and core brake made of GFR polyterephthalate
Pocan B3235® [E245249 (M)], LANXESS AG

Tube core ∅ × length (mm)	Material	Color code	Ordering code
3.85 × 5.0	N22	gray	B65812B3003X022



RM 8 »Low Profile«
Core
B65811P

- To IEC 63093-4
- For compact transformers
- Without center hole
- Delivery mode: sets

Magnetic characteristics (per set)

$$\Sigma l/A = 0.44 \text{ mm}^{-1}$$

$$l_e = 28.7 \text{ mm}$$

$$A_e = 64.9 \text{ mm}^2$$

$$A_{\min} = 55.4 \text{ mm}^2$$

$$V_e = 1860 \text{ mm}^3$$

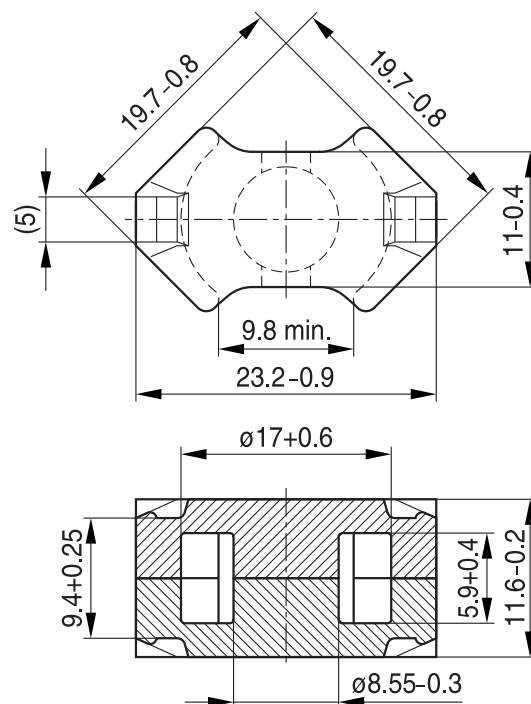
Approx. weight 10.6 g/set

FRM0353-5

Ungapped

Material	A_L value nH	μ_e	P_V W/set	Ordering code
N49	2900 +30/-20%	1020	< 0.33 (50 mT, 500 kHz, 100 °C)	B65811P0000R049
N92	3100 +30/-20%	1090	< 1.10 (200 mT, 100 kHz, 100 °C)	B65811P0000R092
N87	4100 +30/-20%	1440	< 0.92 (200 mT, 100 kHz, 100 °C)	B65811P0000R087

 Other A_L values/air gaps and materials available on request — see Processing remarks on page 12.

Clamp

- With ground terminal, made of stainless spring steel (tinned), 0.4 mm thick
- Solderability to IEC 60068-2-20, test Ta, method 1 (aging 3): 235 °C, 2 s

Insulating washer 1 between core and coil former

- For tolerance compensation and for insulation
- Made of polyimide film (max. temperature resistance 180 °C), 0.075 mm thick
Flexiso PI Fi 16000, amber color, Dr. Dietrich Müller GmbH

Insulating washer 2 for double-clad PCBs

- Made of polycarbonate (UL 94 V-0, insulation class to IEC 60085: E \geq 120 °C), 0.25 mm thick
Makrofol FR7-2 [E168120 (M)], COVESTRO AG

	Ordering code
Clamp (ordering code per piece, 2 are required)	B65812P2203X000
Insulating washer 1 (reel packing, PU = 1 reel)	B65812F5000X000
Insulating washer 2 (bulk)	B65812C2005X000

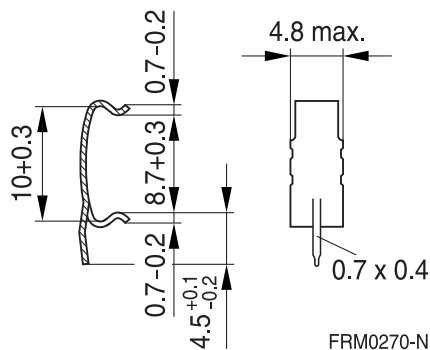
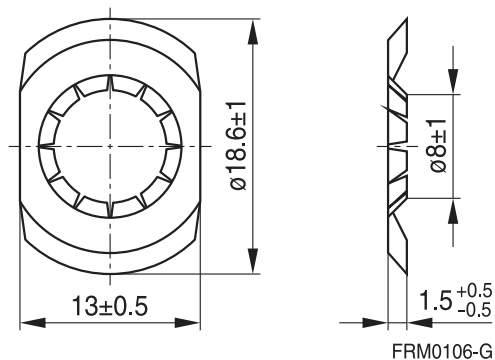
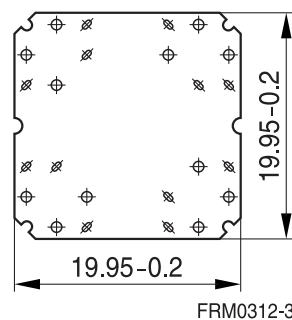
Clamp

Insulating washer 1

Insulating washer 2

Ferrites and accessories

Cautions and warnings

Mechanical stress and mounting

Ferrite cores have to meet mechanical requirements during assembling and for a growing number of applications. Since ferrites are ceramic materials one has to be aware of the special behavior under mechanical load.

As valid for any ceramic material, ferrite cores are brittle and sensitive to any shock, fast temperature changing or tensile load. Especially high cooling rates under ultrasonic cleaning and high static or cyclic loads can cause cracks or failure of the ferrite cores.

For detailed information see data book, chapter “*General - Definitions, 8.1*”.

Effects of core combination on A_L value

Stresses in the core affect not only the mechanical but also the magnetic properties. It is apparent that the initial permeability is dependent on the stress state of the core. The higher the stresses are in the core, the lower is the value for the initial permeability. Thus the embedding medium should have the greatest possible elasticity.

For detailed information see data book, chapter “*General - Definitions, 8.1*”.

Heating up

Ferrites can run hot during operation at higher flux densities and higher frequencies.

NiZn-materials

The magnetic properties of NiZn-materials can change irreversible in high magnetic fields.

Ferrite Accessories

Our ferrite accessories have been designed and evaluated only in combination with our ferrite cores. We explicitly point out that our ferrite accessories or our ferrite cores may not be compatible with those of other manufacturers. Any such combination requires prior testing by the customer and will be at the customer's own risk.

We assume no warranty or reliability for the combination of our ferrite accessories with cores and other accessories from any other manufacturer.

Processing remarks

The start of the winding process should be soft. Else the flanges may be destroyed.

- Too strong winding forces may blast the flanges or squeeze the tube that the cores can not be mounted any more.
- Too long soldering time at high temperature (>300 °C) may effect coplanarity or pin arrangement.
- Not following the processing notes for soldering of the J-leg terminals may cause solderability problems at the transformer because of pollution with Sn oxyde of the tin bath or burned insulation of the wire. For detailed information see chapter “*Processing notes*”, section 2.2.
- The dimensions of the hole arrangement have fixed values and should be understood as a recommendation for drilling the printed circuit board. For dimensioning the pins, the group of holes can only be seen under certain conditions, as they fit into the given hole arrangement. To avoid problems when mounting the transformer, the manufacturing tolerances for positioning the customers' drilling process must be considered by increasing the hole diameter.

Display of ordering codes for TDK Electronics products

The ordering code for one and the same product can be represented differently in data sheets, data books, other publications, on the company website or in order-related documents such as shipping notes, order confirmations and product labels. **The varying representations of the ordering codes are due to different processes employed and do not affect the specifications of the respective products.** Detailed information can be found on the Internet under www.tdk-electronics.tdk.com/orderingcodes.

Ferrites and accessories

Symbols and terms

Symbol	Meaning	Unit
A	Cross section of coil	mm ²
A _e	Effective magnetic cross section	mm ²
A _L	Inductance factor; $A_L = L/N^2$	nH
A _{L1}	Minimum inductance at defined high saturation ($\cong \mu_a$)	nH
A _{min}	Minimum core cross section	mm ²
A _N	Winding cross section	mm ²
A _R	Resistance factor; $A_R = R_{Cu}/N^2$	$\mu\Omega = 10^{-6} \Omega$
B	RMS value of magnetic flux density	Vs/m ² , mT
ΔB	Flux density deviation	Vs/m ² , mT
\hat{B}	Peak value of magnetic flux density	Vs/m ² , mT
$\Delta \hat{B}$	Peak value of flux density deviation	Vs/m ² , mT
B _{DC}	DC magnetic flux density	Vs/m ² , mT
B _R	Remanent flux density	Vs/m ² , mT
B _S	Saturation magnetization	Vs/m ² , mT
C ₀	Winding capacitance	F = As/V
CDF	Core distortion factor	mm ^{-4.5}
DF	Relative disaccommodation coefficient $DF = d/\mu_i$	
d	Disaccommodation coefficient	
E _a	Activation energy	J
f	Frequency	s ⁻¹ , Hz
f _{cutoff}	Cut-off frequency	s ⁻¹ , Hz
f _{max}	Upper frequency limit	s ⁻¹ , Hz
f _{min}	Lower frequency limit	s ⁻¹ , Hz
f _r	Resonance frequency	s ⁻¹ , Hz
f _{Cu}	Copper filling factor	
g	Air gap	mm
H	RMS value of magnetic field strength	A/m
\hat{H}	Peak value of magnetic field strength	A/m
H _{DC}	DC field strength	A/m
H _c	Coercive field strength	A/m
h	Hysteresis coefficient of material	10 ⁻⁶ cm/A
h/ μ_i^2	Relative hysteresis coefficient	10 ⁻⁶ cm/A
I	RMS value of current	A
I _{DC}	Direct current	A
\hat{I}	Peak value of current	A
J	Polarization	Vs/m ²
k	Boltzmann constant	J/K
k ₃	Third harmonic distortion	
k _{3c}	Circuit third harmonic distortion	
L	Inductance	H = Vs/A

Ferrites and accessories

Symbols and terms

Symbol	Meaning	Unit
$\Delta L/L$	Relative inductance change	H
L_0	Inductance of coil without core	H
L_H	Main inductance	H
L_p	Parallel inductance	H
L_{rev}	Reversible inductance	H
L_s	Series inductance	H
l_e	Effective magnetic path length	mm
l_N	Average length of turn	mm
N	Number of turns	
P_{Cu}	Copper (winding) losses	W
P_{trans}	Transferrable power	W
P_V	Relative core losses	mW/g
PF	Performance factor	
Q	Quality factor ($Q = \omega L/R_s = 1/\tan \delta_L$)	
R	Resistance	Ω
R_{Cu}	Copper (winding) resistance ($f = 0$)	Ω
R_h	Hysteresis loss resistance of a core	Ω
ΔR_h	R_h change	Ω
R_i	Internal resistance	Ω
R_p	Parallel loss resistance of a core	Ω
R_s	Series loss resistance of a core	Ω
R_{th}	Thermal resistance	K/W
R_V	Effective loss resistance of a core	Ω
s	Total air gap	mm
T	Temperature	$^{\circ}\text{C}$
ΔT	Temperature difference	K
T_C	Curie temperature	$^{\circ}\text{C}$
t	Time	s
t_v	Pulse duty factor	
$\tan \delta$	Loss factor	
$\tan \delta_L$	Loss factor of coil	
$\tan \delta_r$	(Residual) loss factor at $H \rightarrow 0$	
$\tan \delta_e$	Relative loss factor	
$\tan \delta_h$	Hysteresis loss factor	
$\tan \delta/\mu_i$	Relative loss factor of material at $H \rightarrow 0$	
U	RMS value of voltage	V
\hat{U}	Peak value of voltage	V
V_e	Effective magnetic volume	mm^3
Z	Complex impedance	Ω
Z_n	Normalized impedance $ Z _n = Z /N^2 \times \varepsilon (l_e/A_e)$	Ω/mm

Ferrites and accessories

Symbols and terms

Symbol	Meaning	Unit
α	Temperature coefficient (TK)	1/K
α_F	Relative temperature coefficient of material	1/K
α_e	Temperature coefficient of effective permeability	1/K
ϵ_r	Relative permittivity	
Φ	Magnetic flux	Vs
η	Efficiency of a transformer	
η_B	Hysteresis material constant	mT ⁻¹
η_i	Hysteresis core constant	A ⁻¹ H ^{-1/2}
λ_s	Magnetostriction at saturation magnetization	
μ	Relative complex permeability	
μ_0	Magnetic field constant	Vs/Am
μ_a	Relative amplitude permeability	
μ_{app}	Relative apparent permeability	
μ_e	Relative effective permeability	
μ_i	Relative initial permeability	
μ_p'	Relative real (inductive) component of $\bar{\mu}$ (for parallel components)	
μ_p''	Relative imaginary (loss) component of $\bar{\mu}$ (for parallel components)	
μ_r	Relative permeability	
μ_{rev}	Relative reversible permeability	
μ_s'	Relative real (inductive) component of $\bar{\mu}$ (for series components)	
μ_s''	Relative imaginary (loss) component of $\bar{\mu}$ (for series components)	
μ_{tot}	Relative total permeability derived from the static magnetization curve	
ρ	Resistivity	Ωm^{-1}
$\Sigma l/A$	Magnetic form factor	mm ⁻¹
τ_{Cu}	DC time constant $\tau_{Cu} = L/R_{Cu} = A_L/A_R$	s
ω	Angular frequency; $\omega = 2 \pi f$	s ⁻¹

All dimensions are given in mm.

SMD Surface-mount device

Important notes

The following applies to all products named in this publication:

1. Some parts of this publication contain **statements about the suitability of our products for certain areas of application**. These statements are based on our knowledge of typical requirements that are often placed on our products in the areas of application concerned. We nevertheless expressly point out **that such statements cannot be regarded as binding statements about the suitability of our products for a particular customer application**. As a rule, we are either unfamiliar with individual customer applications or less familiar with them than the customers themselves. For these reasons, it is always ultimately incumbent on the customer to check and decide whether a product with the properties described in the product specification is suitable for use in a particular customer application.
2. We also point out that **in individual cases, a malfunction of electronic components or failure before the end of their usual service life cannot be completely ruled out in the current state of the art, even if they are operated as specified**. In customer applications requiring a very high level of operational safety and especially in customer applications in which the malfunction or failure of an electronic component could endanger human life or health (e.g. in accident prevention or life-saving systems), it must therefore be ensured by means of suitable design of the customer application or other action taken by the customer (e.g. installation of protective circuitry or redundancy) that no injury or damage is sustained by third parties in the event of malfunction or failure of an electronic component.
3. **The warnings, cautions and product-specific notes must be observed.**
4. In order to satisfy certain technical requirements, **some of the products described in this publication may contain substances subject to restrictions in certain jurisdictions (e.g. because they are classed as hazardous)**. Useful information on this will be found in our Material Data Sheets on the Internet (www.tdk-electronics.tdk.com/material). Should you have any more detailed questions, please contact our sales offices.
5. We constantly strive to improve our products. Consequently, **the products described in this publication may change from time to time**. The same is true of the corresponding product specifications. Please check therefore to what extent product descriptions and specifications contained in this publication are still applicable before or when you place an order.
We also **reserve the right to discontinue production and delivery of products**. Consequently, we cannot guarantee that all products named in this publication will always be available. The aforementioned does not apply in the case of individual agreements deviating from the foregoing for customer-specific products.
6. Unless otherwise agreed in individual contracts, **all orders are subject to our General Terms and Conditions of Supply**.

7. **Our manufacturing sites serving the automotive business apply the IATF 16949 standard.**
The IATF certifications confirm our compliance with requirements regarding the quality management system in the automotive industry. Referring to customer requirements and customer specific requirements (“CSR”) TDK always has and will continue to have the policy of respecting individual agreements. Even if IATF 16949 may appear to support the acceptance of unilateral requirements, we hereby like to emphasize that **only requirements mutually agreed upon can and will be implemented in our Quality Management System.** For clarification purposes we like to point out that obligations from IATF 16949 shall only become legally binding if individually agreed upon.
8. The trade names EPCOS, CarXield, CeraCharge, CeraDiode, CeraLink, CeraPad, CeraPlas, CSMP, CTVS, DeltaCap, DigiSiMic, ExoCore, FilterCap, FormFit, InsuGate, LeaXield, MiniBlue, MiniCell, MKD, MKK, ModCap, MotorCap, PCC, PhaseCap, PhaseCube, PhaseMod, PhiCap, PowerHap, PQSine, PQvar, SIFERRIT, SIFI, SIKOREL, SilverCap, SIMDAD, SiMic, SIMID, SineFormer, SIOV, ThermoFuse, WindCap, XieldCap are **trademarks registered or pending** in Europe and in other countries. Further information will be found on the Internet at www.tdk-electronics.tdk.com/trademarks.

Release 2022-07