

IWTT SERIES

INDUSTRIAL WIRELESS TEMPERATURE TRANSDUCER



The IWTT Wireless Temperature Transducer is a cost effective replacement to a traditionally wired temperature transducer that offers the advantages of a low-cost installation in inaccessible and expensive installation environments.

It is easily paired to any of the range of IWR receivers - thus offering a “plug and play” solution to your pressure measurement applications.

The instrument uses either J or K type thermocouples or 3-wire RTD sensors fitted to an acetal housing giving excellent media compatibility for the harshest of applications. Compression fittings are available which allow the head to be orientated in the required direction.

The IWTT sensor can be used with any of the IWR range of receivers. A line-of-sight range of up to 500 m is possible depending on the wireless receiver used (refer to specific receiver data sheets for further information).

Each device is temperature compensated, calibrated and supplied with a traceable serial number.

Typical Applications Include

- Simple cable replacement installation
 - dispense with expensive cable runs
- Environmental monitoring
 - pumping stations, sewage plants, water treatment
- Facilities management
 - boiler rooms, plant hydraulics, plant pneumatics
- Asset monitoring
 - tanks farms, process plants, HVAC and building management
- Service Contract
 - temporary installation for servicing and field trials

Features

- K or J Type Thermocouples
- PT100 RTD Sensors
- 6 mm stainless steel sheath
- Up to 500 m line-of-site range (depending on receiver)
- Five year battery life at 10 second transmission update rate
- Simple DIL switch pairing with the single or five channel receiver
- Single, five and multi-channel channel receivers available (up to 128)
- User-selectable transmission update rates
- Analog digital, RS-232/485, Ethernet & USB receiver outputs
- Receiver clean contacts provide process alarm functions

System Performance

Accuracy (Non-linearity & Hysteresis)	<±0.1% /FS
Temperature Coefficient	±500ppm/°C

SPECIFICATIONS

Transmitter Temperature Ranges

Standard products are factory configured as below:

J-Type	0°C to +1200°C
K-Type	0°C to +1200°C
RTD Type	-200°C to +800°C

Instrument Power Source

Battery Type	User replaceable Lithium C cell
Battery Life	Five years at 10 second update rate
Battery Shelf Life	10 years

Material Specifications

Probe Sheath	316 Stainless Steel
"O" Ring Seals	Viton
Wireless Enclosure Material	Acetal
Weight	300g typical including battery
**Installation Position	Any
** Consult installation manual to ensure adequate signal path between transmitter and receiver.	

Receiver Output Signals

Receiver Part Number	Receiver Outputs
IoT Gateway	Built-in cellular modem allows all data to be sent to remote servers
IWR-PORT	RS-232 or RS-485 or Ethernet MODBUS Communications. Up to 128 off analog 4-20 mA or Relay outputs can be obtained by fitting extra ISOSLICE I/O modules
IWR-USB	Displays & Logs data on any PC running IWR-USB software
IWR-5	5 off 4-20 mA or 1-5 V dc and 1 Relay output
IWR-1	1 off 4-20 mA and 1-5 V dc and 1 Relay output
***Transmission Update Rate 1, 5, 10 and 30 seconds	
*** Consult installation manual for set-up:	
- Single channel system is DIL switch configurable	
- Five channel system requires set-up using "IWR Set" user software	

Transmitter Output

*Transmission Frequency	2.4 Ghz IEEE 802.15.4
Transmit Power	18 dBm
System Channel	User selectable via DIL switch
Antenna	Integral Odbi

*Compliant with EN 300 328, V1.8.1

Environmental Conditions & Thermal Effects

Media Temperature	-200°C to +1200°C
Op. /Ambient Temperature	-20°C to +50°C
Storage Temperature	-20°C to +80°C
Humidity	5% to 95% RH non-condensing
Thermal Span Shift	<±0.05% /°C typical

Mechanical Stability

See user manual

DIMENSIONS

All dimensions are in millimeters.

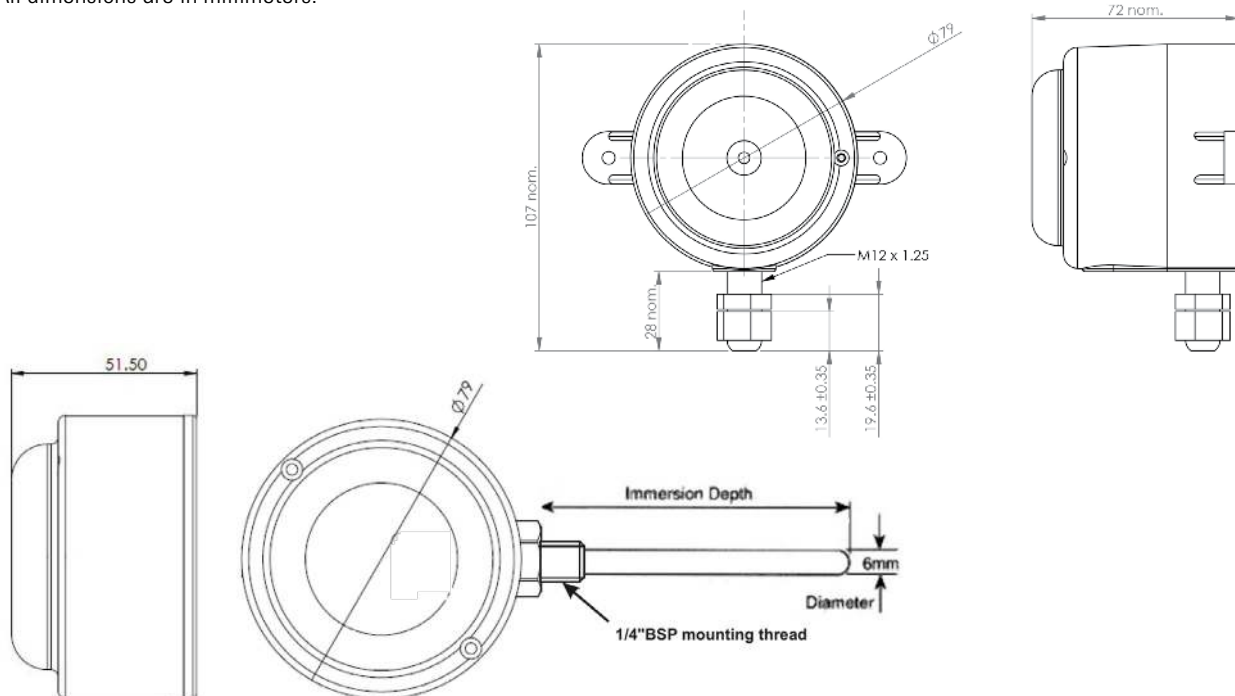



Temperature Transducer	See table below
Spare Battery	IBAT-1
Receivers	See IoT Gateway, IWR-PORT, IWR-USB, IWR-5 and IWR-1 data sheets
Five Channel Configuration Software* See Datasheet IWPTL	IWT-IWR Configuration Software (free download*)

*Free download user configuration software [here](#)

Part No.	Description	Part No.	Description
IWTTTP100A	PT100 6x100mm	IWTTJ200A	J type 6x200mm
IWTTTP150A	PT100 6x150mm	IWTTJ300A	J type 6x300mm
IWTTTP200A	PT100 6x200mm	IWTTJ400A	J type 6x400mm
IWTTTP250A	PT100 6x250mm	IWTTK150A	K type 6x150mm
IWTTTP300A	PT100 6x300mm	IWTTK200A	K type 6x200mm
IWTTTP400A	PT100 6x400mm	IWTTK300A	K type 6x300mm
		IWTTK400A	K type 6x400mm

Part No.	Description
IWTT-Node-J	Temperature transmitter J-type wireless 2.4GHz
IWTT-Node-K	Temperature transmitter K-type wireless 2.4GHz
IWTT-Node-PT	Temperature transmitter PT100-type wireless 2.4GHz

Made in the UK

Sensata Technologies, Inc. ("Sensata") data sheets are solely intended to assist designers ("Buyers") who are developing systems that incorporate Sensata products (also referred to herein as "components"). Buyer understands and agrees that Buyer remains responsible for using its independent analysis, valuation, and judgment in designing Buyer's systems and products. Sensata data sheets have been created using standard laboratory conditions and engineering practices. Sensata has not conducted any testing other than that specifically described in the published documentation for a particular data sheet. Sensata may make corrections, enhancements, improvements, and other changes to its data sheets or components without notice.

Buyers are authorized to use Sensata data sheets with the Sensata component(s) identified in each particular data sheet. HOWEVER, NO OTHER LICENSE, EXPRESS OR IMPLIED, BY ESTOPPEL OTHERWISE TO ANY OTHER SENSATA INTELLECTUAL PROPERTY RIGHT, AND NO LICENSE TO ANY THIRD PARTY TECHNOLOGY OR INTELLECTUAL PROPERTY RIGHT, IS GRANTED HEREIN. SENSATA DATA SHEETS ARE PROVIDED "AS IS". SENSATA MAKES NO WARRANTIES OR REPRESENTATIONS WITH REGARD TO THE DATA SHEETS OR USE OF THE DATA SHEETS, EXPRESS, IMPLIED, OR STATUTORY, INCLUDING ACCURACY OR COMPLETENESS. SENSATA DISCLAIMS ANY WARRANTY OF TITLE AND ANY IMPLIED WARRANTIES OF MERCHANTABILITY, FITNESS FOR A PARTICULAR PURPOSE, QUIET ENJOYMENT, QUIET POSSESSION, AND NON-INFRINGEMENT OF ANY THIRD PARTY INTELLECTUAL PROPERTY RIGHTS WITH REGARD TO SENSATA DATA SHEETS OR USE THEREOF.

All products are sold subject to Sensata's terms and conditions of sale supplied at www.sensata.com SENSATA ASSUMES NO LIABILITY FOR APPLICATIONS ASSISTANCE OR THE DESIGN OF BUYERS' PRODUCTS. BUYER ACKNOWLEDGES AND AGREES THAT IT IS SOLELY RESPONSIBLE FOR COMPLIANCE WITH ALL LEGAL, REGULATORY, AND SAFETY-RELATED REQUIREMENTS CONCERNING ITS PRODUCTS, AND ANY USE OF SENSATA COMPONENTS IN ITS APPLICATIONS, NOTWITHSTANDING ANY APPLICATIONS-RELATED INFORMATION OR SUPPORT THAT MAY BE PROVIDED BY SENSATA.

Mailing Address: Sensata Technologies, Inc., 529 Pleasant Street, Attleboro, MA 02703, USA

CONTACT US

EUROPE
+44 (0)1202 897969
c3w_sales@sensata.com
Cynergy3 Components Ltd.
7 Cobham Road,
Ferndown Industrial Estate,
Wimborne, Dorset,
BH21 7PE, United Kingdom

USA
+1 310 561 8092 / +1 866 258 5057
c3w_sales@sensata.com