

SQR-SD3M-8G1600SNL Datasheet

CONTENTS

1. Description..... 4
2. Features 4
3. Dimensions (millimeter) 5
4. Pin Identification 6
5. Pinouts 7
6. Parameter & Operating Conditions 8
Appendix: Part Number Table 14

Revision History

Rev.	Date	History
1.0	2013/4/26	1. 1 st release
1.1	2013/6/26	1. 2 nd release
1.2	2013/11/12	1. Correct operation temperature
1.3	2014/9/10	1. Update Operating Temperature Condition

Advantech reserves the right to make changes without further notice to any products or data herein to improve reliability, function, or design. Information furnished by Advantech is believed to be accurate and reliable. However, Advantech does not assure any liability arising out of the application or use of this information, nor the application or use of any product or circuit described herein, neither does it convey any license under its patent rights nor the rights of others.

Copyright © 1983-2014 Advantech Co., Ltd. All rights reserved.

1. Description

The SQR-SD3M-8G1600SNL DDR3 Industrial 1.35V SO-DIMM is high-speed, low power memory module that use 512Mx8bits DDR3 SDRAM in FBGA package and a 2048 bits serial EEPROM on a 204-pin printed circuit board. DDR3 Industrial 1.35V SO-DIMM is a Dual In-Line Memory Module and is intended for mounting into 204-pin edge connector sockets.

Synchronous design allows precise cycle control with the use of system clock. Data I/O transactions are possible on both edges of DQS. Range of operation frequencies, programmable latencies allow the same device to be useful for a variety of high bandwidth, high performance memory system applications.

2. Features

- Industrial Temperature : -20°C to +85°C
- Gold plating of PCB gold finger is 30u”
- RoHS compliant products.
- JEDEC standard 1.35V (1.28V~1.45V) Power supply
- JEDEC standard 1.5V (1.425V~1.575V) Power supply
- VDDQ= 1.35V (1.28V~1.45V) & 1.5V (1.425V~1.575V)
- Max clock Freq: 800MHZ for 1600Mb/s/Pin.
- Programmable CAS Latency: 5, 6, 7, 8, 9, 10, 11
- Programmable Additive Latency (Posted /CAS): 0, CL-2 or CL-1 clock
- Programmable /CAS Write Latency (CWL) = 8 (DDR3-1600)
- 8 bit pre-fetch
- Burst Length: 4, 8
- Bi-directional Differential Data-Strobe
- Internal calibration through ZQ pin
- On Die Termination with ODT pin
- Serial presence detect with EEPROM
- Asynchronous reset

3. Dimensions (millimeter)

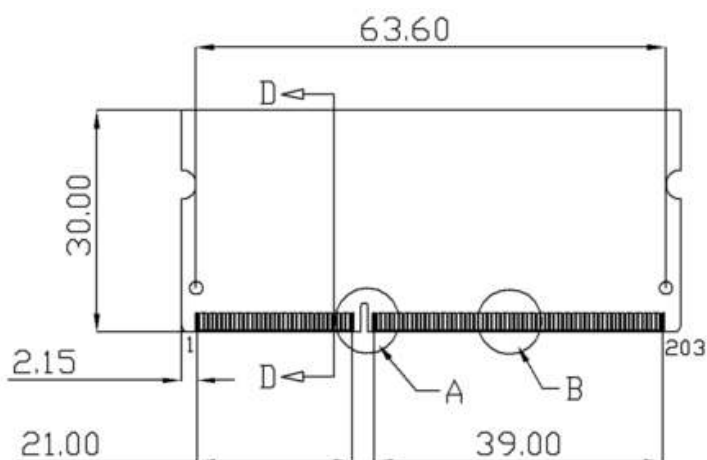

VIEW D-D

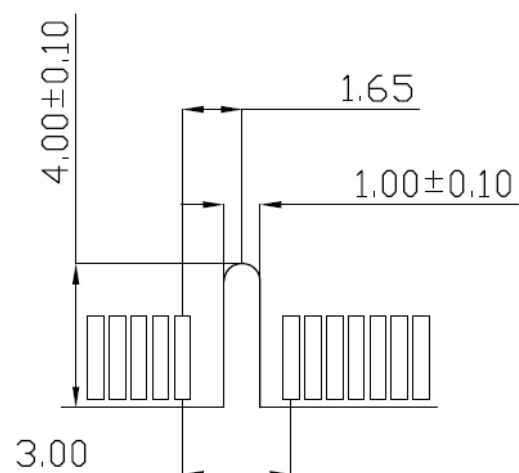
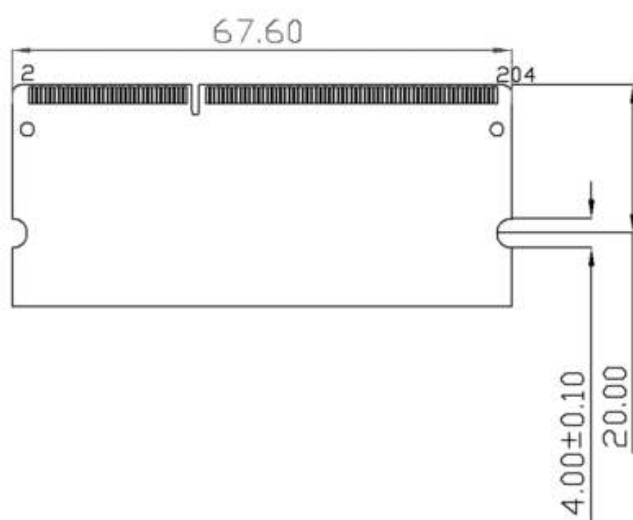
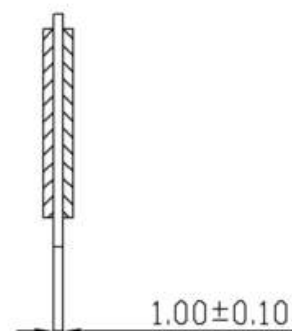

Detail A

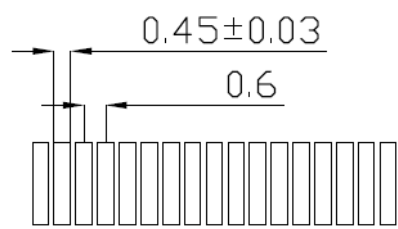

Detail B

4. Pin Identification

Symbol	Function
A0~A15, BA0~BA2	Address/Bank input
DQ0~DQ63	Data Input / Output.
DQS0~DQS7	Data strobe
/DQS0~/DQS7	Differential Data strobe
CK0, /CK0 CK1, /CK1	Clock Input. (Differential pair)
CKE0, CKE1	Clock Enable Input.
ODT0, ODT1	On-die termination control line
/CS0, /CS1	DIMM Rank Select Lines.
/RAS	Row Address Strobe
/CAS	Column Address Strobe
/WE	Write Enable
DM0~DM7	Data masks/high data strobes
VDD	Voltage power supply
VDDQ	Voltage Power Supply for DQS
VREF	Power Supply for Reference
VDDSPD	SPD EEPROM Power Supply
SA0~SA2	I2C serial bus address select for EEPROM
SCL	I2C serial bus clock for EEPROM
SDA	I2C serial bus data for EEPROM
VSS	Ground
/RESET	Set DRAMs Known State
VTT	SDRAM I/O termination supply
NC	No Connection

5. Pinouts

No.	Name	No.	Name	No.	Name	No.	Name	No.	Name	No.	Name
1	VREFDQ	69	DQ27	137	DQS4	2	VSS	70	DQ31	138	VSS
3	VSS	71	VSS	139	VSS	4	DQ4	72	VSS	140	DQ38
5	DQ0	73	CKE0	141	DQ34	6	DQ5	74	CKE1	142	DQ39
7	DQ1	75	VDD	143	DQ35	8	VSS	76	VDD	144	VSS
9	VSS	77	NC	145	VSS	10	DQS0	78	A15	146	DQ44
11	DM0	79	BA2	147	DQ40	12	/DQS0	80	A14	148	DQ45
13	VSS	81	VDD	149	DQ41	14	VSS	82	VDD	150	VSS
15	DQ2	83	A12	151	VSS	16	DQ6	84	A11	152	/DQS5
17	DQ3	85	A9	153	DM5	18	DQ7	86	A7	154	DQS5
19	VSS	87	VDD	155	VSS	20	VSS	88	VDD	156	VSS
21	DQ8	89	A8	157	DQ42	22	DQ12	90	A6	158	DQ46
23	DQ9	91	A5	159	DQ43	24	DQ13	92	A4	160	DQ47
25	VSS	93	VDD	161	VSS	26	VSS	94	VDD	162	VSS
27	/DQS1	95	A3	163	DQ48	28	DM1	96	A2	164	DQ52
29	DQS1	97	A1	165	DQ49	30	/RESET	98	A0	166	DQ53
31	VSS	99	VDD	167	VSS	32	VSS	100	VDD	168	VSS
33	DQ10	101	CK0	169	/DQS6	34	DQ14	102	CK1	170	DM6
35	DQ11	103	/CK0	171	DQS6	36	DQ15	104	/CK1	172	VSS
37	VSS	105	VDD	173	VSS	38	VSS	106	VDD	174	DQ54
39	DQ16	107	A10/AP	175	DQ50	40	DQ20	108	BA1	176	DQ55
41	DQ17	109	BA0	177	DQ51	42	DQ21	110	/RAS	178	VSS
43	VSS	111	VDD	179	VSS	44	VSS	112	VDD	180	DQ60
45	/DQS2	113	/WE	181	DQ56	46	DM2	114	/CS0	182	DQ61
47	DQS2	115	/CAS	183	DQ57	48	VSS	116	ODT0	184	VSS
49	VSS	117	VDD	185	VSS	50	DQ22	118	VDD	186	/DQS7
51	DQ18	119	A13	187	DM7	52	DQ23	120	ODT1	188	DQS7
53	DQ19	121	/CS1	189	VSS	54	VSS	122	NC	190	VSS
55	VSS	123	VDD	191	DQ58	56	DQ28	124	VDD	192	DQ62
57	DQ24	125	TEST	193	DQ59	58	DQ29	126	VREFCA	194	DQ63
59	DQ25	127	VSS	195	VSS	60	VSS	128	VSS	196	VSS
61	VSS	129	DQ32	197	SA0	62	/DQS3	130	DQ36	198	/EVENT
63	DM3	131	DQ33	199	VDDSPD	64	DQS3	132	DQ37	200	SDA
65	VSS	133	VSS	201	SA1	66	VSS	134	VSS	202	SCL
67	DQ26	135	/DQS4	203	Vtt	68	DQ30	136	DM4	204	Vtt

* Please refer Block Diagram

6. Parameter & Operating Conditions

Operating Temperature Condition

Parameter	Symbol	Rating	Unit	Notes
Operating Temperature	TOPER	-20 to 85	°C	1,2
Note: 1. Operating Temperature is the case surface temperature on the center/top side of the DRAM. For the measurement conditions, please refer to JESD51-2 standard. 2. At -20 - 85°C, operation temperature range are the temperature which all DRAM specification will be supported.				

Absolute Maximum DC Ratings

Parameter	Symbol	Value	Unit	Notes
Voltage on VDD relative to Vss	VDD	-0.4 ~ 1.975	V	1
Voltage on VDDQ pin relative to Vss	VDDQ	-0.4 ~ 1.975	V	1
Voltage on any pin relative to Vss	VIN, VOUT	-0.4 ~ 1.975	V	1
Storage temperature	TSTG	-55~+100	°C	1,2
Note: 1. Stress greater than those listed under “Absolute Maximum Ratings” may cause permanent damage to the stress rating only and functional operation of the device at these or any other conditions above those indicated in the operational sections of this specification is not implied. Exposure to absolute maximum rating conditions for extended periods may affect reliability. 2. Storage Temperature is the case surface temperature on the center/top side of the DRAM. For the measurement conditions, please refer to JESD51-2 standard.				

AC & DC Operating Conditions

Recommended DC operating conditions (SSTL –1.5)

Parameter	Symbol	Voltage	Rating			Unit	Notes
			Min	Typ.	Max		
Supply voltage	VDD	1.35V	1.283	1.35	1.45	V	1,2
		1.5V	1.425	1.5	1.575		
Supply voltage for Output	VDDQ	1.35V	1.283	1.35	1.45	V	1,2
		1.5V	1.425	1.5	1.575		
I/O Reference voltage (DQ)	VREF _{DQ} (DC)	1.35V	0.49*VDDQ	0.50*VDDQ	0.51*VDDQ	V	3
		1.5V					
I/O Reference voltage (CMD/ADD)	VREF _{CA} (DC)	1.35V	0.49*VDDQ	0.50*VDDQ	0.51*VDDQ	V	3
		1.5V					
AC Input logic high	VIH(AC)	1.35V	VREF+0.160	-		V	
		1.5V	VREF+0.175				
AC Input logic low	VIL(AC)	1.35V		-	VREF-0.160	V	
		1.5V			VREF-0.175		
DC Input logic high	VIH(DC)	1.35V	VREF+0.09	-	VDD	V	
		1.5V	VREF+0.1		VDD		
DC Input logic low	VIL(DC)	1.35V	VSS	-	VREF-0.09	V	
		1.5V	VSS		VREF-0.1		
Note: There is no specific device VDD supply voltage requirement for SSTL-1.5 compliance. 1. Under all conditions VDDQ must be less than or equal to VDD. 2. VDDQ tracks with VDD, AC parameters are measured with VDD and VDDQ tied together. 3. Peak to peak AC noise on VREF may not allow deviate from VREF(DC) by more than +/-1% VDD.							

IDD Specification parameters Definition

IDD values are for full operating range of voltage and Temperature

Parameter	Symbol	Max.	Unit
Operating One bank Active-Precharge current; tCK = tCK(IDD), tRC = tRC(IDD), tRAS = tRASmin(IDD); CKE is HIGH, CS\ is HIGH between valid commands; Address bus inputs are SWITCHING; Data bus inputs are SWITCHING	IDD0	760	mA
Operating One bank Active-read-Precharge current; IOU _T = 0mA; BL = 4, CL = CL(IDD), AL = 0; tCK = tCK(IDD), tRC = tRC (IDD), tRAS = tRASmin(IDD), tRCD = tRCD(IDD); CKE is HIGH, CS\ is HIGH between valid commands; Address bus inputs are SWITCHING; Data pattern is same as IDD4W	IDD1	856	mA
Precharge power-down current; All banks idle; tCK = tCK(IDD); CKE is LOW; Other control and address bus inputs are STABLE; Data bus inputs are FLOATING	IDD2P	592	mA
Precharge quiet standby current; All banks idle; tCK = tCK(IDD); CKE is HIGH, CS\ is HIGH; Other control and address bus inputs are STABLE; Data bus inputs are FLOATING	IDD2Q	752	mA
Precharge standby current; All banks idle; tCK = tCK(IDD); CKE is HIGH, CS\ is HIGH; Other control and address bus inputs are SWITCHING; Data bus inputs are SWITCHING	IDD2N	800	mA
Active power - down current; All banks open; tCK = tCK(IDD); CKE is LOW; Other control and address bus inputs are STABLE; Data bus inputs are FLOATING	IDD3P	1008	mA
Active standby current; All banks open; tCK = tCK(IDD), tRAS = tRASmax(IDD), tRP = tRP(IDD); CKE is HIGH, CS\ is HIGH between valid commands; Other control and address bus inputs are SWITCHING; Data bus inputs are SWITCHING	IDD3N	992	mA
Operating burst read current; All banks open, Continuous burst reads, IOU _T = 0mA; BL = 4, CL = CL(IDD), AL = 0; tCK = tCK(IDD), tRAS = tRASmax(IDD), tRP = tRP(IDD); CKE is HIGH, CS\ is HIGH between valid commands; Address bus inputs are SWITCHING; Data pattern is same as IDD4W	IDD4R	1,656	mA
Operating burst write current; All banks open, Continuous burst writes; BL = 4, CL = CL(IDD), AL = 0; tCK = tCK(IDD), tRAS = tRASmax(IDD), tRP = tRP(IDD); CKE is HIGH, CS\ is HIGH between valid commands; Address bus inputs are SWITCHING; Data bus inputs are SWITCHING IDD4R	IDD4W	1,480	mA
Burst refresh current; tCK = tCK(IDD); Refresh command at every tRFC(IDD) interval; CKE is HIGH, CS\ is HIGH between valid commands; Other control and address bus inputs are SWITCHING; Data bus inputs are SWITCHING	IDD5	1,920	mA
Self refresh current; CK and CK\ at 0V; CKE = 0.2V; Other control and address bus inputs are FLOATING; Data bus inputs are FLOATING	IDD6	352	mA
Operating bank interleave read current; All bank interleaving reads, IOU _T = 0mA; BL = 4, CL = CL(IDD), AL = tRCD(IDD)-1*tCK(IDD); tCK = tCK(IDD), tRC = tRC(IDD), tRRD = tRRD(IDD), tRCD = 1*tCK(IDD); CKE is HIGH, CS\ is HIGH between valid commands; Address bus inputs are STABLE during Deselects; Data pattern is same as IDD4R; Refer to the following page for detailed timing conditions	IDD7	2,480	mA
Note: 1. Module IDD was calculated on the basis of component IDD and can be differently measured according to DQ loading capacitor.			

Timing Parameters & Specifications

Parameter	Symbol	Min	Max	Unit
Average Clock Period, CL=7	tCK	1.25	<1.5	ns
CK high-level width	tCH	0.47	0.53	tCK
CK low-level width	tCL	0.47	0.53	tCK
DQS, /DQS to DQ skew, per group, per access	tDQSQ	-	100	ps
DQ output hold time from DQS, /DQS	tQH	0.38	-	tCK
DQ low-impedance time from CK, /CK	tLZ(DQ)	-450	225	ps
DQ high-impedance time from CK, /CK	tHZ(DQ)	-	225	ps
Data setup time to DQS, /DQS reference to Vih(ac)/Vil(ac) levels	tDS	10	-	ps
Data hold time to DQS, /DQS reference to Vih(ac)/Vil(ac) levels	tDH	45	-	ps
DQ and DM input pulse width for each input	tDIPW	360	-	ps
DQS, /DQS Read preamble	tRPRE	0.9	-	tCK
DQS, /DQS differential Read postamble	tRPST	0.3	-	tCK
DQS, /DQS Write preamble	tWPRE	0.9	-	tCK
DQS, /DQS Write postamble	tWPST	0.3	-	tCK
DQS, /DQS low-impedance time	tLZ(DQS)	-450	225	ps
DQS, /DQS high-impedance time	tHZ(DQS)	-	225	ps
DQS, /DQS differential input low pulse width	tDQSL	0.45	0.55	tCK
DQS, /DQS differential input high pulse width	tDQSH	0.45	0.55	tCK
DQS, /DQS rising edge to CK, /CK rising edge	tDQSS	-0.27	+0.27	tCK
DQS, /DQS falling edge setup time to CK, /CK rising edge	tDSS	0.18	-	tCK
DQS, /DQS falling edge hold time to CK, /CK rising edge	tDSH	0.18	-	tCK
Delay from start of Internal write transaction to Internal read command	tWTR	Max (4tck, 7.5ns)	-	
Write recovery time	tWR	15	-	ns
Mode register set command cycle time	tMRD	4	-	tCK
/CAS to /CAS command delay	tCCD	4	-	nCK
Auto precharge write recovery + precharge time	tDAL	tWR+tRP/tck		nCK
Active to active command period for 1KB page size	tRRD	Max (4tck, 6)	-	ns
Active to active command period for 2KB page size	tRRD	Max (4tck, 7.5)	-	ns
Four Activate Window for 1KB page size products	tFAW	30	-	ns
Four Activate Window for 2KB page size products	tFAW	40	-	ns
Power-up and RESET calibration time	tZQinitl	512	-	tCK
Normal operation Full calibration time	tZQoper	256	-	tCK
Normal operation short calibration time	tZQcs	64	-	tCK
Exit self refresh to commands not requiring a locked DLL	tXS	Max (5tCK, tRFC+10)	-	ns
Exit self refresh to commands requiring a locked DLL	tXSDLL	tDLL(min)	-	tCK

Specifications subject to change without notice, contact your sales representatives for the most update information.

Internal read to precharge command delay	tRTP	Max (4tCK, 7.5ns)	-	ns
Minimum CKE low width for Self refresh entry to exit timing	tCKESR	tCK(min)+1tCK	-	-
Exit power down with DLL to any valid command: Exit Precharge Power Down with DLL	tXP	Max (3tCK, 6ns)	-	-
CKE minimum pulse width (high and low pulse width)	tCKE	Max (3tCK, 5ns)		-
Asynchronous RTT turn-on delay (Power-Down mode)	tAONPD	2	8.5	ns
Asynchronous RTT turn-off delay (Power-Down mode)	tAOFPD	2	8.5	ns
ODT turn-on	tAON	-225	225	ps
ODT turn-off	tAOF	0.3	0.7	tCK

SERIAL PRESENCE DETECT SPECIFICATION

Serial Presence Detect			
Byte No.	Function Described	Standard Specification	Vendor Part
0	Number of SPD Bytes written / SPD device size / CRC coverage during module production	CRC:0-116Byte SPD Byte use: 176Byte SPD Byte total: 256Byte	92
1	SPD Revision	Version 1.0	10
2	Key Byte / DRAM Device Type	DDR3 SDRAM	0B
3	Key Byte / Module Type	SODIMM	03
4	SDRAM Density and Banks	4Gb 8banks	04
5	SDRAM Addressing	ROW:16, Column:10	21
6	Module Normal Voltage, VDD	1.35V and 1.5V	02
7	Module Organization	2Rank / x8	09
8	Module Memory Bus Width	Non ECC, 64bit	03
9	Fine Timebase Dividend and Divisor	2.5ps	52
10	Medium Timebase Dividend	0.125ns	01
11	Medium Timebase Divisor	0.125ns	08
12	SDRAM Minimum Cycle Time (tCKmin)	1.25ns	0A
13	Reserved	-	00
14	CAS Latencies Supported, Least Significant Byte	5, 6, 7, 8, 9, 10, 11	FE
15	CAS Latencies Supported, Most Significant Byte	-	00
16	Minimum CAS Latency Time (tAmin)	13.125ns	69
17	Minimum Write Recovery Time (tWRmin)	15ns	78
18	Minimum /RAS to /CAS Delay Time (tRCDmin)	13.125ns	69
19	Minimum Row Active to Row Active Delay Time (tRRDmin)	6ns	30
20	Minimum Row Precharge Time (tRPmin)	13.125ns	69
21	Upper Nibble for tRAS and tRC	-	11
22	Minmum Active to Precharge Time (tRASmin)	35ns	18
23	Minmum Active to Active/Refresh Time (tRCmin)	48.125ns	81
24	Minmum Refresh Recovery Time (tRFCmin), Least Significant Byte	300ns	60
25	Minmum Refresh Recovery Time (tRFCmin), Most Significant Byte	300ns	09
26	Minmum Internal Write to Read Command Delay Time (tWTmin)	7.5ns	3C
27	Minimum Internal Read to Precharge Command Delay Time (tRTPmin)	7.5ns	3C
28	Upper Nibble for tFAW	30ns	00
29	Minmum Four Active Window Delay Time (tFAWmin)	30ns	F0
30	SDRAM Optional Features	DLL off Mode, RZQ/6, RZQ/7	83
31	SDRAM Thermal and Refresh Options	No ODTs, No ASR	01
32-59	Reserved	-	00

Specifications subject to change without notice, contact your sales representatives for the most update information.

60	Module Nominal Height	30mm	0F					
61	Module Max Thickness	Planar Double Sides	11					
62	Reference Raw Card Used	R/C F	25					
63	Address Mapping from Edge Connector to DRAM	Standard	00					
64-116	Reserved	-	00					
117	Module Manufacturer ID Code, Least Significant Byte	-	01					
118	Module Manufacturer ID Code, Most Significant Byte	-	4F					
119	Module Manufacturing Location	Taipei	54					
120-121	Module Manufacturing Date	-	00					
122-125	Module Serial Number	-	00					
126-127	Cyclical Redundancy Code	-	B8, CC					
128-145	Module Part Number	SQR-SD3M-8G1600SNL	53	51	52	2D	53	44
			33	4D	2D	38	47	31
			36	30	30	53	4E	4C
146-147	Revision Code	-	00					
148-149	DRAM Manufacturer ID Code	By Manufacturer	Variable					
150-175	Manufacturer Specific Data	By Manufacturer	Variable					
176-255	Open for customer use	Undefined	00					

Appendix: Part Number Table

Product	Advantech PN
SGRAM 8G SO-DDR3-1600 LOW VOLTAGE MINUS-GRD SAM	SQR-SD3M-8G1600SNL