

PART NUMBER	REVISION	DESCRIPTION	FEED TYPE
2266515-1	F	FINE CRIMP HEIGHT ADJUST	MECHANICAL
2266515-2	F	FINE CRIMP HEIGHT ADJUST	PNEUMATIC
5-2266515-1	F	SEAL STRIPPER CRIMPER TERMINATING UNIT	MECHANICAL
5-2266515-2	F	SEAL STRIPPER CRIMPER TERMINATING UNIT	PNEUMATIC
7-2266515-1	F	MECHANICAL AND CRIMP TOOLING KIT	MECHANICAL
7-2266515-2	F	PNEUMATIC AND CRIMP TOOLING KIT	PNEUMATIC
7-2266515-7	A	CRIMP TOOLING KIT	-

ATLANTIC VERSION TERMINATOR INTERFACE ADAPTER

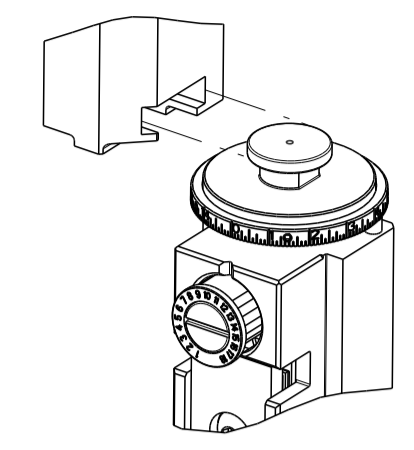

APPLICATOR DATA		
CRIMP	SIZE	TYPE
WIRE	1.78 mm [.070]	F
INSUL	3.30 mm [.130]	O

APPLICATOR INSTRUCTIONS 408-35042

TERMINAL DATA: TE TERMINAL		TE CRIMP SPECIFICATION	
TERMINAL NAME: MCON 1.2 CB			
WIRE STRIP LENGTH		INSULATION DIAMETER RANGE	
3.30-3.90 mm [.130-.154 IN]			
TERMINAL APPLICATION SPECIFICATION	114-18464		
TERMINALS APPLIED			
TE TERMINAL	TE TERMINAL	TE SEAL	CABLE DIAMETER
1418850-1	1418850-3	967067-1	1.4-2.1 [.055-.083]
1418850-2			

WIRE SIZE	CRIMP HEIGHT mm [INCH]	CRIMP HEIGHT REFERENCE SETTING
1.50mm2	1.36+/-0.05 [.054+/-0.002]	4.6
16 AWG	1.31+/-0.05 [.052+/-0.002]	5.0
1.00mm2	1.18+/-0.05 [.046+/-0.002]	6.3
18 AWG	1.11+/-0.05 [.044+/-0.002]	7.2

- 1. RECOMMENDED SPARE PARTS
- 2. REFER TO SUPPLIED INSTRUCTION SHEET FOR CLEANING, LUBRICATION AND STORAGE OF APPLICATOR.
- 3. APPLY PART NUMBER 2-23419-6 LOCTITE TO THREADS OF ITEM 242.
- 4. CRIMP HEIGHT REFERENCE SETTING WAS THE SETTING USED WHEN THE APPLICATOR WAS QUALIFIED AT THE FACTORY. ADJUSTMENT MAY BE NECESSARY WHEN RUNNING APPLICATOR IN THE FIELD.
- 5. APPLY TORO-SEAL IN ALLEN SOCKET TO FILL HOLE AFTER FLAT HD HAS BEEN ADJUSTED TO CORRECT HEIGHT AT QUALIFICATION. APPLY #1-23419-5 LOC-TITE TO THREADS.
- 6. UNLESS SPECIFIED OTHERWISE TORQUE VALUES SHALL BE USED PER DOCUMENT, 101-35000.
- 7. TERMINAL LUBRICANT IS RECOMMENDED.

**\*WARNING**  
 ON INSTALLATION, SET WIRE DISC TO CRIMP HEIGHT REFERENCE SETTING FOR LARGEST WIRE SIZE. CRIMP HEIGHT REFERENCE SETTINGS GREATER THAN THE VALUE SHOWN MAY CAUSE DAMAGE TO THE CRIMP TOOLING. REFER TO THE INSTRUCTION SHEET FOR PROPER SETUP AND ADJUSTMENTS.

LOC	DIST	REVISIONS					
A	66	P	LTN	DESCRIPTION	DATE	OWN	APVD
		C		ECR-19-002820	21FEB2019	FJ	CT
		D		ECR-19-009013	09JUN2019	TB	TE
		E		ECR-19-016584	24OCT2019	FJ	TE
		F		ECR-22-153026	20SEP2022	JWC	TE

-	1	1	1	1	1	1	1803945-4	TONKER	300
-	1	1	1	1	1	1	22278-9	SPRING, COMPRESSION	299
-	2	2	2	2	2	2	4-18032-3	SCR, SET, FLT PNT, M3 X 6.0	298
-	1	1	1	1	1	1	1803944-1	SPACER, TONKER	297
-	-	-	1	1	-	-	2-1803583-1	APPLICATOR BASIC ASSEMBLY, SF	292
-	1	-	1	-	1	-	2119641-1	FEED CAM, AIR FEED	248
-	1	1	1	1	1	1	2119082-4	CAM, SNAIL, INSULATION ADJUSTMENT	244
-	1	1	1	1	1	1	2079764-1	WASHER, WAVE SPRING, CREST-TO-CREST	243
-	1	1	1	1	1	1	2119083-1	RETAINER, INSULATION DIAL	242
-	1	1	1	1	1	1	7-18023-7	SCR, SKT HD CAP M3 X 4.0	241
-	-	1	-	1	-	1	2119580-1	MECHANICAL FEED ASSEMBLY	239
-	1	-	1	-	1	-	2844940-1	AIR FEED MODULE	238
-	-	-	1	1	-	-	993111-1	PIN, SLOTTED SPRING 3.0 X 20.0	177
-	REF	REF	REF	REF	REF	REF	994970-2	COUNTER, MAGNETIC	164
-	1	1	1	1	1	1	2119955-1	ASSY, LUBRICATOR, SIDE FEED	113
-	1	1	1	1	1	1	2844908-1	SCREW, LOCKING	99
-	1	1	1	1	1	1	2844907-1	POST, LOCKING	98
-	1	1	1	1	1	1	455888-4	SPACER, CRIMPER	82
-	1	1	1	1	1	1	1803607-3	DOCUMENTATION PACKAGE	71
-	1	1	1	1	1	1	2119740-1	TAG, IDENTIFICATION	67
-	2	2	2	2	2	2	2168078-1	SCREW, DRIVE, RH, RoHS, 2 x .188	66
-	1	1	1	1	1	1	2168083-2	SCR, SKT HD CAP, RoHS, M4 X 8.0	60
-	1	1	1	1	1	1	5-18022-5	SCR, HEX HD CAP, M4 X 6.0	59
-	1	1	1	1	1	1	985575-3	SCR, FLT SKT HD CAP M3 X 10.0	57
-	1	1	1	1	1	1	1338683-8	FEED PAWL	56
-	4	4	4	4	4	4	2168083-3	SCR, SKT HD CAP, RoHS, M4 X 12.0	54
-	2	2	2	2	2	2	2168083-8	SCR, SKT HD CAP, RoHS, M4 X 16	53
-	1	2	1	2	1	2	18023-9	SCR, SKT HD CAP M4 X 6.0	49
-	-	1	-	1	-	1	2119652-1	FEED CAM, PRE FEED	48
-	-	1	-	1	-	1	2119653-1	FEED CAM, POST FEED	47
-	1	1	-	-	1	1	1803583-9	APPLICATOR BASIC ASSEMBLY, SF	46
-	1	1	1	1	1	1	1803515-1	RAM ASSEMBLY, SF ATLANTIC	44
-	1	1	1	1	1	1	1803602-1	SCR, BHSC, RoHS (M8 X 25)	41
-	1	1	1	1	1	1	1752356-6	SUPPORT, TERMINAL	34
-	2	2	2	2	2	2	2079383-5	SCR, BHSC, RoHS (M4 X 20)	33
-	2	2	2	2	2	2	3-2844962-0	SPACER, CYLINDRICAL, STRIP GUIDE	30
-	1	1	1	1	1	1	2844992-2	ASSEMBLY, STRIP GUIDE	29
-	1	1	1	1	1	1	455888-3	SPACER, CRIMPER	28
-	1	1	1	1	1	1	1320928-2	STRIP GUIDE	24
-	1	1	-	-	1	1	2168083-2	SCR, SKT HD CAP, RoHS, M4 X 8.0	21
-	2	2	1	1	2	2	1-18028-2	WASHER, FLAT, REG M4	20
-	1	1	-	-	1	1	2119533-1	STRIPPER, SIDE FEED	19
-	1	1	1	1	1	1	2119806-1	INSERT, SHEAR	13
-	1	1	1	1	1	1	3-22280-3	SPRING, COMPRESSION	12
-	1	1	1	1	1	1	1-356885-4	STOP, SHEAR	11
-	1	1	1	1	1	1	2119805-1	SHEAR HOLDER, FRONT	10
-	1	1	1	1	1	1	318707-1	FLOATING SHEAR, FRONT	9
1	2	2	1	1	1	1	4-1333203-8	ANVIL, COMBINATION	8
-	1	1	1	1	1	1	1-240641-8	SPACER	7
-	-	-	-	-	-	-	-	-	6
-	1	1	1	1	1	1	2119781-1	DEPRESSOR, SHEAR	5
-	1	1	1	1	1	1	2-238011-1	BLOCK, CRIMPER SPACER	4
1	2	2	1	1	1	1	5-1633965-4	CRIMPER, INSULATION O PREMIUM	3
-	1	1	1	1	1	1	455888-2	SPACER, CRIMPER	2
1	2	2	1	1	1	1	7-456404-2	CRIMPER, WIRE PREMIUM	1

ATLANTIC VERSION  
 Shown on sheets 1 of 4 & 2 of 4  
 (Pacific version shown on sheets 3 of 4 & 4 of 4)

DIMENSIONS: mm		TOLERANCES UNLESS OTHERWISE SPECIFIED:		DRAWING NO		RESTRICTED TO	
0 PLC	±	0.125	±	05FEB2015	NAME		Customer Accessible Production Drawing
1 PLC	±	0.25	±	05FEB2015	OCEAN SIDE FEED APPLICATOR		
2 PLC	±	0.38	±	05FEB2015	SCALE		SHEET 1 OF 4
3 PLC	±	0.51	±	05FEB2015	1:2		
4 PLC	±	0.64	±	05FEB2015	REV		F
ANGLES	±	0.76	±	05FEB2015	SHEET		
FINISH	±	0.89	±	05FEB2015	SCALE		
MATERIAL		FINISH		WEIGHT		SCALE	
						1:2	

LOC	DIST	REVISIONS			
P	LTN	DESCRIPTION	DATE	OWN	APVD
A	66	SEE SHEET 1	-	-	-

# FEED TYPE MECHANICAL

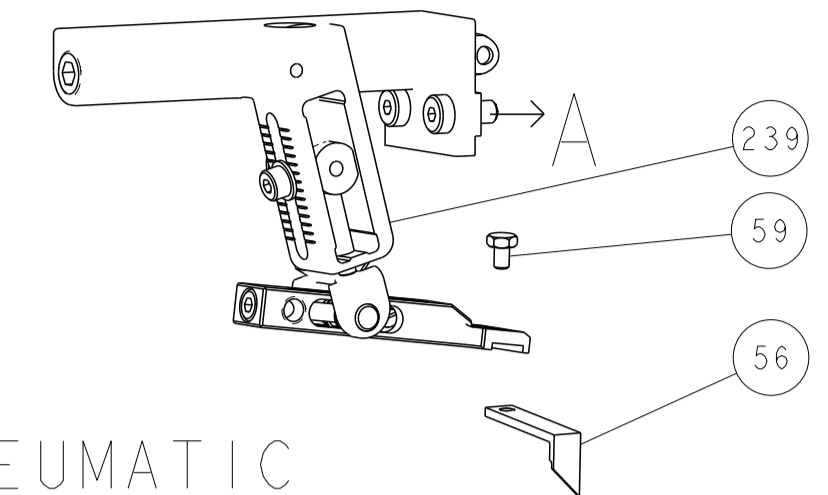

## PNEUMATIC

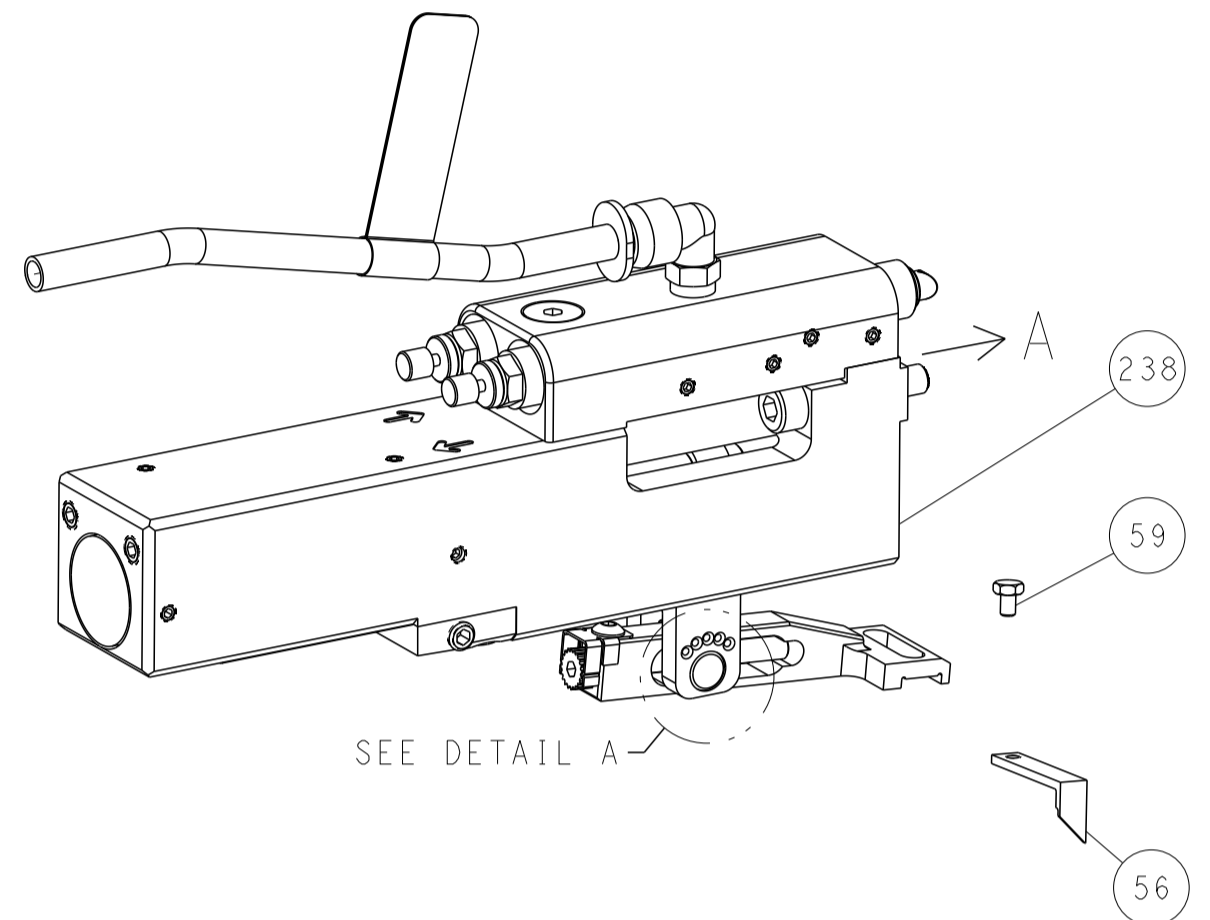

## FEED SPRING SETTING POSITION (SHOWN FROM REAR SIDE)

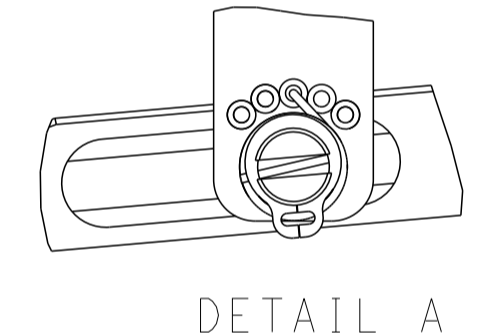

DETAIL A

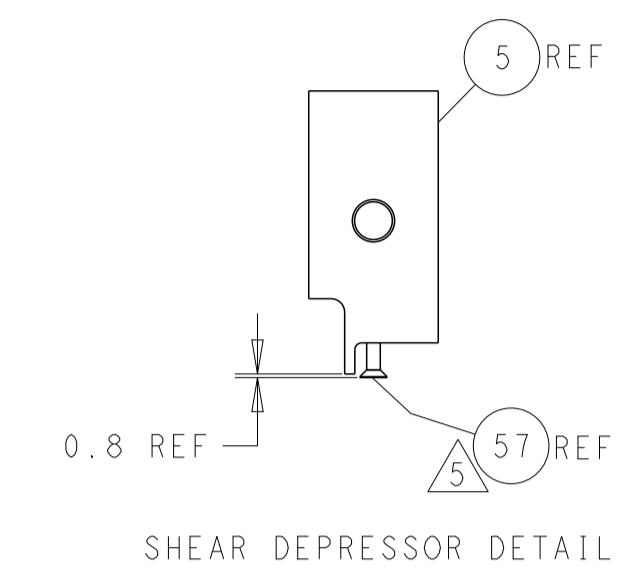
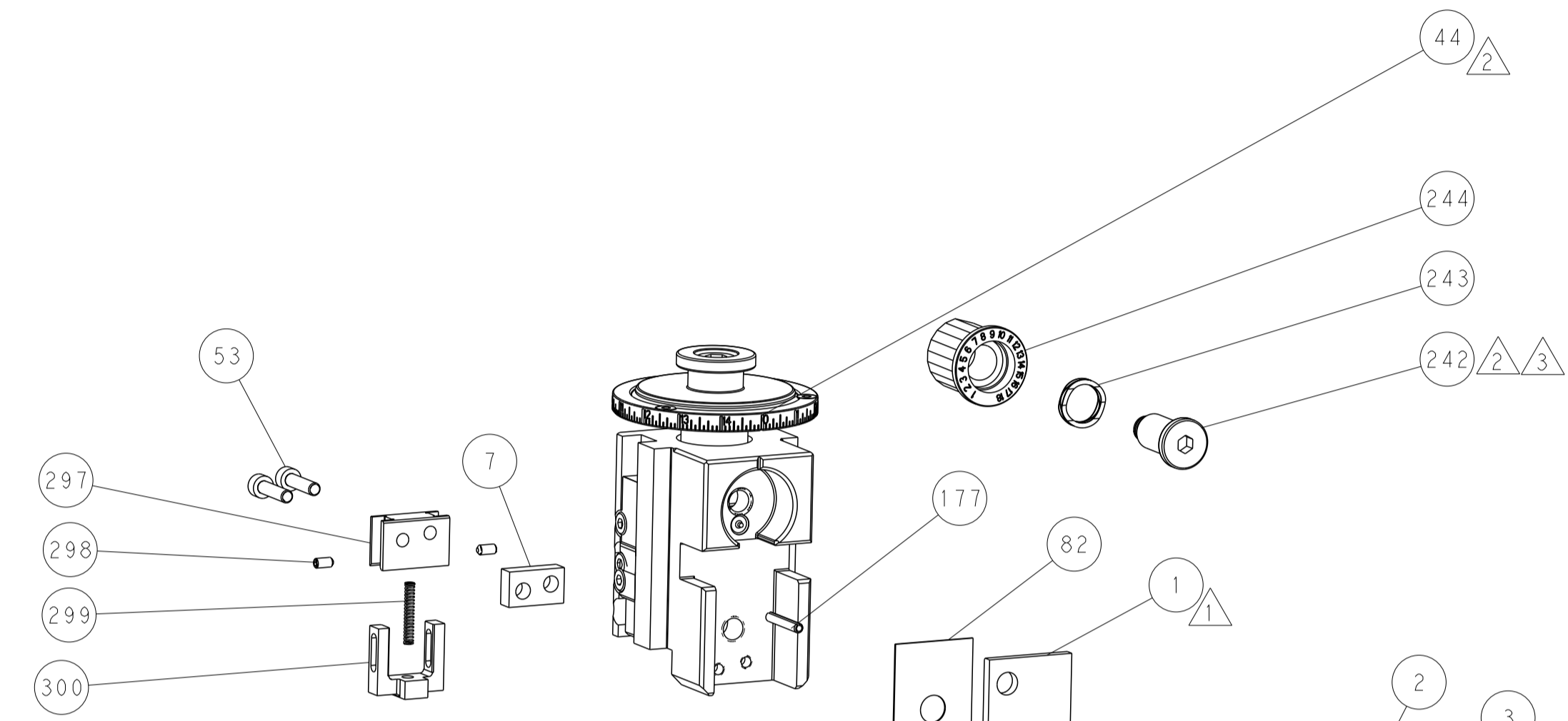

SHEAR DEPRESSOR DETAIL

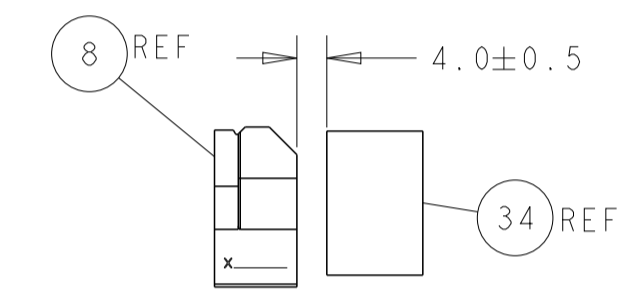

TERMINAL SUPPORT LOCATION

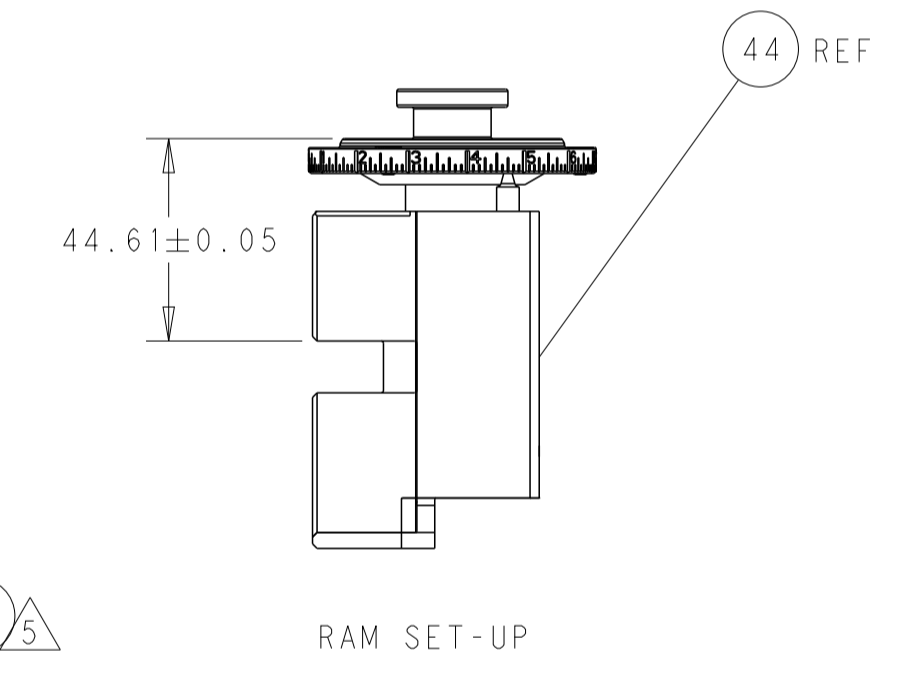

RAM SET-UP

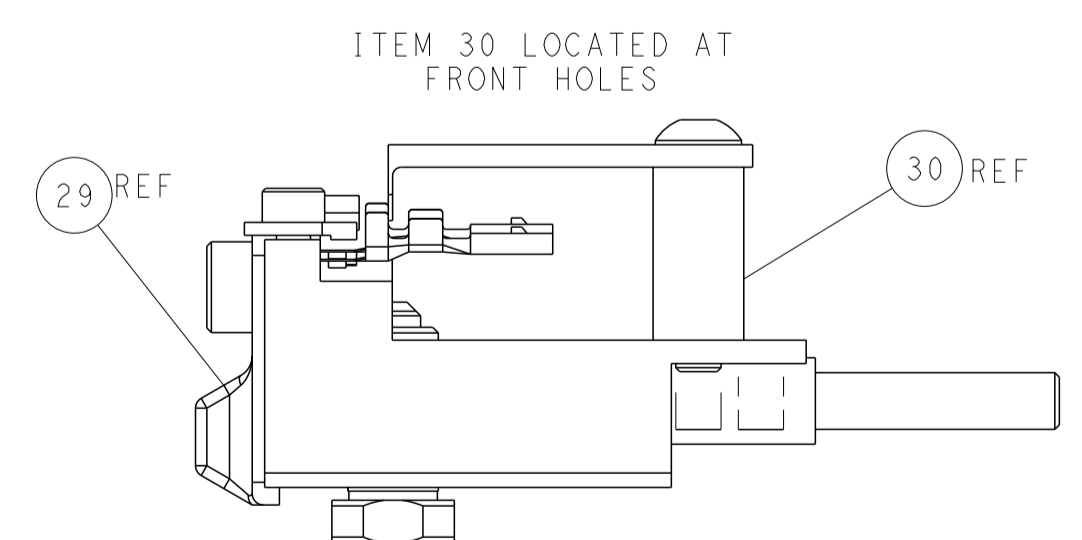

FEED TRACK POSITION GUIDE BY INSULATION BARREL

# CAM POSITIONS

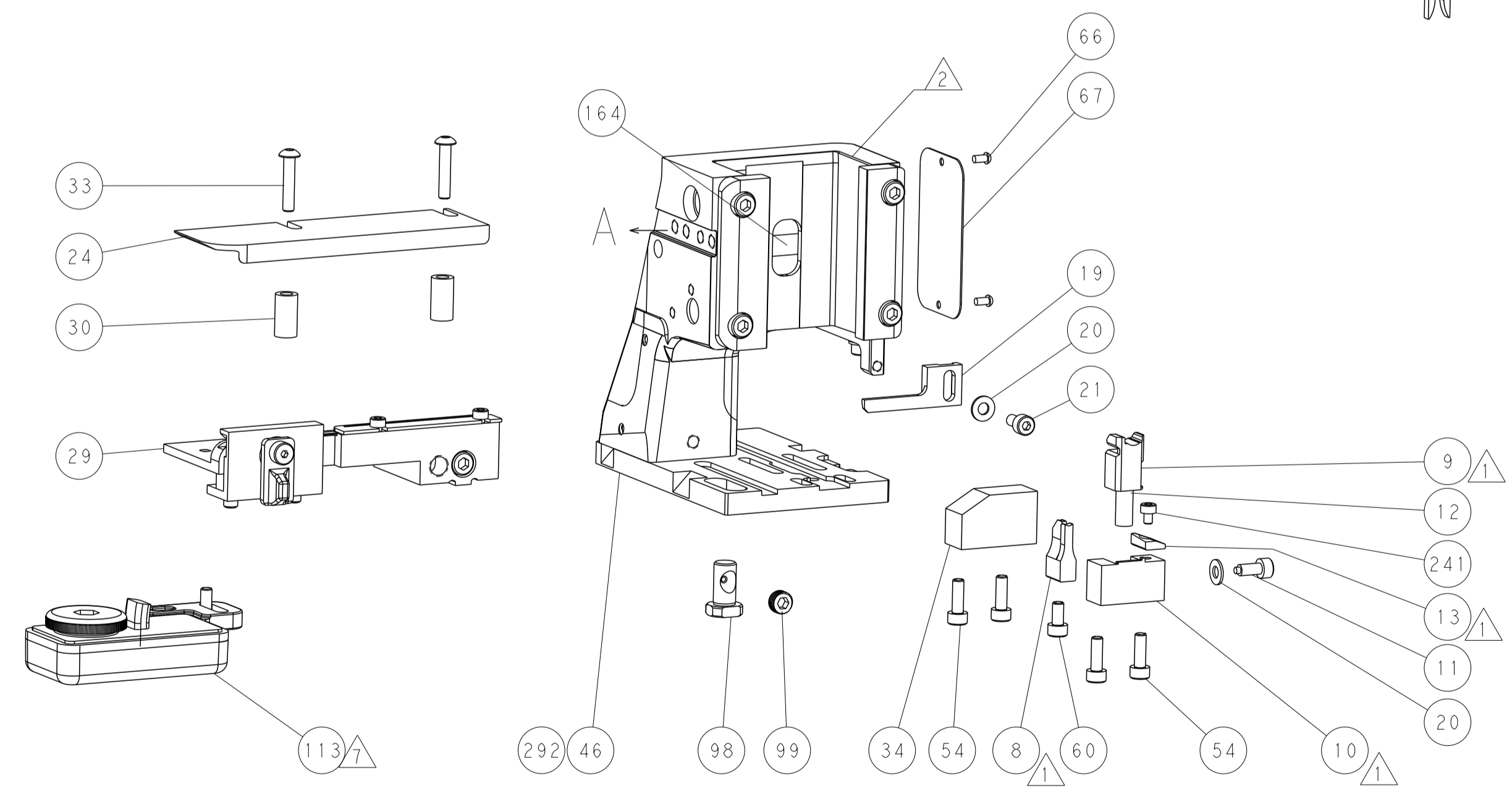
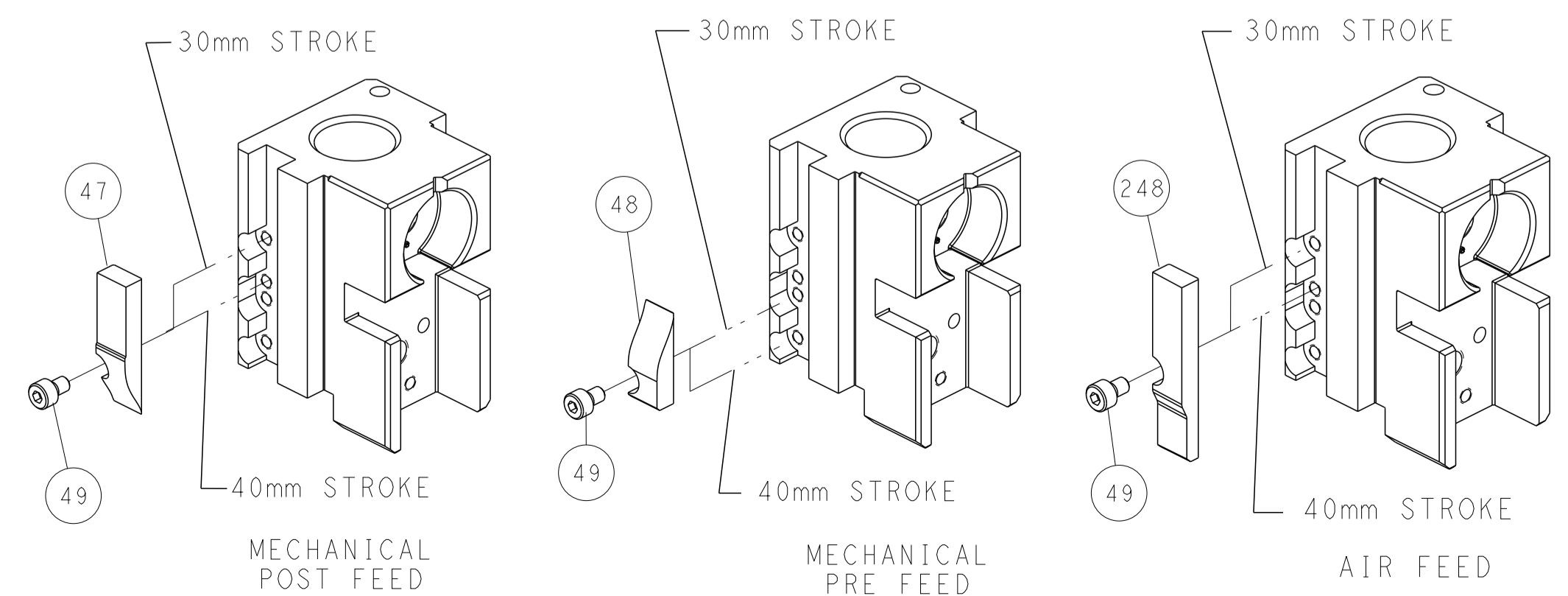

**ATLANTIC VERSION**  
 Shown on sheets 1 of 4 & 2 of 4  
 (Pacific version shown on sheets 3 of 4 & 4 of 4)

DIMENSIONS: mm 		TOLERANCES UNLESS OTHERWISE SPECIFIED: 0 PLC ± 1 PLC ± 2 PLC ± 3 PLC ± 4 PLC ± ANGLES ± FINISH		DWN R.O. WILSON 05FEB2015 CHK K.J. STAKEM 05FEB2015 APVD T.L. ELBIN 05FEB2015 NAME PRODUCT SPEC APPLICATION SPEC WEIGHT SCALE 1:2 SHEET 2 OF 4 REV F		TE Connectivity Harrisburg, PA 17105-3608 Ocean Side Feed Applicator SIZE CAGE CODE DRAWING NO A1 00779 ©=2266515 RESTRICTED TO	
-----------------------	--	---	--	---	--	---	--

PART NUMBER	REVISION	DESCRIPTION	FEED TYPE
2-2266515-1	F	FINE CRIMP HEIGHT ADJUST	MECHANICAL
2-2266515-2	F	FINE CRIMP HEIGHT ADJUST	PNEUMATIC
7-2266515-7	A	CRIMP TOOLING KIT	-

PACIFIC VERSION TERMINATOR  
 INTERFACE ADAPTER



APPLICATOR DATA		
CRIMP	SIZE	TYPE
WIRE	1.78 mm [.070]	F
INSUL	3.30 mm [.130]	O

APPLICATOR INSTRUCTIONS  
 408-35042

TERMINAL DATA: TE TERMINAL		TE CRIMP SPECIFICATION	
TERMINAL NAME: MCON 1.2 CB			
WIRE STRIP LENGTH		INSULATION DIAMETER RANGE	
3.30-3.90 mm [.130-.154 IN]			
TERMINAL APPLICATION SPECIFICATION	114-18464	-	-
TERMINALS APPLIED			
TE TERMINAL	TE TERMINAL	TE SEAL	TE SEAL
1418850-1	1418850-3	967067-1	
1418850-2			

WIRE SIZE	CRIMP HEIGHT mm [INCH]	CRIMP HEIGHT REFERENCE SETTING
1.50mm2	1.36+/-0.05 [.054+/-0.002]	4.6
16 AWG	1.31+/-0.05 [.052+/-0.002]	5.0
1.00mm2	1.18+/-0.05 [.046+/-0.002]	6.3
18 AWG	1.11+/-0.05 [.044+/-0.002]	7.2



- 1 RECOMMENDED SPARE PARTS
- 2 REFER TO SUPPLIED INSTRUCTION SHEET FOR CLEANING, LUBRICATION AND STORAGE OF APPLICATOR.
- 3 APPLY PART NUMBER 2-23419-6 LOCTITE TO THREADS OF ITEM 242.
- 4 CRIMP HEIGHT REFERENCE SETTING WAS THE SETTING USED WHEN THE APPLICATOR WAS QUALIFIED AT THE FACTORY. ADJUSTMENT MAY BE NECESSARY WHEN RUNNING APPLICATOR IN THE FIELD.
- 5 APPLY TORQ-SEAL IN ALLEN SOCKET TO FILL HOLE AFTER FLAT HD HAS BEEN ADJUSTED TO CORRECT HEIGHT AT QUALIFICATION. APPLY #1-23419-5 LOC-TITE TO THREADS.
- 6 UNLESS SPECIFIED OTHERWISE TORQUE VALUES SHALL BE USED PER DOCUMENT, 101-35000.
- 7 TERMINAL LUBRICANT IS RECOMMENDED.

**\*WARNING**  
 ON INSTALLATION, SET WIRE DISC TO CRIMP HEIGHT REFERENCE SETTING FOR LARGEST WIRE SIZE. CRIMP HEIGHT REFERENCE SETTINGS GREATER THAN THE VALUE SHOWN MAY CAUSE DAMAGE TO THE CRIMP TOOLING. REFER TO THE INSTRUCTION SHEET FOR PROPER SETUP AND ADJUSTMENTS.

PACIFIC VERSION  
 Shown on sheets 3 of 4 & 4 of 4  
 (Atlantic version shown on sheets 1 of 4 & 2 of 4)

LOC	DIST	REVISIONS					
A	66	P	LTN	DESCRIPTION	DATE	OWN	APVD
-	-	-	-	SEE SHEET 1	-	-	-

-	1	1	1803945-4	TONKER	300
-	1	1	22278-9	SPRING, COMPRESSION	299
-	2	2	4-18032-3	SCR, SET, FLT PNT, M3 X 6.0	298
-	1	1	1803944-1	SPACER, TONKER	297
-	1	1	2119082-4	CAM, SNAIL, INSULATION ADJUSTMENT	244
-	1	1	2079764-1	WASHER, WAVE SPRING, CREST-TO-CREST	243
-	1	1	2119083-1	RETAINER, INSULATION DIAL	242
-	1	1	7-18023-7	SCR, SKT HD CAP M3 X 4.0	241
-	-	1	2119580-1	MECHANICAL FEED ASSEMBLY	239
-	1	-	2844940-1	AIR FEED MODULE	238
-	REF	REF	994970-2	COUNTER, MAGNETIC	164
-	1	-	2119641-2	FEED CAM, AIR FEED	151
-	1	1	2168083-8	SCR, SKT HD CAP, RoHS, M4 X 16	144
-	4	4	2168083-9	SCR, SKT HD CAP, RoHS, M4 X 20	143
-	-	1	2119653-2	FEED CAM, POST FEED	142
-	1	1	1-1803583-0	APPLICATOR BASIC ASSEMBLY, SF	141
-	1	1	1803516-1	RAM ASSEMBLY, SF PACIFIC	140
-	1	1	2119955-1	ASSY, LUBRICATOR, SIDE FEED	113
-	1	1	2844908-1	SCREW, LOCKING	99
-	1	1	2844907-1	POST, LOCKING	98
-	1	1	455888-4	SPACER, CRIMPER	82
-	1	1	1803607-3	DOCUMENTATION PACKAGE	71
-	1	1	2119740-1	TAG, IDENTIFICATION	67
-	2	2	2168078-1	SCREW, DRIVE, RH, RoHS, 2 x .188	66
-	1	1	5-18022-5	SCR, HEX HD CAP, M4 X 6.0	59
-	1	1	985575-3	SCR, FLT SKT HD CAP M3 X 10.0	57
-	1	1	1338683-8	FEED PAWL	56
-	2	2	2168083-8	SCR, SKT HD CAP, RoHS, M4 X 16	53
-	1	2	18023-9	SCR, SKT HD CAP M4 X 6.0	49
-	-	1	2119652-1	FEED CAM, PRE FEED	48
-	1	1	1803602-1	SCR, BHSC, RoHS (M8 X 25)	41
-	1	1	1752356-6	SUPPORT, TERMINAL	34
-	2	2	2079383-5	SCR, BHSC, RoHS (M4 X 20)	33
-	2	2	3-2844962-0	SPACER, CYLINDRICAL, STRIP GUIDE	30
-	1	1	2844992-2	ASSEMBLY, STRIP GUIDE	29
-	1	1	455888-3	SPACER, CRIMPER	28
-	1	1	1320928-2	STRIP GUIDE	24
-	1	1	2168083-2	SCR, SKT HD CAP, RoHS, M4 X 8.0	21
-	2	2	1-18028-2	WASHER, FLAT, REG M4	20
-	1	1	2119533-1	STRIPPER, SIDE FEED	19
-	1	1	2119806-1	INSERT, SHEAR	13
-	1	1	3-22280-3	SPRING, COMPRESSION	12
-	1	1	1-356885-4	STOP, SHEAR	11
-	1	1	2119805-1	SHEAR HOLDER, FRONT	10
-	1	1	318707-1	FLOATING SHEAR, FRONT	9
1	1	1	4-1333203-8	ANVIL, COMBINATION	8
-	1	1	1-240641-8	SPACER	7
-	-	-	-	-	6
-	1	1	2119781-1	DEPRESSOR, SHEAR	5
-	1	1	2-238011-1	BLOCK, CRIMPER SPACER	4
1	1	1	5-1633965-4	CRIMPER, INSULATION O PREMIUM	3
-	1	1	455888-2	SPACER, CRIMPER	2
1	1	1	7-456404-2	CRIMPER, WIRE PREMIUM	1

DIMENSIONS:		TOLERANCES UNLESS OTHERWISE SPECIFIED:		MATERIAL:		FINISH:	
mm	0 PLC ±	1 PLC ±	2 PLC ±	3 PLC ±	4 PLC ±	ANGLES ±	FINISH

ITEM NO	PART NO	DESCRIPTION
-77	-22	-21

OWN: R.O. WILSON 05FEB2015	CHK: K.J. STARKEM 05FEB2015	APVD: T.L. ELBIN 05FEB2015
NAME: Ocean Side Feed Applicator		
SIZE: A1	CAGE CODE: 00779	DRAWING NO: C=2266515
Customer Accessible Production Drawing		
SCALE: 1:2	SHEET: 3	OF: 4
REV: F		

LOC	DIST	REVISIONS					
A	66	P	LTN	DESCRIPTION	DATE	DMN	APVD
-	-	-	-	SEE SHEET 1	-	-	-

# FEED TYPE MECHANICAL

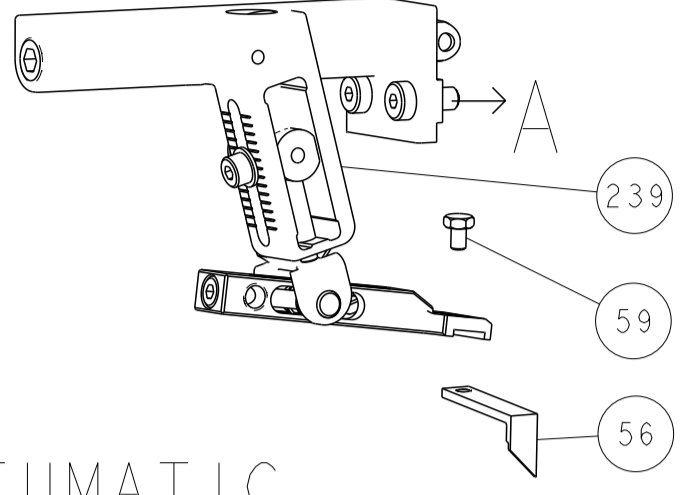

## PNEUMATIC

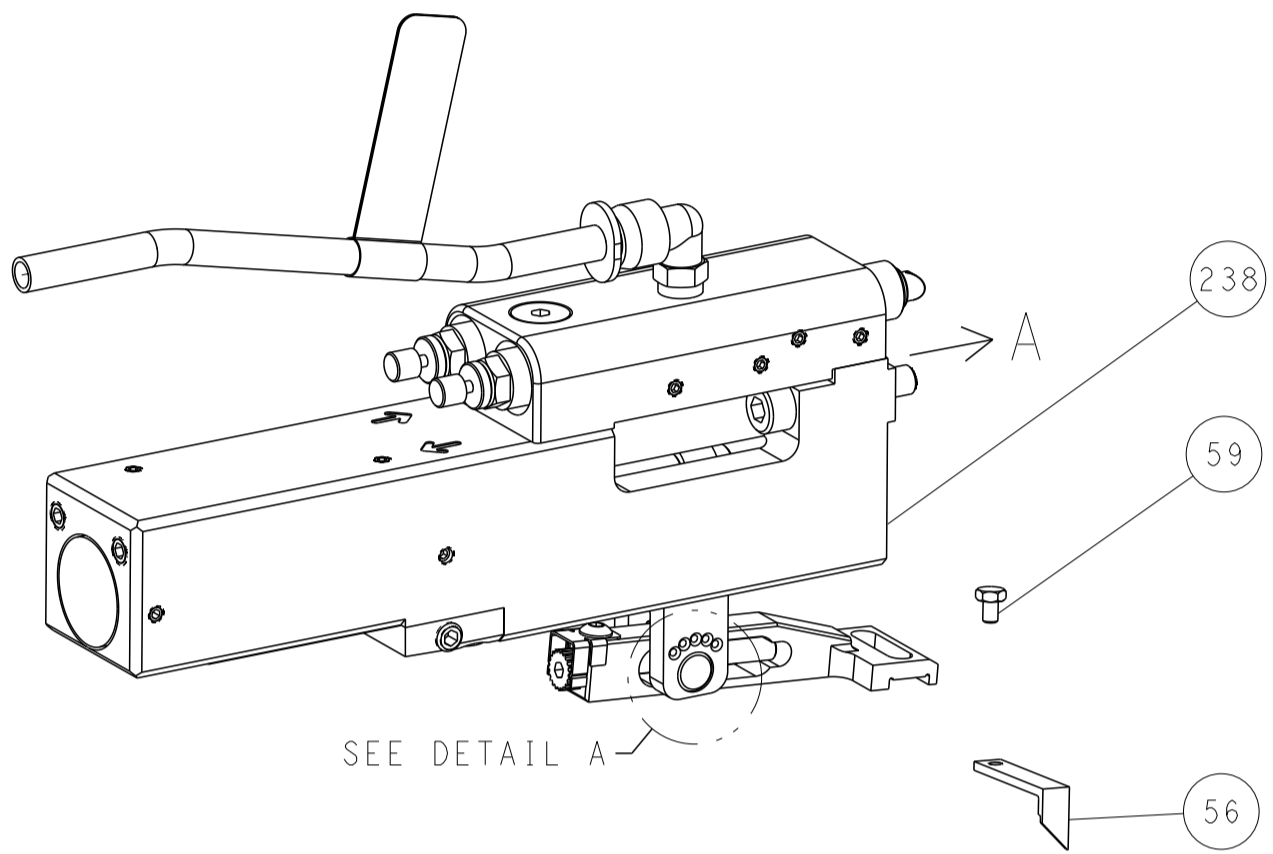

### FEED SPRING SETTING POSITION (SHOWN FROM REAR SIDE)

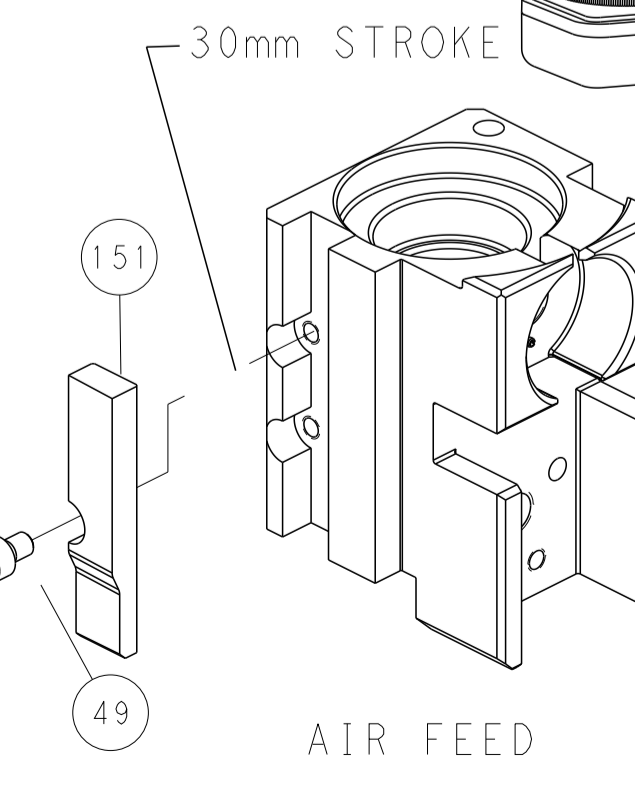
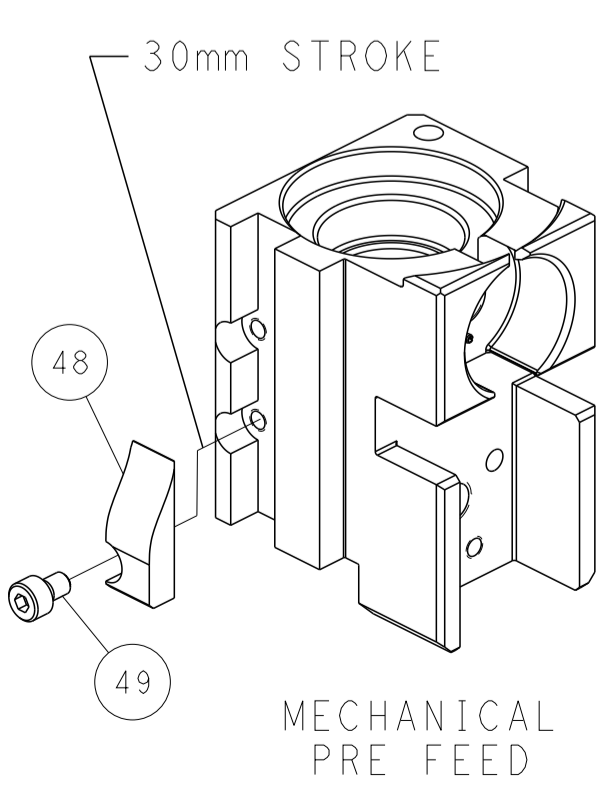
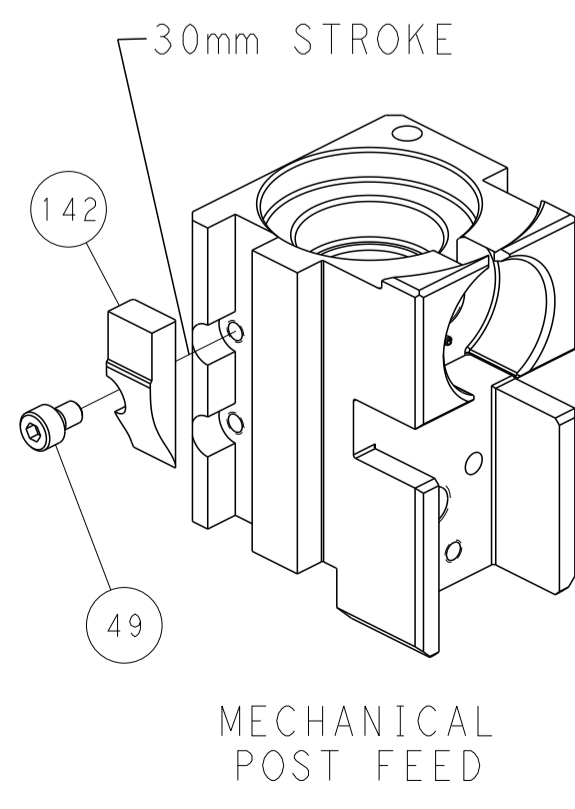
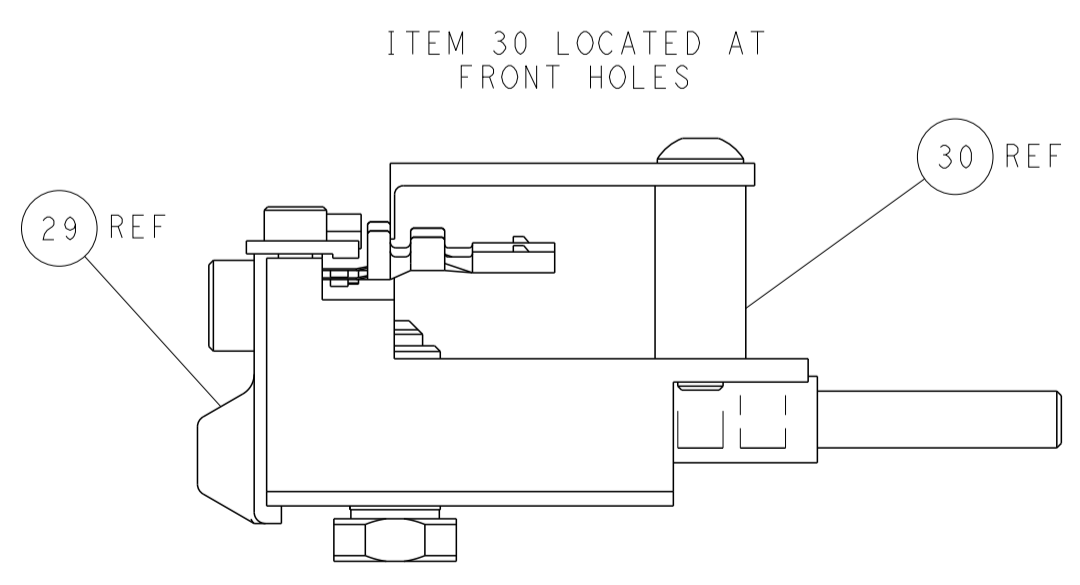
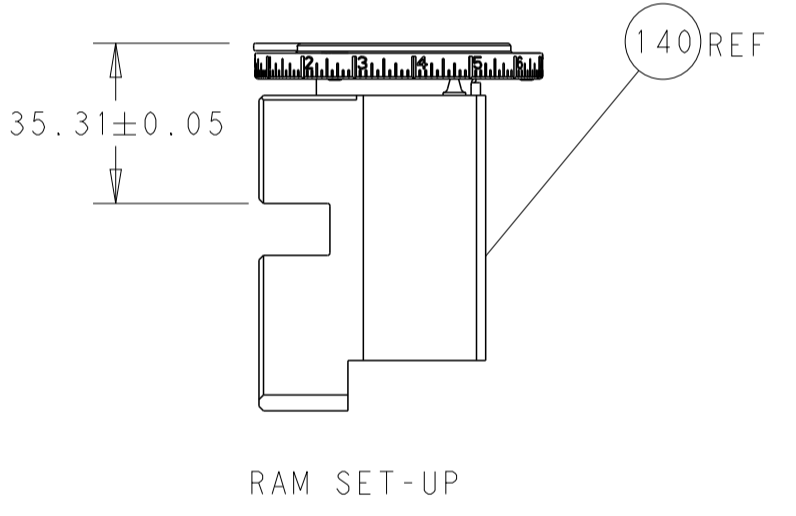
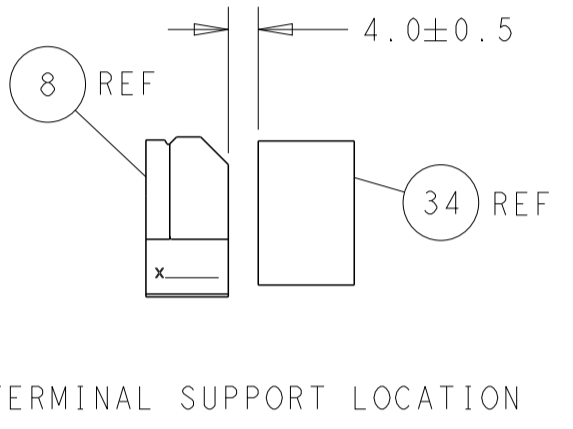
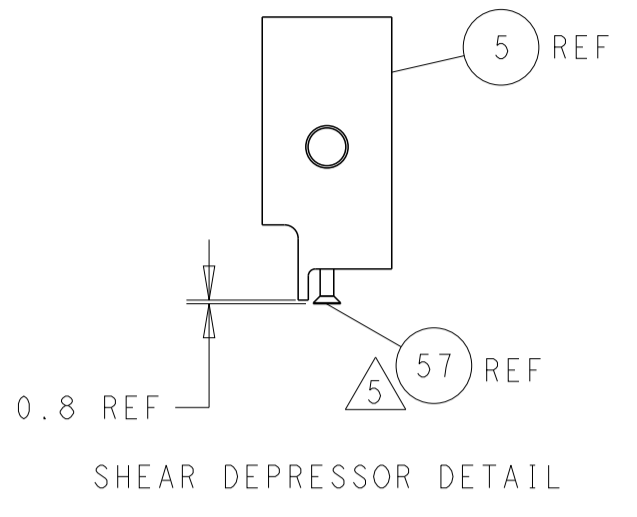
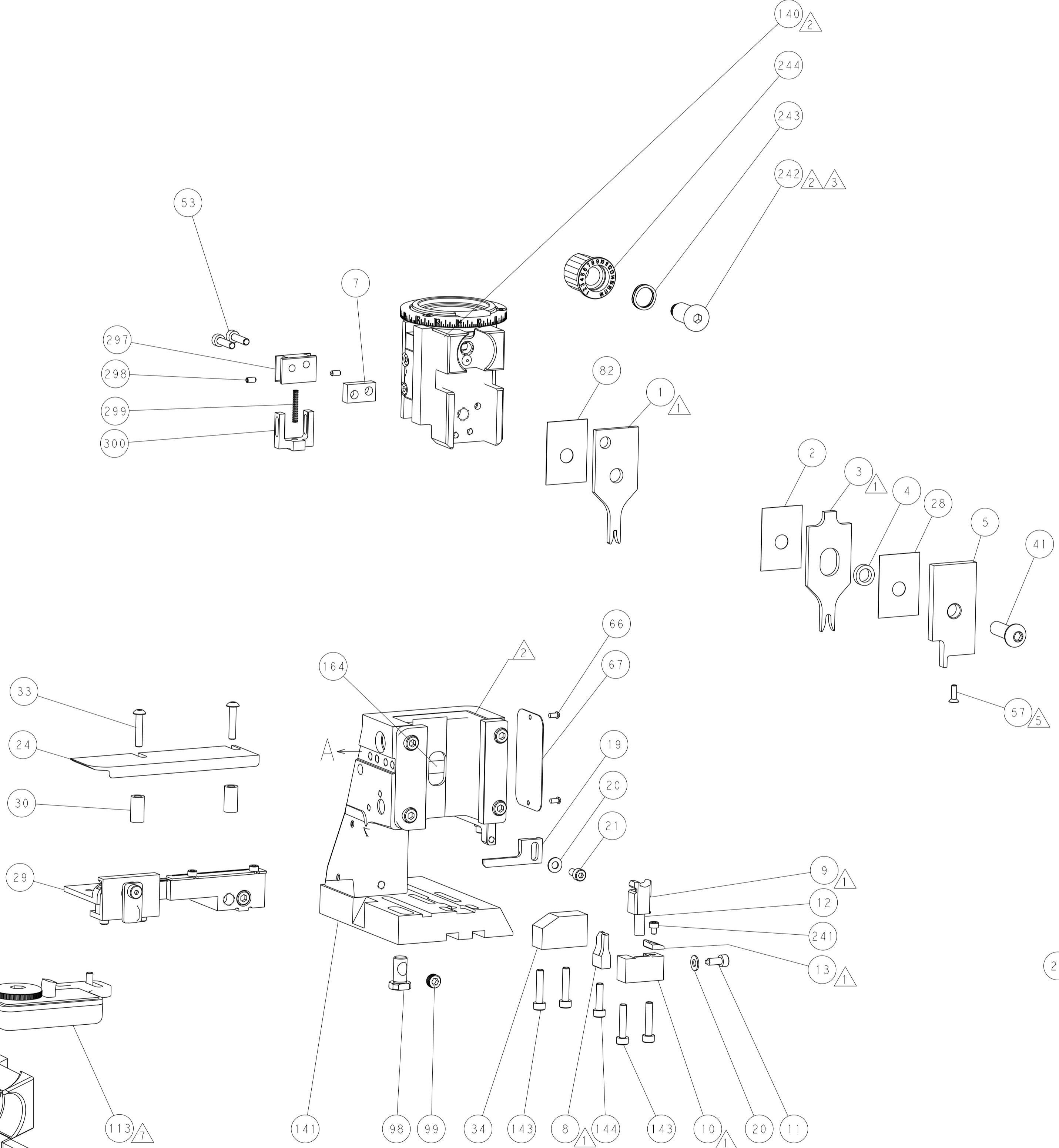
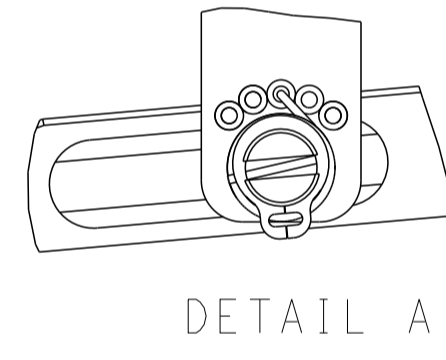

**PACIFIC VERSION**  
 Shown on sheets 3 of 4 & 4 of 4  
 (Atlantic version shown on sheets 1 of 4 & 2 of 4)

DIMENSIONS:		TOLERANCES UNLESS OTHERWISE SPECIFIED:		DWG: R.O. WILSON 05FEB2015		TE Connectivity	
mm	0 PLC ±	1 PLC ±	2 PLC ±	3 PLC ±	4 PLC ±	5 PLC ±	Harrisburg, PA 17105-3608
ANGLES	FINISH	WEIGHT	SCALE	APVD: T.L. ELBIN 05FEB2015	NAME	SIZE	CAGE CODE
			1:2	PRODUCT SPEC	Ocean Side Feed Applicator	00779	2266515
MATERIAL				APPLICATION SPEC			
				RESTRICTED TO			
				Customer Accessible Production Drawing			