

# JACK SCREW STANDOFF

## JSO SERIES



**JSO**  
Use With:  
SEAX, SEAX8, LPAX, LSHM

**JSO**

**BOARD  
STACKER**

**LEAD STYLE**

**PLATING  
OPTION**

### SPECIFICATIONS

**Material:**  
Stainless Steel  
**Locking Compound:**  
Nylon

Specify  
**BOARD STACKER**  
from chart

**-01**  
= Press-In  
(-0415, -0515, -0715, -0815 only)

**-03**  
= Male Thread  
(-0815, -1015, -1115, -1615 only)

**-L**  
= Locking compound  
(Not available with -01 lead style,  
Required for -03 lead style)

BOARD STACKER	A	B	BOARD STACK HEIGHT
-0415	(4.15) .163	(2.50) .098	4 mm
-0515	(5.15) .203	(3.50) .138	5 mm
-0715	(7.15) .281	(5.50) .217	7 mm
-0815	(8.15) .321	(6.50) .256	8 mm
-1015	(10.15) .400	(8.50) .335	10 mm
-1115	(11.15) .439	(9.50) .374	11 mm
-1615	(16.15) .636	(14.50) .571	16 mm

### ALSO AVAILABLE MOQ Required

Other heights  
Locking compound removed

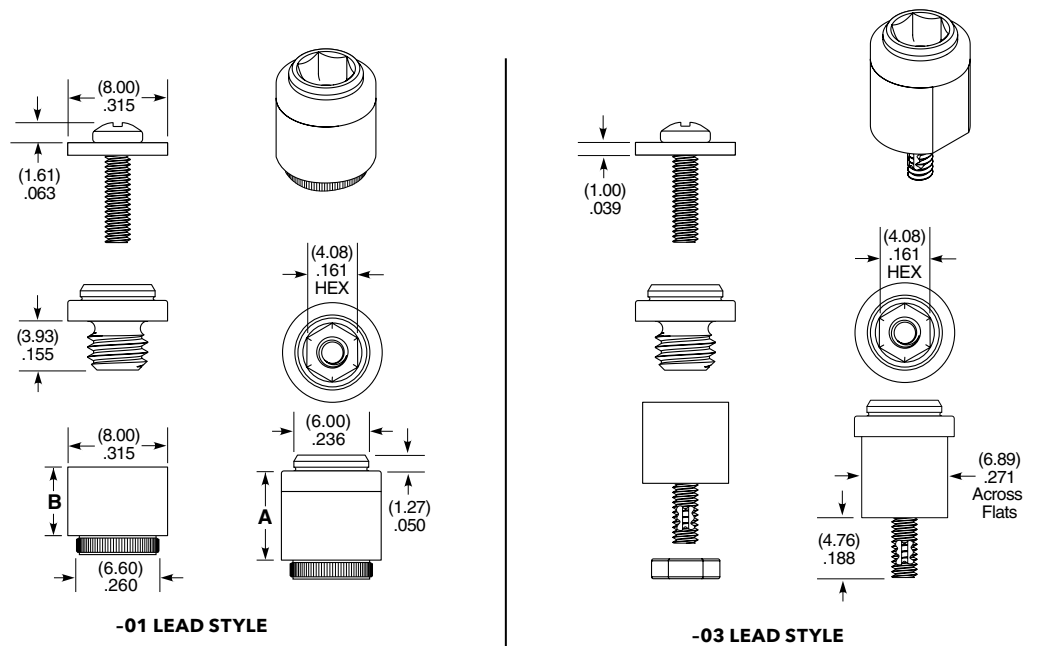

**Note:**  
Some sizes, styles and  
options are non-standard,  
non-returnable.

Components are to be packaged in separate bags unassembled.

## APPLICATION

