

THIS DRAWING CONTAINS INFORMATION PROPRIETARY TO RF INDUSTRIES,
 ANY UNAUTHORIZED USE OF THIS DRAWING IS EXPRESSLY PROHIBITED
 WITHOUT WRITTEN PERMISSION FROM RF INDUSTRIES.
 ANY VIOLATION IS PUNISHABLE UNDER U.S. COPYRIGHT LAWS.

ALL DIMENSIONS ARE REFERENCE ONLY

PART NO.		RSA-3000-1		
REV	DESCRIPTION	DWN	DATE	APPROVED
-	ENGINEERING RELEASE	CZS	01/28/00	JDMc
A	ADD ELECTRICAL SPECS	CZS	10/31/01	JDMc
B	ADDED SOLDER ONLY NOTE & CRIMP DIE CALL OUT	CZS	08/08/06	JDMc

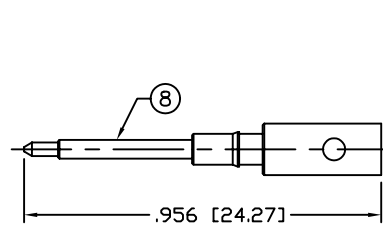
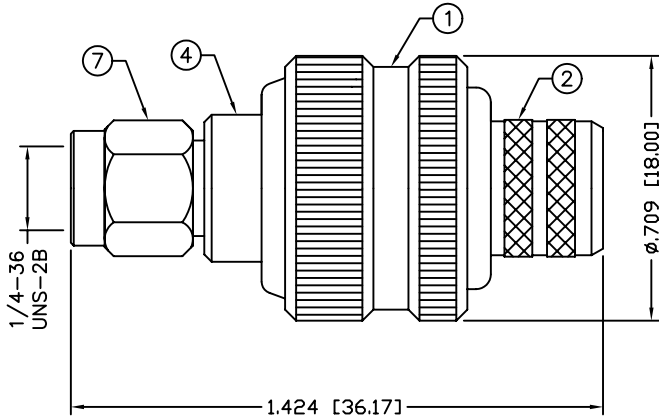

RECOMMENDED CRIMP DIE SIZE: .118"/.128"
 "SOLDER ONLY" FOR RG-8/U TYPE CABLE

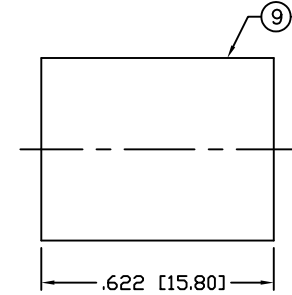

RECOMMENDED CRIMP DIE SIZE: .429"

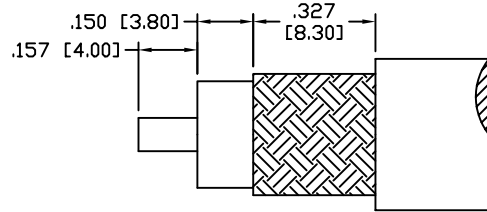

RECOMMENDED STRIPPING DIMENSIONS

SPECIFICATIONS:

IMPEDANCE: 50 Ohms
 FREQUENCY RANGE: 0-12.4 GHz
 INSERTION LOSS(dB): $0.03 \times \sqrt{f(\text{GHz})}$
 VSWR: 1.3 MAX.
 WORKING VOLTAGE: 500 V rms Max. @ Sea Level
 INSULATION RESISTANCE: 5k M Ohms min.
 TEMPERATURE RANGE: -65°C TO 85°C
 FOR BELDEN 8214, 9913, 9913F, 9914, RG-8/U TYPE,
 CAROL C1180, TIMES AA-5886 & LMR-400 CABLE

1	BODY	1	BRASS	NICKEL, 100μ"
2	FERRULE STUD	1	BRASS	NICKEL, 100μ"
3	INSULATOR	1	PTFE	---
4	SMA BODY	1	BRASS	NICKEL, 100μ"
5	RETAINING RING	1	Be. Cu.	---
6	GASKET	1	SILICONE	---
7	SHELL	1	BRASS	NICKEL, 100μ"
8	PIN	1	BRASS	GOLD, 50μ"
9	FERRULE	1	BRASS	NICKEL, 100μ"
10				
11				
12				
13				
14				
#	DESCRIPTION	QTY	MATERIAL	FINISH

008974	
DRAWN	
C. ZUNIGA	08/08/06
CHECKED	
ORJ DRAWN	
C. ZUNIGA	03/14/01
APPROVALS	DATE

UNLESS OTHERWISE SPECIFIED:
 1. REMOVE ALL BURRS
 2. BREAK ALL CORNERS & EDGES .005 R. MAX.
 3. CHAMFER 1ST & LAST THREADS 45°
 4. SURFACE ROUGHNESS 63 FINISH MIL-STD-10
 5. DIAMETERS ON COMMON CENTERS TO BE CONCENTRIC WITHIN .002 T.I.R.
 6. ALL DIMENSIONS ARE AFTER PLATING.

DIMENSIONS ARE IN INCHES AND [MILLIMETERS]
 UNLESS OTHERWISE NOTED TOLERANCES ARE:
 DECIMALS .xxx±.003 [.08] DIAMETER .xxx±.001 [.03]
 .xx±.005 [-.13] .xx±.003 [.08]

7610 MIRAMAR RD
 SAN DIEGO, CA 92126
 (858) 549-6340
 (858) 549-6345 FAX

RF connectors
 DIVISION OF RF INDUSTRIES, LTD.

SMA PLUG, CRIMP

SIZE	CABLE GROUP	DWG NO.	REV
A	I	RSA-3000-1	B
SCALE: NTS		CAD FILE OUTLINE	SHEET 1 OF 1