

# Quad FET Driver

## FEATURES

- High Peak Output Current  
Each Output – 1.5A Source,  
2.0A Sink
- Wide Operating Voltage  
Range 4.5V to 18V
- Thermal Shutdown
- CMOS Compatible Inputs
- Outputs Are Active Low  
for Undervoltage Lockout  
Condition

## DESCRIPTION

The UCC3776 is a four output BCDMOS buffer/driver designed to drive highly capacitive loads such as power MOSFET gates at high speeds. The device can be configured as either an inverting or non-inverting driver via the POL pin. The outputs are enabled by ENBL. When disabled, all outputs are active low. The device incorporates thermal shutdown with hysteresis for stability. The device also includes an undervoltage lockout circuit (UVLO) with hysteresis which disables the outputs when VDD is below a preset threshold. The outputs are held low during undervoltage lockout, even in the absence of VDD power to the device. This helps prevent MOSFET turn-on due to capacitive current through the gate-drain capacitance of the power MOSFET in the presence of high dV/dts. The logic input thresholds are compatible with standard 5V HCMOS logic.

## BLOCK DIAGRAM

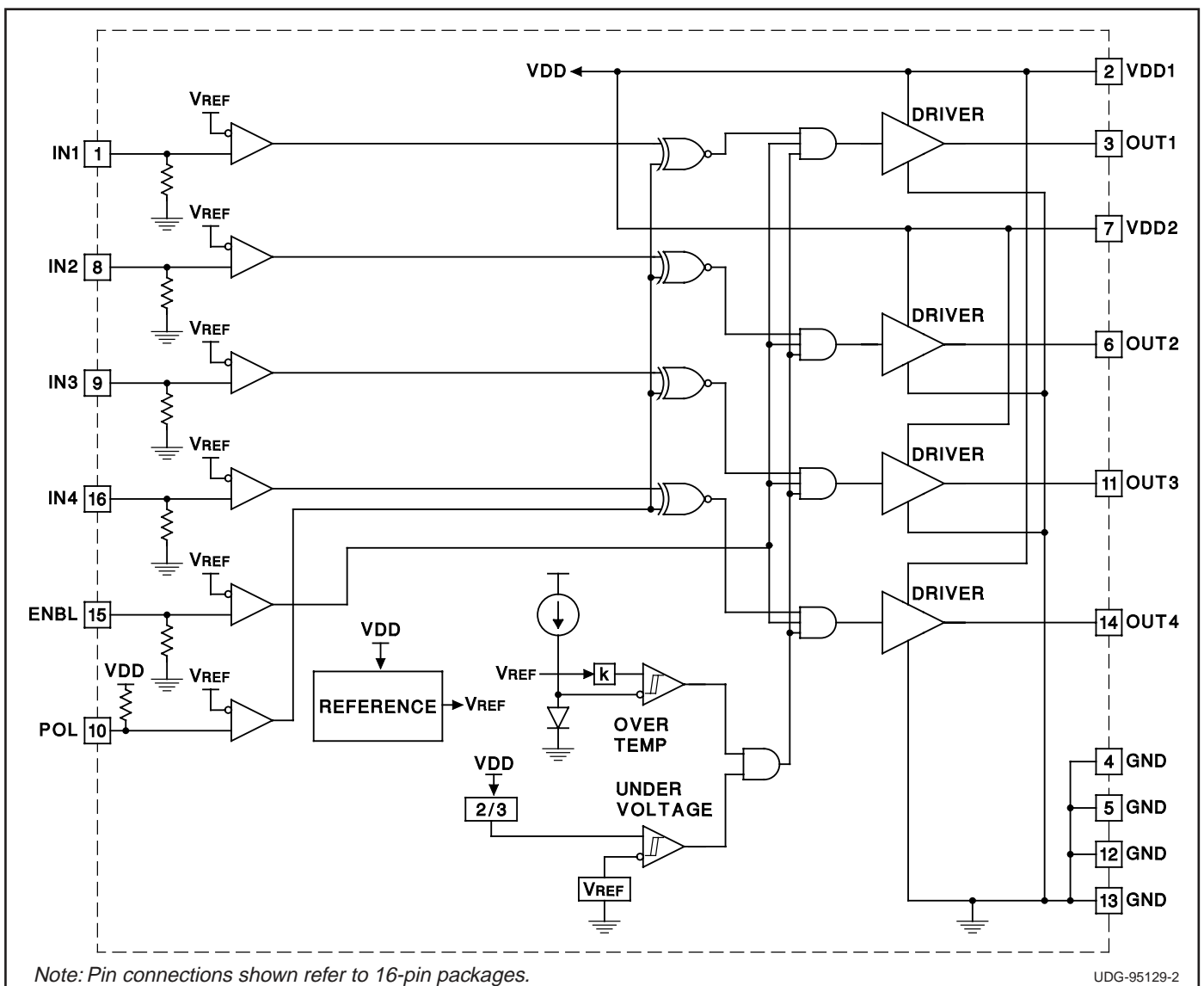

UDG-95129-2

**ABSOLUTE MAXIMUM RATINGS**

Input Supply Voltage, VDD1, VDD2 ..... .20V  
 Maximum DC Voltage Difference, VDD1 vs. VDD2 ..... .100mV  
 Logic Input, IN1, IN4, ENBL  
 Maximum forced voltage ..... -0.3 to VDD1 + 0.3V  
 Logic Inputs, IN2, IN3, POL  
 Maximum forced voltage ..... -0.3 to VDD2 + 0.3V  
 Latch-up Protection withstand Reverse Current  
 IREV, OUT1, OUT2, OUT3, OUT4 ..... .500mA  
 Power Outputs, OUT1, OUT2, OUT3, OUT4  
 Maximum pulsed current (10% duty max, 10µsec max pulse width) ..... .3A  
 Storage Temperature ..... -65°C to +150°C  
 Operating Junction Temperature ..... -55°C to +150°C  
 Lead Temperature (Soldering, 10 Seconds) ..... .300°C  
*All currents are positive into, negative out of the specified terminal. Consult Packaging Section of Databook for thermal limitations and considerations of packages.*

**CONNECTION DIAGRAMS**

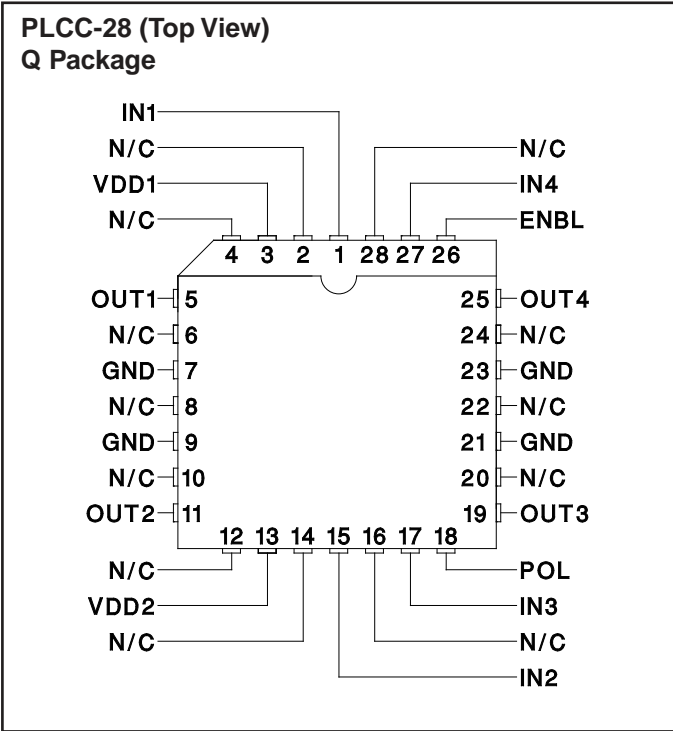
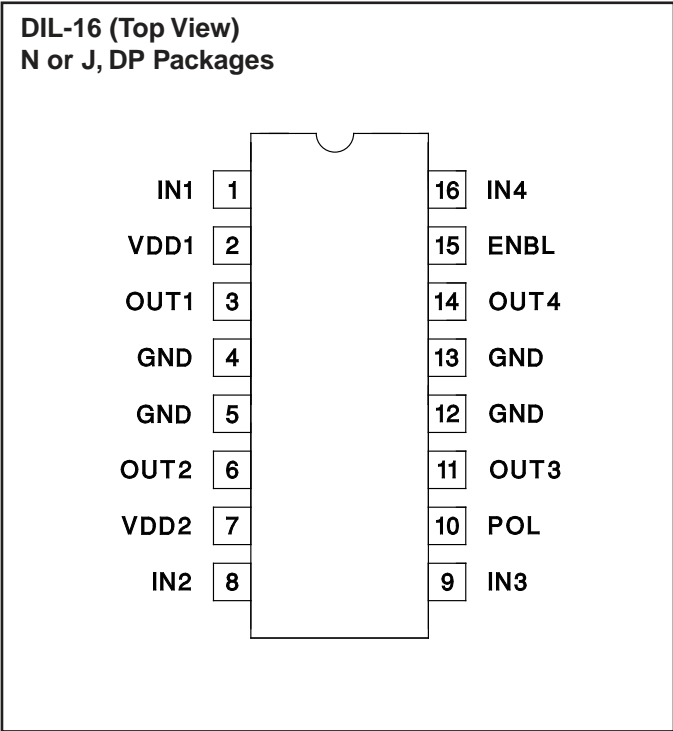

**ELECTRICAL CHARACTERISTICS** Unless otherwise stated these specifications apply for TA = -55°C to +125°C for UCC1776; -40°C to +85°C for UCC2776; 0°C to +70°C for UCC3776; VPOL = 5V, VENBL = 5V, 4.5V < VDD < 18V, TJ = TA.

PARAMETER	TEST CONDITIONS	MIN	TYP	MAX	UNITS
<b>Input Section</b>					
VIH, Logic 1 Input Voltage		3			V
VIL, Logic 0 Input Voltage				2	V
IINn, Input Current	VINn = 5V			30	µA
	VINn = 0V	-1		+1	µA
ENBL Input Current	VENBL = 5V			30	µA
	VENBL = 0V	-1		+1	µA
POL Input Current	VPOL = 5V	-1		+1	µA
	VPOL = 0V	-30			µA

**ELECTRICAL CHARACTERISTICS (cont.)** Unless otherwise stated these specifications apply for  $T_A = -55^{\circ}\text{C}$  to  $+125^{\circ}\text{C}$  for UCC1776;  $-40^{\circ}\text{C}$  to  $+85^{\circ}\text{C}$  for UCC2776;  $0^{\circ}\text{C}$  to  $+70^{\circ}\text{C}$  for UCC3776;  $V_{\text{POL}} = 5\text{V}$ ,  $V_{\text{ENBL}} = 5\text{V}$ ,  $4.5\text{V} < V_{\text{DD}} < 18\text{V}$ ,  $T_J = T_A$ .

PARAMETER	TEST CONDITIONS	MIN	TYP	MAX	UNITS
<b>Output Section</b>					
VOH, High Output Voltage	$I_{\text{OUTn}} = -10\text{mA}$ , $V_{\text{DD1}} = V_{\text{DD2}} = 12\text{V}$ , $V_{\text{INn}} = 5\text{V}$	$V_{\text{DD}} - 1.0$			V
VOL, Low Output Voltage	$I_{\text{OUTn}} = 10\text{mA}$ , $V_{\text{DD1}} = V_{\text{DD2}} = 12\text{V}$ , $V_{\text{INn}} = 0\text{V}$			0.15	V
Output Resistance	$I_{\text{OUTn}} = 10\text{mA}$ , $V_{\text{DD1}} = V_{\text{DD2}} = 12\text{V}$ , $V_{\text{INn}} = 0\text{V}$		6		$\Omega$
Output High Peak Current	$V_{\text{DD1}} = V_{\text{DD2}} = 12\text{V}$ , $I_{\text{OUTn}} = 5\text{V}$ , $V_{\text{INn}} = 5\text{V}$ , $T_J = 25^{\circ}\text{C}$ (Note 1)		-1.5		A
Output Low Peak Current	$V_{\text{DD1}} = V_{\text{DD2}} = 12\text{V}$ , $I_{\text{OUTn}} = 5\text{V}$ , $V_{\text{INn}} = 0\text{V}$ , $T_J = 25^{\circ}\text{C}$ (Note 1)		2.0		A
UVLO Output Pull-down Voltage	$V_{\text{DD1}} = V_{\text{DD2}} = 3\text{V}$ , $I_{\text{OUTn}} = -10\text{mA}$		0.8	1.5	V
<b>Switching Time Section</b>					
Output Rise Time	$C_{\text{OUTn}} = 1\text{nF}$ , $V_{\text{OUTn}} = 1\text{V}$ to $9\text{V}$ , $V_{\text{DD1}} = V_{\text{DD2}} = 12\text{V}$		25	50	nsec
Output Fall Time	$C_{\text{OUTn}} = 1\text{nF}$ , $V_{\text{OUTn}} = 9\text{V}$ to $1\text{V}$ , $V_{\text{DD1}} = V_{\text{DD2}} = 12\text{V}$		10	50	nsec
IN→OUT Delay Time (Rising Output)	$V_{\text{INn}} = 2.5\text{V}$ , $V_{\text{OUTn}} = 0.1 \cdot V_{\text{DD}}$ , $V_{\text{DD1}} = V_{\text{DD2}} = 12$ , $C_{\text{OUTn}} = 0\text{nF}$		40	100	nsec
IN→OUT Delay Time (Falling Output)	$V_{\text{INn}} = 2.5\text{V}$ , $V_{\text{OUTn}} = 0.9 \cdot V_{\text{DD}}$ , $V_{\text{DD1}} = V_{\text{DD2}} = 12\text{V}$ , $C_{\text{OUTn}} = 0\text{nF}$		50	100	nsec
<b>Power Supply Section</b>					
Power Supply Current	$V_{\text{IN1-IN4}} = 0\text{V}$ , $V_{\text{ENBL}} = 0\text{V}$ , $V_{\text{DD1}} = V_{\text{DD2}} = 12\text{V}$			2	mA
UVLO Threshold				4.5	V
UVLO Hysteresis			0.5		V

Note 1: Guaranteed by design. Not 100% tested in production.

## PIN DESCRIPTIONS

**ENBL:** Logic level input to enable the drivers. When ENBL is low, the drivers outputs will be at GND potential, regardless of the status of POL. The input threshold is designed to be 5 volt CMOS compatible, independent of the VDD voltage used on the device. There is a slight hysteresis in the input circuit to help reduce sensitivity to noise on the input signal or input ground.

**GND:** Ground for the device, the supply return for the VDDs. There are four GND pads on the device.

**IN1 - IN4:** Inputs to each driver (1-4). The input threshold is designed to be 5 volt CMOS compatible, independent of the VDD voltage used on the device. There is a slight hysteresis in the input circuit to help reduce sensitivity to noise.

**OUT1 - OUT4:** Outputs to each driver (1-4). The outputs are totem pole DMOS circuits. In the absence of VDD on the device, the outputs will stay off, even with a capacitive displacement current into the output node.

**POL:** Polarity selection for the drivers. A logic 0 selects inverting operation. A logic 1 selects non-inverting operation. The input threshold is designed to be 5 volt CMOS compatible, independent of the VDD voltage used on the device. There is a slight hysteresis in the input circuit to help reduce sensitivity to noise.

**VDD1:** Supply Voltage for drivers 1 and 4. Tied internally to VDD2.

**VDD2:** Supply Voltage for drivers 2 and 3. Tied internally to VDD1.

## APPLICATION INFORMATION

Figure 1 depicts a block diagram of the UCC3776 Quad FET Driver. Four high current, high speed gate drivers with CMOS compatible input stages are provided. Polarity select and enable inputs provide circuit integra-

tion flexibility, while power packaging and high speed drive circuitry allow for driving high power MOSFET gates in high speed applications.

APPLICATION INFORMATION (cont.)

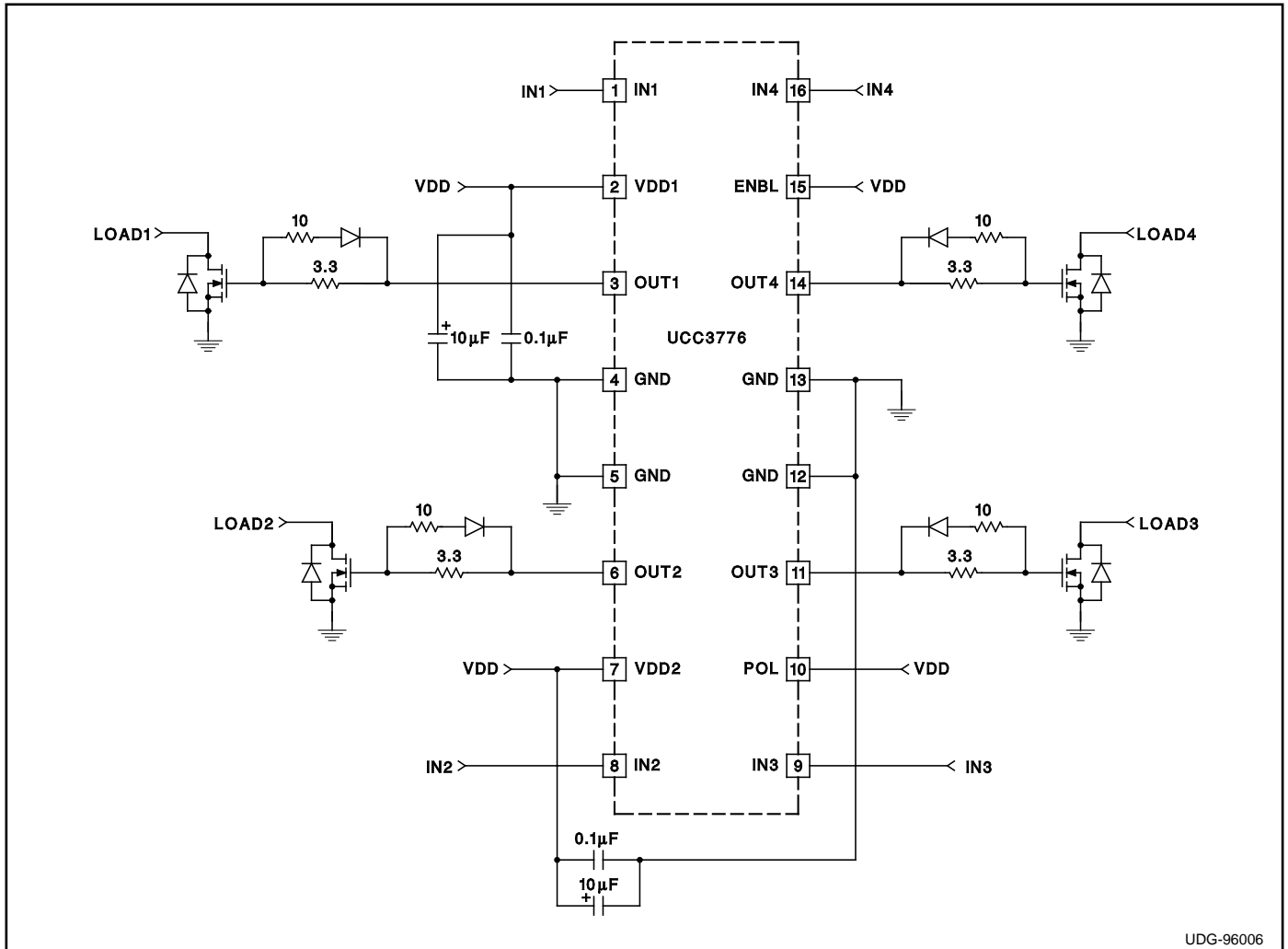

Figure 1. Typical FET Driver Application

**Input Stage**

Each of the four UCC3776 FET driver circuits provides an independent, CMOS compatible input stage. The allowable input voltage range extends from ground to VDD, allowing for easy interface to a wide variety of PWM and power supply support circuitry. The POL and ENBL inputs are tied to all four drivers, and all drivers must be configured as either inverting or noninverting, and all must be either enabled or not enabled.

To prevent oscillations in noisy PWM environments, any unused drivers should have their input stages tied to either VDD or ground. Unlike other CMOS FET drivers, quiescent power current is not significantly affected by the polarity of the driver input signal.

**Output Stage/Gate Driver Considerations**

Many power FET driver data sheets rely solely on rise and fall time specifications into a capacitive load to quan-

tify speed performance. While these specifications are important, they do not provide all the required information. The UCC3776 specifies rise and fall times of 25ns and 10ns respectively into a load of 1nF. This specification can be used to calculate the average slew rate capability of the driver stage over the output voltage range.

However, the gate of a power MOSFET cannot be modeled accurately with a simple capacitor. The voltage/current requirements of the gate vary widely over several distinct phases of FET turn-on and turn-off. The most accurate way to calculate the switching times of power MOSFETs is to determine the total gate charge requirement (Qg), which is usually specified by the MOSFET manufacturer, and determine the peak current capability of the MOSFET gate driver. Ideally the driver's peak current can be delivered while the MOSFET gate is transitioning through its plateau or "Miller" level, when current demands are highest.

## APPLICATION INFORMATION (cont.)

The UCC3776 specifies peak source and sink currents for a driver output voltage of 5V. This output voltage approximately coincides with the average gate plateau voltage of a power MOSFET. Outside of the plateau region the gate drive waveform is primarily limited by the slew rate capability of the driver. Through proper analysis of the MOSFET's gate drive requirements and the specifications for the UCC3776, an accurate model of AC performance can be created. For a detailed description of MOSFET AC gate drive requirements please see Unitrode Application Notes U-118 and U-137. Although the Unitrode power drivers referenced in these application notes are bipolar devices, the information relating to MOSFET gate drive characteristics is applicable.

### Power Supply Decoupling/Grounding

The high peak currents required to charge high capacitance MOSFET gates make proper power supply decoupling and grounding essential. The UCC3776 provides two power supply inputs (VDD1 and VDD2) to allow for optimum internal circuit layout and minimum resistive voltage drop with high peak current loads. VDD1 provides the drive current for outputs 1 and 4, while VDD2 provides drive current for outputs 2 and 3. Both of these pins must be externally connected to the source power supply, and the DC potential difference between these two points should be limited to 100mV. Under no circumstances should an output driver be used with only one supply input connected.

To guarantee a low impedance current path over a wide frequency range, each supply input should be separately bypassed to ground with both a high value tantalum or electrolytic capacitor in parallel with a 0.1μF ceramic capacitor. The exact value of the tantalum or electrolytic capacitor will depend on the charge requirements of the MOSFET gate. For most applications a value between 1μF and 10μF should suffice. Connections for ground leads should be kept as short as possible. The driver chip and support electronics should be located over a large copper ground plane if layout conditions allow it.

### Power Dissipation/Thermal Considerations

Being a CMOS device, the standby power dissipation of the UCC3776 is quite low. For a 15V supply, the maximum quiescent current of 2mA results in a maximum power loss of only 30mW. However, driving high frequency MOSFETs at high peak currents results in additional power dissipation. This is because each time the MOSFET gate is charged or discharged, the energy transfer is only 50% efficient. The same amount of energy that is transferred to the gate is lost in the drive stage.

In order to determine the average output stage loss, the

gate drive energy ( $W_{GD}$ ) is computed as:

$$1) \quad W_{GD} = 2 \cdot 0.5 \cdot C_G \cdot V^2 = \frac{Q_G}{V} \cdot V^2 = Q_G \cdot V$$

Where  $Q_G$  is the MOSFET's total gate charge, and  $V$  is the gate voltage. The factor of two results from the fact that the gate drive circuit must charge and discharge the gate every electrical cycle. Each time the gate is charged or discharged, the gate drive dissipates an amount of energy equal to the energy supplied to the gate. Power lost due to driving the gate is:

$$2) \quad PL_{GD} = \frac{W_{GD}}{T} = \frac{Q \cdot V}{T} = Q_G \cdot V \cdot F$$

Where  $F$  is the operating frequency of the MOSFET. This is a worst case assumption since the power loss is shared by the output driver and the gate resistor. If a relatively large value series gate resistor is used, the power loss in the gate driver is reduced. The penalty for this is slower switching speed, and therefore more loss in the MOSFET. For high power MOSFETs this power loss can be significant.

To illustrate a typical example of driver loss, consider a MOSFET with 70nC of gate charge and a 15V gate voltage. The power loss at 200kHz is:

$$3) \quad PL_{GD} = 70nC \cdot 15V \cdot 200kHz = 210mW$$

This analysis applies to one of the four drivers on the UCC3776. Four drivers operating under the same conditions results in a total power loss of 840mW. At higher frequencies the dissipation will be proportionally greater. This example demonstrates the need for power packaging which is available on the UCC3776, and not available on many other FET drivers.

After device power dissipation has been estimated, proper heat sinking must be provided to ensure that the device junction temperature does not exceed the specified maximum. Refer to the packaging section of the databook for package thermal impedance information.

### Application Circuits

Figure 1 depicts a typical gate drive application circuit. Four independent, noninverting low side FET drivers are shown. Although series gate drive resistors are not required because all FET drivers have a finite peak current capability, it is good practice to include some series resistance to limit peak current and to prevent oscillations due to parasitic inductance and capacitance. The parallel diode and resistor allow for a faster gate turn off than turn on. This characteristic is often desirable for bridge driver applications to prevent MOSFET cross conduction in the power stage.

**APPLICATION INFORMATION (cont.)**

Figure 2 shows an applications circuit with paralleled output drivers. If it is required to drive high gate charge MOSFETs, the UCC3776 output drivers can be combined for higher peak current capability. It is good practice to provide separate gate resistor networks to each individual MOSFET as shown. This will ensure that each driver circuit will not see excessive current during the high gate charge portion of the switching waveform. This practice also tends to isolate driver circuits to reduce the possibility of ringing and crosstalk. If all four drivers are used to drive

a single MOSFET, then four separate gate drive resistor networks should be used.

Figure 3 shows a transformer coupled full bridge power stage. The UCC3776 is ideally suited for interfacing between low power PWM outputs and high power output stages. Although the UC3879 phase shift controller is shown in this example, the UCC3776 can be used in many PWM controller applications where high power FET drivers are required.

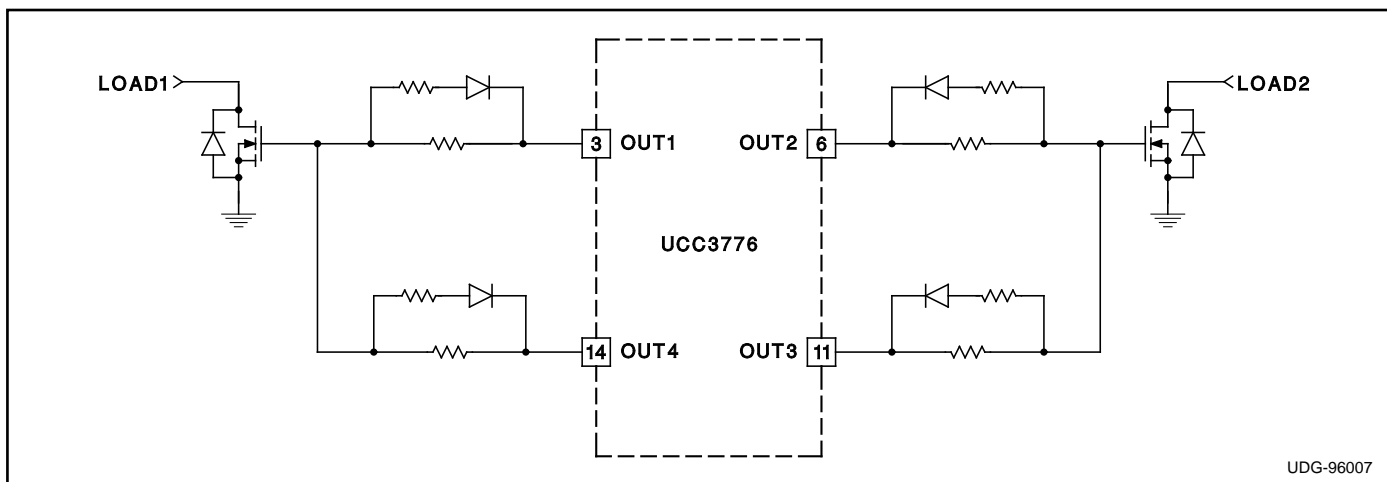

**Figure 2. Parallel Output Drivers**

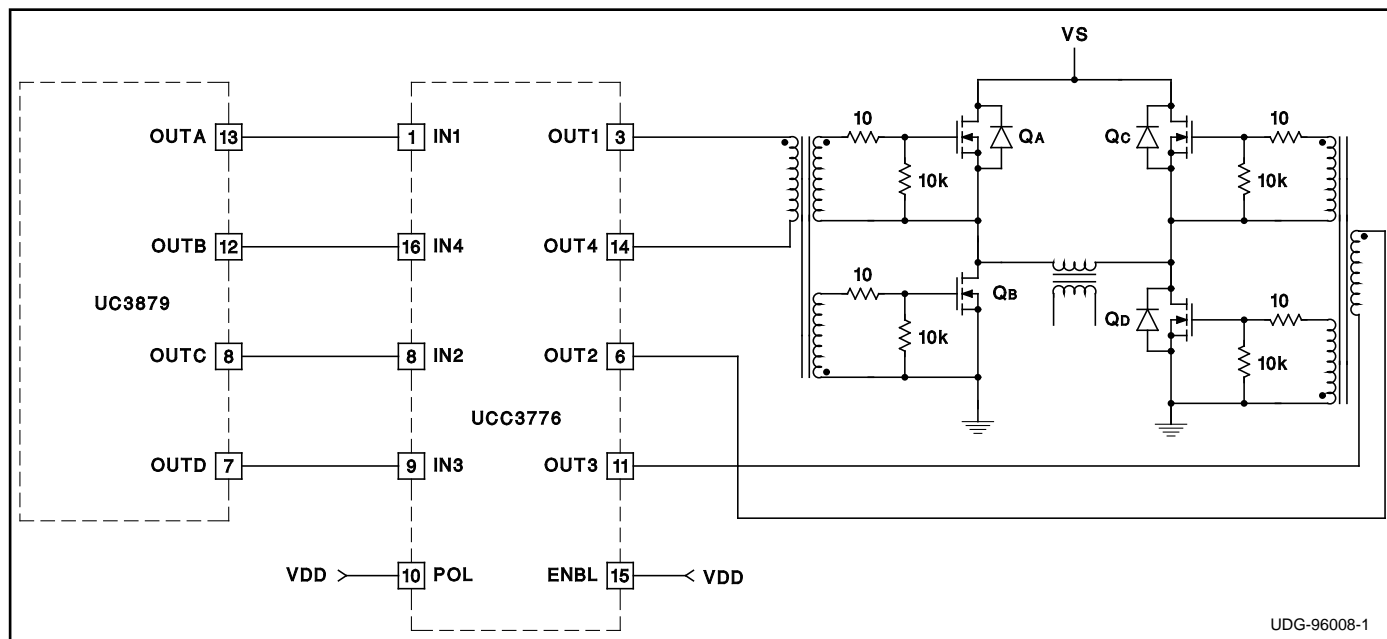

**Figure 3. Full Bridge Driver Application**

**PACKAGING INFORMATION**

Orderable Device	Status <sup>(1)</sup>	Package Type	Package Drawing	Pins	Package Qty	Eco Plan <sup>(2)</sup>	Lead/Ball Finish	MSL Peak Temp <sup>(3)</sup>
UCC2776DP	OBSOLETE	SOIC	D	16		TBD	Call TI	Call TI
UCC2776DPTR	OBSOLETE	SOIC	D	16		TBD	Call TI	Call TI
UCC3776DP	OBSOLETE	SOIC	D	16		TBD	Call TI	Call TI
UCC3776DPTR	OBSOLETE	SOIC	D	16		TBD	Call TI	Call TI
UCC3776N	OBSOLETE	PDIP	N	16		TBD	Call TI	Call TI

<sup>(1)</sup> The marketing status values are defined as follows:

**ACTIVE:** Product device recommended for new designs.

**LIFEBUY:** TI has announced that the device will be discontinued, and a lifetime-buy period is in effect.

**NRND:** Not recommended for new designs. Device is in production to support existing customers, but TI does not recommend using this part in a new design.

**PREVIEW:** Device has been announced but is not in production. Samples may or may not be available.

**OBSOLETE:** TI has discontinued the production of the device.

<sup>(2)</sup> Eco Plan - The planned eco-friendly classification: Pb-Free (RoHS), Pb-Free (RoHS Exempt), or Green (RoHS & no Sb/Br) - please check <http://www.ti.com/productcontent> for the latest availability information and additional product content details.

**TBD:** The Pb-Free/Green conversion plan has not been defined.

**Pb-Free (RoHS):** TI's terms "Lead-Free" or "Pb-Free" mean semiconductor products that are compatible with the current RoHS requirements for all 6 substances, including the requirement that lead not exceed 0.1% by weight in homogeneous materials. Where designed to be soldered at high temperatures, TI Pb-Free products are suitable for use in specified lead-free processes.

**Pb-Free (RoHS Exempt):** This component has a RoHS exemption for either 1) lead-based flip-chip solder bumps used between the die and package, or 2) lead-based die adhesive used between the die and leadframe. The component is otherwise considered Pb-Free (RoHS compatible) as defined above.

**Green (RoHS & no Sb/Br):** TI defines "Green" to mean Pb-Free (RoHS compatible), and free of Bromine (Br) and Antimony (Sb) based flame retardants (Br or Sb do not exceed 0.1% by weight in homogeneous material)

<sup>(3)</sup> MSL, Peak Temp. -- The Moisture Sensitivity Level rating according to the JEDEC industry standard classifications, and peak solder temperature.

**Important Information and Disclaimer:**The information provided on this page represents TI's knowledge and belief as of the date that it is provided. TI bases its knowledge and belief on information provided by third parties, and makes no representation or warranty as to the accuracy of such information. Efforts are underway to better integrate information from third parties. TI has taken and continues to take reasonable steps to provide representative and accurate information but may not have conducted destructive testing or chemical analysis on incoming materials and chemicals. TI and TI suppliers consider certain information to be proprietary, and thus CAS numbers and other limited information may not be available for release.

In no event shall TI's liability arising out of such information exceed the total purchase price of the TI part(s) at issue in this document sold by TI to Customer on an annual basis.

## IMPORTANT NOTICE

Texas Instruments Incorporated and its subsidiaries (TI) reserve the right to make corrections, modifications, enhancements, improvements, and other changes to its products and services at any time and to discontinue any product or service without notice. Customers should obtain the latest relevant information before placing orders and should verify that such information is current and complete. All products are sold subject to TI's terms and conditions of sale supplied at the time of order acknowledgment.

TI warrants performance of its hardware products to the specifications applicable at the time of sale in accordance with TI's standard warranty. Testing and other quality control techniques are used to the extent TI deems necessary to support this warranty. Except where mandated by government requirements, testing of all parameters of each product is not necessarily performed.

TI assumes no liability for applications assistance or customer product design. Customers are responsible for their products and applications using TI components. To minimize the risks associated with customer products and applications, customers should provide adequate design and operating safeguards.

TI does not warrant or represent that any license, either express or implied, is granted under any TI patent right, copyright, mask work right, or other TI intellectual property right relating to any combination, machine, or process in which TI products or services are used. Information published by TI regarding third-party products or services does not constitute a license from TI to use such products or services or a warranty or endorsement thereof. Use of such information may require a license from a third party under the patents or other intellectual property of the third party, or a license from TI under the patents or other intellectual property of TI.

Reproduction of TI information in TI data books or data sheets is permissible only if reproduction is without alteration and is accompanied by all associated warranties, conditions, limitations, and notices. Reproduction of this information with alteration is an unfair and deceptive business practice. TI is not responsible or liable for such altered documentation. Information of third parties may be subject to additional restrictions.

Resale of TI products or services with statements different from or beyond the parameters stated by TI for that product or service voids all express and any implied warranties for the associated TI product or service and is an unfair and deceptive business practice. TI is not responsible or liable for any such statements.

TI products are not authorized for use in safety-critical applications (such as life support) where a failure of the TI product would reasonably be expected to cause severe personal injury or death, unless officers of the parties have executed an agreement specifically governing such use. Buyers represent that they have all necessary expertise in the safety and regulatory ramifications of their applications, and acknowledge and agree that they are solely responsible for all legal, regulatory and safety-related requirements concerning their products and any use of TI products in such safety-critical applications, notwithstanding any applications-related information or support that may be provided by TI. Further, Buyers must fully indemnify TI and its representatives against any damages arising out of the use of TI products in such safety-critical applications.

TI products are neither designed nor intended for use in military/aerospace applications or environments unless the TI products are specifically designated by TI as military-grade or "enhanced plastic." Only products designated by TI as military-grade meet military specifications. Buyers acknowledge and agree that any such use of TI products which TI has not designated as military-grade is solely at the Buyer's risk, and that they are solely responsible for compliance with all legal and regulatory requirements in connection with such use.

TI products are neither designed nor intended for use in automotive applications or environments unless the specific TI products are designated by TI as compliant with ISO/TS 16949 requirements. Buyers acknowledge and agree that, if they use any non-designated products in automotive applications, TI will not be responsible for any failure to meet such requirements.

Following are URLs where you can obtain information on other Texas Instruments products and application solutions:

### Products

Amplifiers	<a href="http://amplifier.ti.com">amplifier.ti.com</a>
Data Converters	<a href="http://dataconverter.ti.com">dataconverter.ti.com</a>
DSP	<a href="http://dsp.ti.com">dsp.ti.com</a>
Clocks and Timers	<a href="http://www.ti.com/clocks">www.ti.com/clocks</a>
Interface	<a href="http://interface.ti.com">interface.ti.com</a>
Logic	<a href="http://logic.ti.com">logic.ti.com</a>
Power Mgmt	<a href="http://power.ti.com">power.ti.com</a>
Microcontrollers	<a href="http://microcontroller.ti.com">microcontroller.ti.com</a>
RFID	<a href="http://www.ti-rfid.com">www.ti-rfid.com</a>
RF/IF and ZigBee® Solutions	<a href="http://www.ti.com/lprf">www.ti.com/lprf</a>

### Applications

Audio	<a href="http://www.ti.com/audio">www.ti.com/audio</a>
Automotive	<a href="http://www.ti.com/automotive">www.ti.com/automotive</a>
Broadband	<a href="http://www.ti.com/broadband">www.ti.com/broadband</a>
Digital Control	<a href="http://www.ti.com/digitalcontrol">www.ti.com/digitalcontrol</a>
Medical	<a href="http://www.ti.com/medical">www.ti.com/medical</a>
Military	<a href="http://www.ti.com/military">www.ti.com/military</a>
Optical Networking	<a href="http://www.ti.com/opticalnetwork">www.ti.com/opticalnetwork</a>
Security	<a href="http://www.ti.com/security">www.ti.com/security</a>
Telephony	<a href="http://www.ti.com/telephony">www.ti.com/telephony</a>
Video & Imaging	<a href="http://www.ti.com/video">www.ti.com/video</a>
Wireless	<a href="http://www.ti.com/wireless">www.ti.com/wireless</a>

Mailing Address: Texas Instruments, Post Office Box 655303, Dallas, Texas 75265  
Copyright © 2008, Texas Instruments Incorporated