

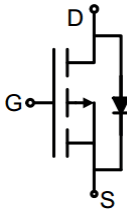
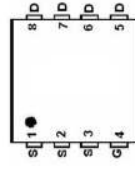

## P-Channel Enhancement Mode Power MOSFET

<p><b>Description</b></p> <p>The G26P04D5 uses advanced trench technology to provide excellent <math>R_{DS(ON)}</math>, low gate charge. It can be used in a wide variety of applications.</p> <p><b>General Features</b></p> <ul style="list-style-type: none"> <li>● <math>V_{DS}</math> -40 V</li> <li>● <math>I_D</math> (at <math>V_{GS} = -10V</math>) -26A</li> <li>● <math>R_{DS(ON)}</math> (at <math>V_{GS} = -10V</math>) &lt; 18m<math>\Omega</math></li> <li>● <math>R_{DS(ON)}</math> (at <math>V_{GS} = -4.5V</math>) &lt; 22m<math>\Omega</math></li> <li>● 100% Avalanche Tested</li> <li>● RoHS Compliant</li> </ul> <p><b>Application</b></p> <ul style="list-style-type: none"> <li>● Power switch</li> <li>● DC/DC converters</li> </ul>		 <p>Schematic diagram</p>  <p>Marking and pin assignment</p>  <p>DFN5*6-8L</p>	
<b>Device</b>	<b>Package</b>	<b>Marking</b>	<b>Packaging</b>
G26P04D5	DFN5*6-8L	G26P04	5000pcs/Reel

### Absolute Maximum Ratings $T_C = 25^{\circ}C$ , unless otherwise noted

Parameter	Symbol	Value	Unit
Drain-Source Voltage	$V_{DS}$	-40	V
Continuous Drain Current	$I_D$	-26	A
Pulsed Drain Current (note1)	$I_{DM}$	-91	A
Gate-Source Voltage	$V_{GS}$	$\pm 20$	V
Power Dissipation	$P_D$	50	W
Operating Junction and Storage Temperature Range	$T_J, T_{stg}$	-55 To 150	$^{\circ}C$

### Thermal Resistance

Parameter	Symbol	Value	Unit
Thermal Resistance, Junction-to-Ambient	$R_{thJA}$	50	$^{\circ}C/W$
Thermal Resistance, Junction-to-Case	$R_{thJC}$	2.5	$^{\circ}C/W$

Specifications $T_J = 25^\circ\text{C}$ , unless otherwise noted						
Parameter	Symbol	Test Conditions	Value			Unit
			Min.	Typ.	Max.	
<b>Static Parameters</b>						
Drain-Source Breakdown Voltage	$V_{(BR)DSS}$	$V_{GS} = 0V, I_D = -250\mu\text{A}$	-40	--	--	V
Zero Gate Voltage Drain Current	$I_{DSS}$	$V_{DS} = -40V, V_{GS} = 0V$	--	--	-1	$\mu\text{A}$
Gate-Source Leakage	$I_{GSS}$	$V_{GS} = \pm 20V$	--	--	$\pm 100$	nA
Gate-Source Threshold Voltage	$V_{GS(th)}$	$V_{DS} = V_{GS}, I_D = -250\mu\text{A}$	-1	-1.5	-2.5	V
Drain-Source On-Resistance	$R_{DS(on)}$	$V_{GS} = -10V, I_D = -12A$	--	15	18	m $\Omega$
		$V_{GS} = -4.5V, I_D = -12A$	--	18	22	
Forward Transconductance	$g_{FS}$	$V_{DS} = -5V, I_D = -12A$	--	28	--	S
<b>Dynamic Parameters</b>						
Input Capacitance	$C_{iss}$	$V_{GS} = 0V,$ $V_{DS} = -20V,$ $f = 1.0\text{MHz}$	--	2479	--	pF
Output Capacitance	$C_{oss}$		--	274	--	
Reverse Transfer Capacitance	$C_{rss}$		--	204	--	
Total Gate Charge	$Q_g$	$V_{DD} = -40V,$ $I_D = -12A,$ $V_{GS} = -10V$	--	45	--	nC
Gate-Source Charge	$Q_{gs}$		--	6.1	--	
Gate-Drain Charge	$Q_{gd}$		--	10.1	--	
Turn-on Delay Time	$t_{d(on)}$	$V_{DS} = -20V,$ $I_D = -1A,$ $R_G = 6\Omega$	--	9	--	ns
Turn-on Rise Time	$t_r$		--	7	--	
Turn-off Delay Time	$t_{d(off)}$		--	78	--	
Turn-off Fall Time	$t_f$		--	39	--	
<b>Drain-Source Body Diode Characteristics</b>						
Continuous Body Diode Current	$I_S$	$T_C = 25^\circ\text{C}$	--	--	-26	A
Body Diode Voltage	$V_{SD}$	$T_J = 25^\circ\text{C}, I_F = I_S, V_{GS} = 0V$	--	--	-1.2	V

**Notes**

1. Repetitive Rating: Pulse width limited by maximum junction temperature
2. Identical low side and high side switch with identical  $R_G$

Gate Charge Test Circuit

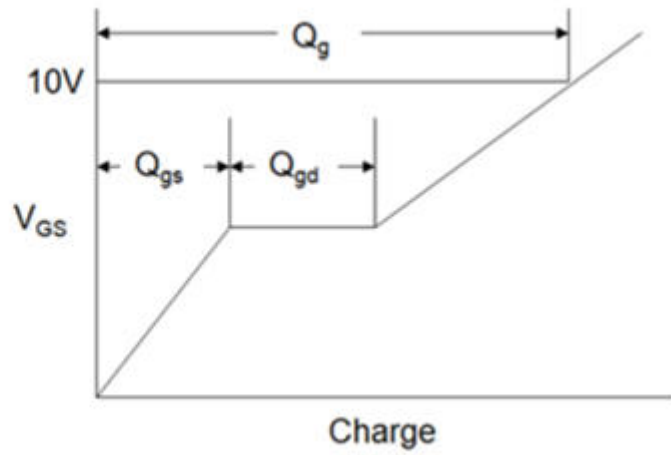
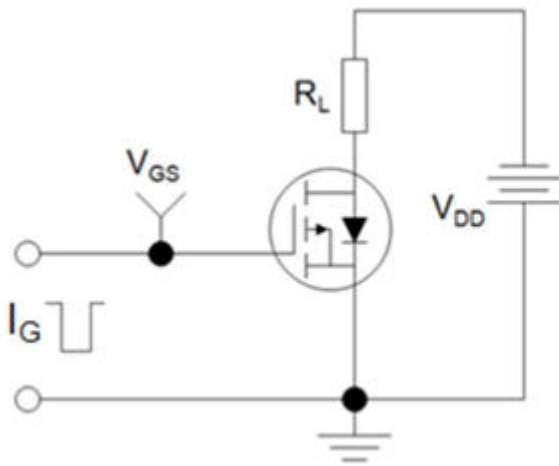

Switch Time Test Circuit

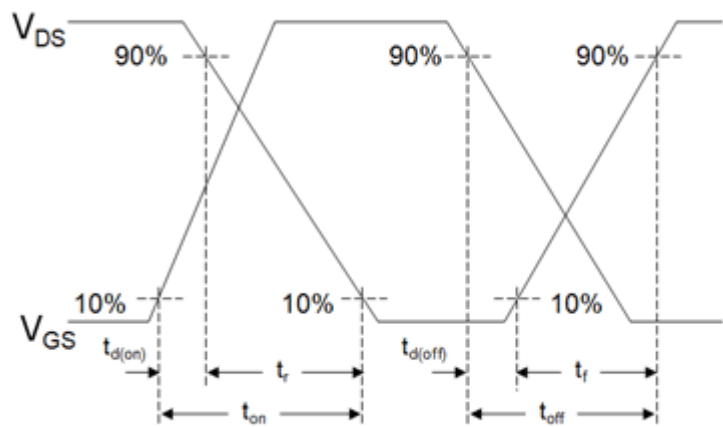
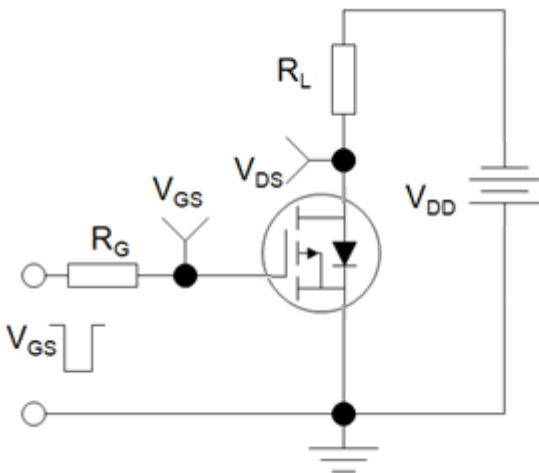

EAS Test Circuit

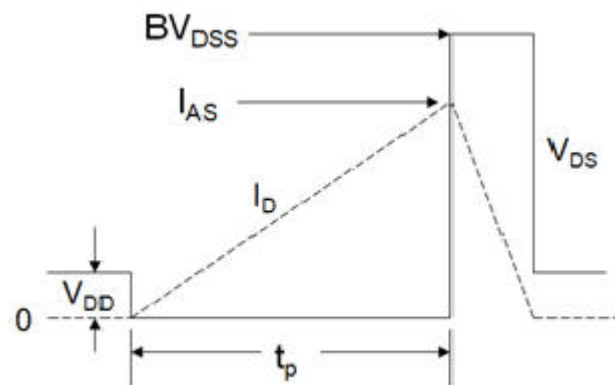
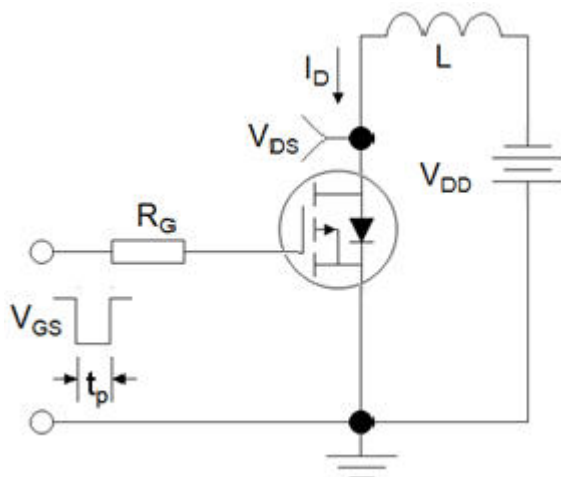

Typical Characteristics  $T_J = 25^\circ\text{C}$ , unless otherwise noted

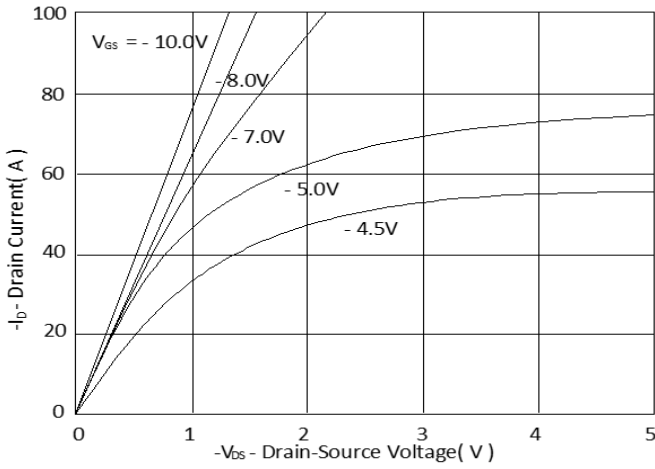

Fig.1 Typical Output Characteristics

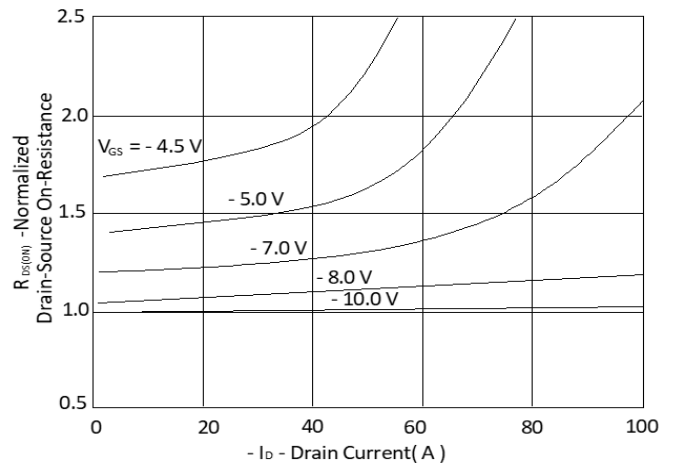

Fig.2 On-Resistance Variation with Drain Current and Gate Voltage

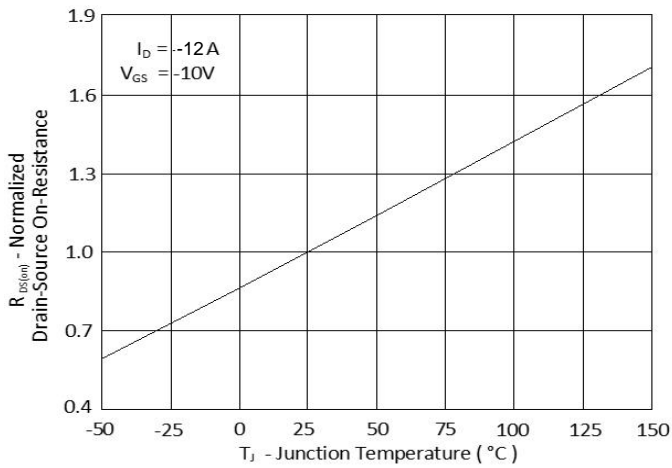

Fig.3 Normalized On-Resistance v.s. Junction Temperature

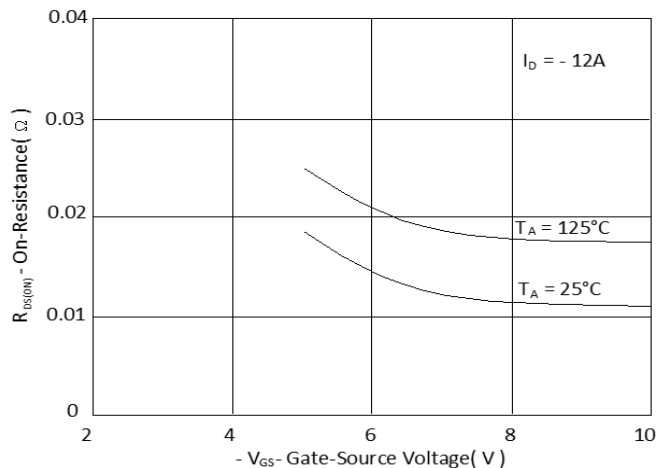

Fig.4 On-Resistance v.s. Gate Voltage

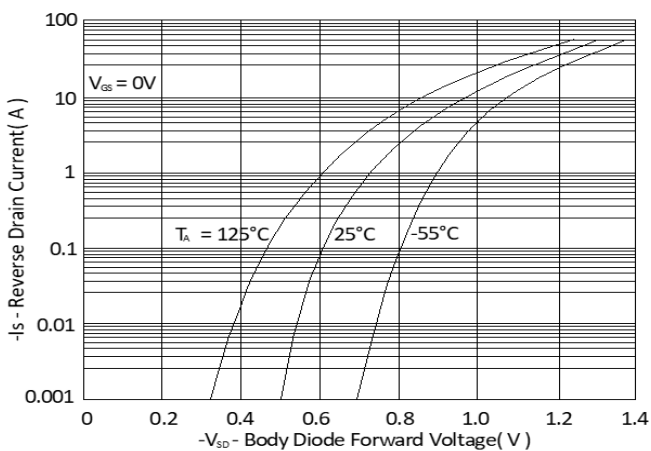

Fig.5 Forward Characteristic of Reverse Diode

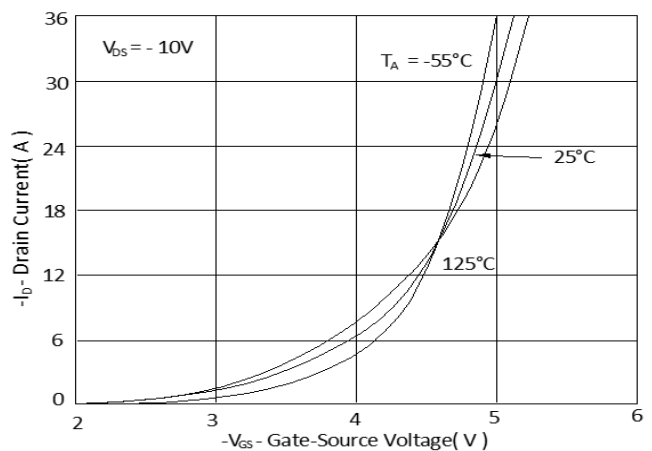

Fig.6 Transfer Characteristics

Typical Characteristics  $T_J = 25^\circ\text{C}$ , unless otherwise noted

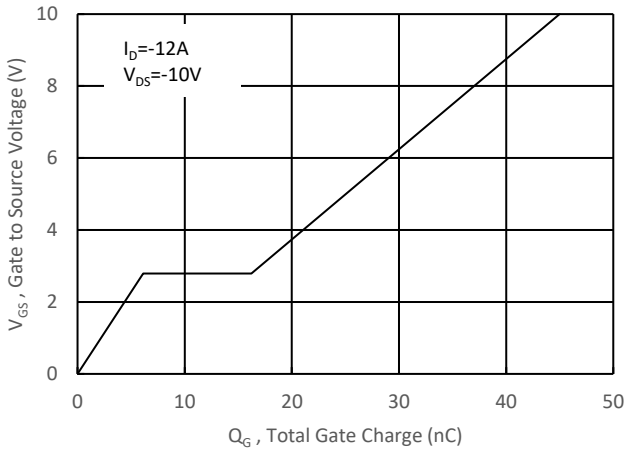

Fig.7 Gate Charge Characteristics

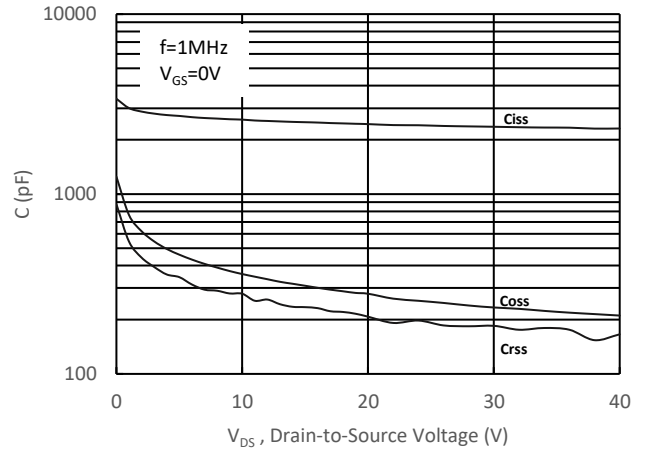

Fig.8 Typical Capacitance Characteristics

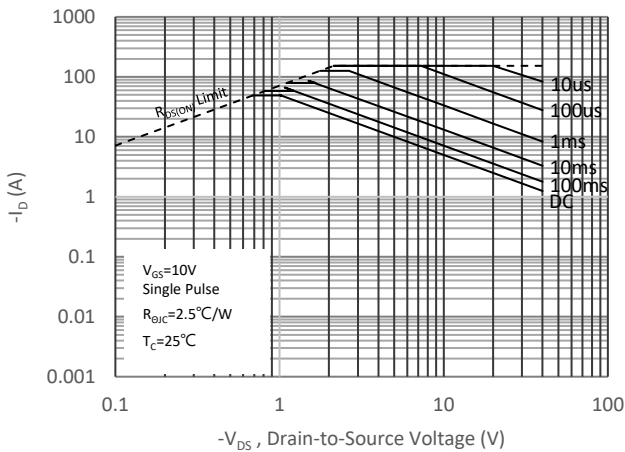

Fig 9. Maximum Safe Operating Area

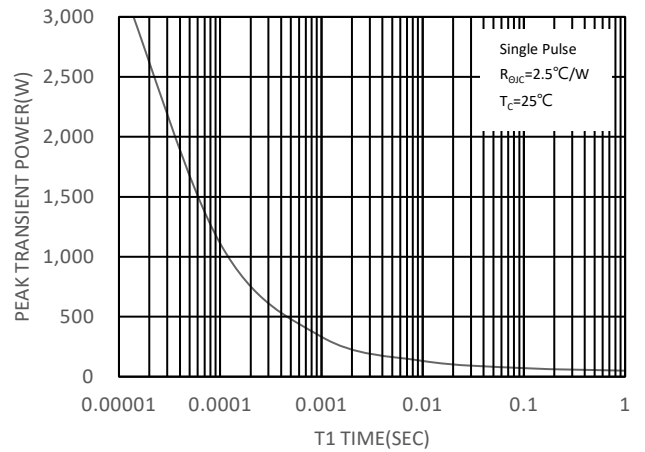

Fig 10. Single Pulse Maximum Power Dissipation

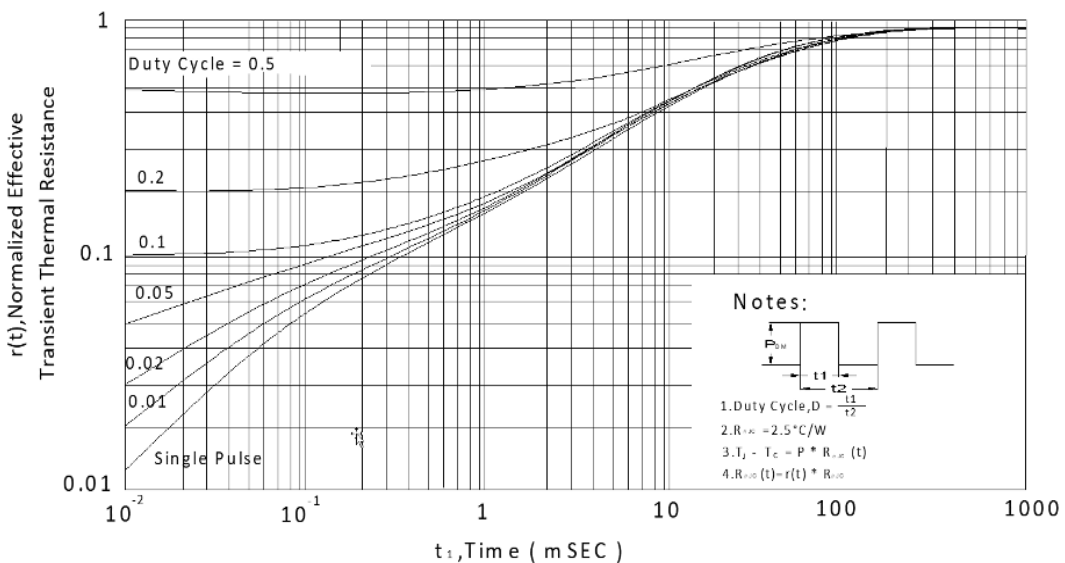
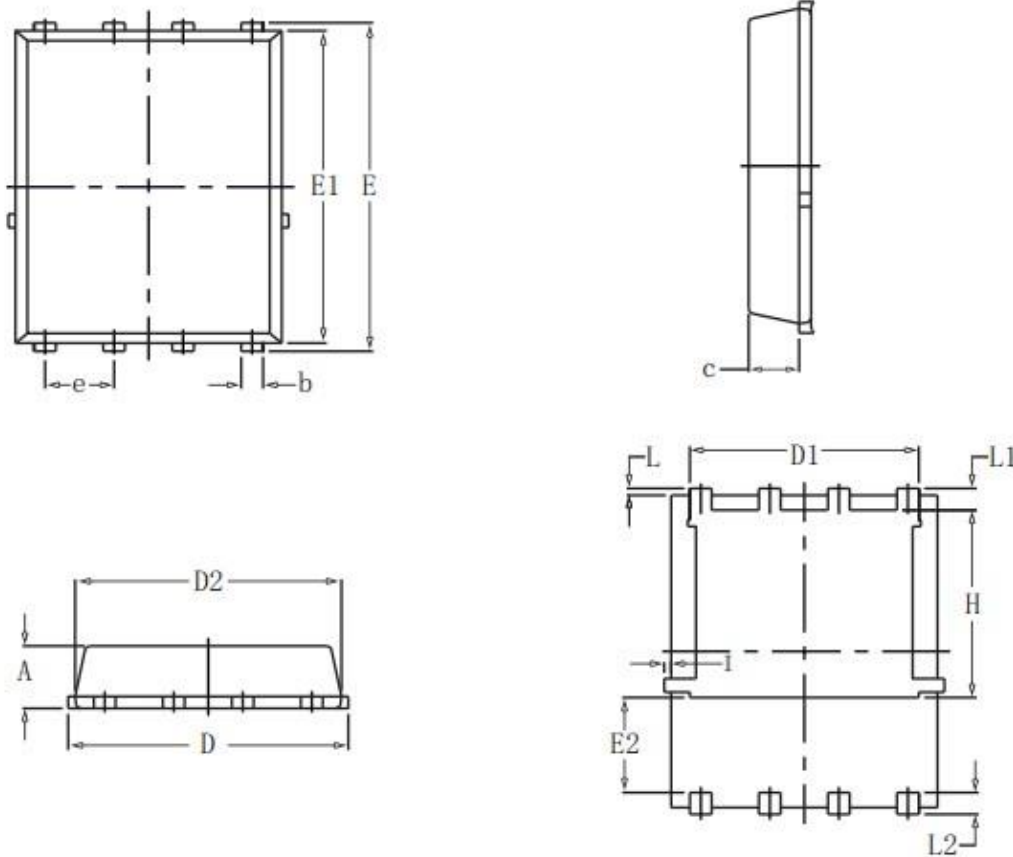

Fig 11. Effective Transient Thermal Impedance

DFN5\*6-8L Package Information



SYMBOL	COMMON			
	MM		INCH	
	MIN	MAX	MIN	MAX
A	1.03	1.17	0.0406	0.0461
b	0.34	0.48	0.0134	0.0189
c	0.824	0.970	0.0324	0.0382
D	4.80	5.40	0.1890	0.2126
D1	4.11	4.31	0.1618	0.1697
D2	4.80	5.00	0.1890	0.1969
E	5.59	6.15	0.2343	0.2421
E1	5.65	5.85	0.2224	0.2303
E2	1.60	-	0.0630	-
e	1.27 BSC		0.05 BSC	
L	0.05	0.25	0.0020	0.0098
L1	0.38	0.50	0.0150	0.0197
L2	0.38	0.50	0.0150	0.0197
H	3.30	3.50	0.1299	0.1378
I	-	0.18	-	0.0070