

# 3DC11LP

## SMD 3D Coil Low profile

13x11.6x3.20mm MAX (2.38mH - 7.2mH)

3-AXIS TRANSPONDER INDUCTOR (3DCOILS™)



### APPLICATIONS

- › Automotive Passive keyless entry systems.
- › Automotive RTPMS with wake up functions.
- › Industrial logistics and control.
- › Access control.
- › Tracking devices.

## 01 CHARACTERISTICS

- › Offers 3 coils, oriented in the 3 space axes, assembled in a single component with full functionality.
- › Suitable for automotive applications (Keyless Entry Systems, RTPMS), etc.
- › Very good electrical performance in the smallest dimensions.
- › High stability in temperature (-40°C to +85°C).
- › High sensitivity values.
- › The inductivity in each axis can be customized to achieve customer requirements.
- › Designs at lower frequencies, 20 kHz or 40 kHz, show a very good electrical performance as well.

## 02 SPECIFICATIONS

### DIMENSIONS AND RECOMMENDED PAD-LAYOUT (mm)

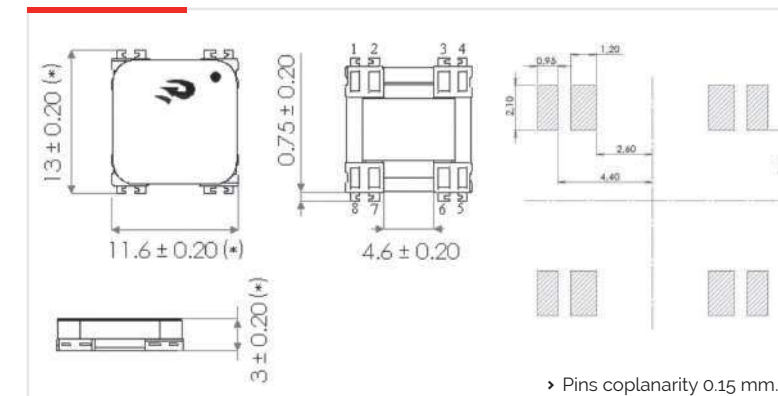

### ELECTRICAL DIAGRAM

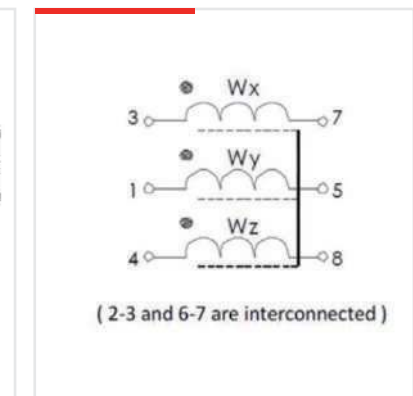

### ELECTRICAL SPECIFICATIONS

P/N	L x,y,z (mH)	Qx,y,z Min	Freq (KHz)	Cres (pF)	SRFx,y (kHz) Min	SRFz (kHz) Min	DCRx,y (Ohm) Max	DCRy,y (Ohm) Max	Sensitivity x,y,z (mV/ App/m) Min	Length (mm)	Width (mm)	Height (mm)
3DC11LP-0238J	2.38	18	125	680	450	900	60,5	82,5	40	13	11,6	3,15
3DC11LP-0247J	2.47	17	125	656	450	900	68	82,5	40	13	11,6	3,15
3DC11LP-0345J	3.45	15	125	470	350	800	100	121	55	13	11,6	3,15
3DC11LP-0405J	4.05	15	125	400	300	600	100	138	60	13	11,6	3,15
3DC11LP-0477J	4.77	15	125	340	320	600	100	150	70	13	11,6	3,15
3DC11LP-0491J	4.91	18	125	330	300	600	100	160	70	13	11,6	3,15
3DC11LP-0720J	7.20	15	125	225	250	500	165	209	85	13	11,6	3,15
3DC11LP-A-2000J	20	5	20	3166	120	350	495	385	22	13	11,6	3,15

This chart is a reference guide for the most common required values at working frequency of 125 kHz. Any other inductance value at LF or tighter tolerances can be provided. Also can be supplied different inductance values in the different winding axis. Please contact our sales department for any inquiry.  
L and Q factor measured at 125 kHz, 1 Vac.  
Sensitivity measured with Helmholtz coils H=8.36 App/m @125 kHz. Contact us for measurement specification.  
SRF: Self Resonant Frequency of the coil.